

Traffa

**MELFA - COBOT ASSISTA
RV-5 AS-D Standard - Handbuch**

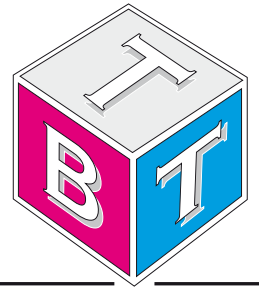

Technisches **B**üro **T**raffa



**WIRKLICH INDUSTRIELL
WIRKLICH KOOPERATIV**

MELFA

as*s*ista

Innovative Roboterlösungen

Der optimale Roboter für Ihre individuelle Anforderung



Mitsubishi Electric Industrial Robot

CR800-05VD Controller

RV-5AS-D Standard Specifications Manual

Safety Precautions

Always read the following precautions and the separate "Collaborative Robot Safety Manual" before starting use of the robot to learn the required measures to be taken.

■ Basic precautions and important points when using collaborative robots

Collaborative robots have a variety of safety functions, so unlike conventional industrial robots, they can work in the same space as humans without being separated by a machine guard.

Even though collaborative robots are equipped with safety functions, it does not guarantee that they will not cause injury. To prevent injury, customers who use robots, machine manufacturers who construct robot systems, and system builders such as system integrators must select and use functions correctly. Peripherals must be designed, manufactured, set, programmed, maintained, and inspected appropriately. Before working with collaborative robots, conduct risk assessments, check that no risk is present, and ensure all required documentation is in order.

It is vitally important that all the points mentioned above are fully understood in order to work with collaborative robots safely and without incident. When using collaborative robots, always keep in mind that they may move unexpectedly.

Revision history

Date of print	Specifications No.	Details of revisions
2020-04-10	BFP-A3727	<ul style="list-style-type: none"> • First print.
2020-07-30	BFP-A3727-A	<ul style="list-style-type: none"> • Revised the battery name.
2020-10-09	BFP-A3727-B	<ul style="list-style-type: none"> • Revised the weight of recommended hands. • Added detailed information to the specifications of the earth leakage breaker.
2021-01-22	BFP-A3727-C	<ul style="list-style-type: none"> • Added an example of a protective circuit. (Fig. 3-8) • Corrected other mistakes and changed some sections. • Added "6.4 EMC installation guideline".
2021-01-29	BFP-A3727-D	<ul style="list-style-type: none"> • Updated contents for the optional product "MELFA-3D Vision 3.0 (3F-53U-WINM)". • Deleted the optional product "MELFA-3D Vision 2.0 (4F-3DVS2-PKG3)" and associated parts.
2021-09-30	BFP-A3727-E	<ul style="list-style-type: none"> • Corrected the explanation of the parameter "SRVON". • Added illustrations showing the installation position of ferrite cores. (Fig. 3-9) • Revised "(5) Parallel I/O interface". • Corrected the explanation of noise in "6.2 Working environment". • Revised "(4) Vision sensor mounting bracket". • Corrected other mistakes and changed some sections.
2022-01-31	BFP-A3727-F	<ul style="list-style-type: none"> • Revised "6.4 EMC installation guideline".
2022-06-30	BFP-A3727-G	<ul style="list-style-type: none"> • Corrected the model name of the EtherCAT module manufactured by HMS. • Corrected errors in writing of the GR connector section in "(2) Solenoid valve set".

■ Introduction

This is a vertical, multi-joint robot intended to be used for collaborative operation with humans. However, to comply with the target application, a work system having a well-balanced robot arm, peripheral devices or robot and hand section must be structured.

When creating these standard specifications, we have edited them so that the Mitsubishi robot's characteristics and specifications can be easily understood by users considering the implementation of robots. However, if there are any unclear points, please contact your nearest Mitsubishi branch or dealer.

Mitsubishi hopes that you will consider these standard specifications and use our robots.

Note that in this specification document the specifications related to the robot arm is described [Page 12, "2 Robot arm"](#), the specifications related to the controller [Page 42, "3 Controller"](#), and software functions and a command list [Page 94, "4 Software"](#) separately.

This document has indicated the specification of the following types robot.

<Robot type>

- RV-5AS-D

- No part of this manual may be reproduced by any means or in any form, without prior consent from Mitsubishi.
- The contents of this manual are subject to change without notice.
- The specifications values are based on Mitsubishi standard testing methods.
- The information contained in this document has been written to be accurate as much as possible. Please interpret that items not described in this document "cannot be performed." or "alarm may occur". Please contact your nearest dealer if you find any doubtful, wrong or skipped point.
- This is the original document.
- Microsoft, Windows, Windows 7, Windows 8, Windows 8.1, Windows 10 are either registered trademarks or trademarks of Microsoft Corporation in the United States and/or other countries.
- The official name of Windows® is Microsoft®Windows®Operating System.
- Windows® 7, Windows® 8, Windows® 8.1, Windows® 10 are either product names of Microsoft Corporation in the United States.
- Ethernet is registered trademarks or trademarks of Xerox Corporation in the United States.
- All other company names and production names in this document are the trademarks or registered trademarks of their respective owners.
- Referenced Standard (Requirement of Chinese standardized law): This Product is designed and manufactured accordance with GB 11291.1.
- Illustrations in this Instruction Manual may differ from the actual products.

Contents

	Page
1 General configuration	1-1
1.1 Structural equipment	1-1
1.1.1 Standard structural equipment	1-1
1.1.2 Options	1-1
1.1.3 Maintenance parts	1-1
1.2 Model type name of robot	1-2
1.2.1 How to identify the robot model	1-2
1.3 Contents of the structural equipment	1-3
1.3.1 Robot arm	1-3
1.3.2 Controller	1-4
1.3.3 Function extension device	1-5
1.3.4 Minimum equipment required to operate the robot	1-6
1.4 Contents of the Option equipment	1-8
1.4.1 List of the robot arm option equipment	1-8
1.4.2 List of the controller option equipment and special specification	1-8
1.4.3 Function extension device	1-9
1.4.4 Recommended vision sensors	1-9
1.4.5 Recommended hands	1-10
2 Robot arm	2-12
2.1 Standard specifications	2-12
2.1.1 Basic specifications	2-12
2.1.2 The counter-force applied to the installation surface	2-13
2.2 Definition of specifications	2-14
2.2.1 Pose repeatability	2-14
2.2.2 Rated load (mass capacity)	2-15
2.2.3 Relationships Among Mass Capacity, Speed, and Acceleration/Deceleration Speed	2-16
(1) Setting hand and workpiece conditions	2-16
2.2.4 Vibrations at the Tip of the Arm during Low-Speed Operation of the Robot	2-16
2.2.5 Collision detection	2-17
2.2.6 Protection specifications	2-17
(1) Types of protection specifications	2-17
(2) About the use with the bad environment	2-18
2.3 Names of each part of the robot	2-19
2.3.1 Operation buttons	2-20
2.3.2 Status indicator LED	2-21
2.4 Outside dimension • Operating range diagram	2-23
2.4.1 Outside dimensions of machine cables	2-26
2.5 Tooling	2-27
2.5.1 Wiring and piping for hand	2-27
2.5.2 Internal wiring and piping	2-29
(1) Internal pneumatic plumbing	2-29
(2) Internal wiring of the hand I/O cables	2-29
(3) Ethernet cable and force sensor wiring	2-29
2.5.3 Wiring and piping system diagram for hand	2-30
2.5.4 Electrical specifications of hand input/output	2-31
2.5.5 Air supply circuit example for the hand	2-32
2.5.6 About the Installation of Tooling Wiring and Piping	2-32
2.6 Options	2-33
(1) Machine cable (replacement)	2-34
(2) Solenoid valve set	2-35
(3) 2-piece force sensor conversion cable set	2-37
(4) Vision sensor mounting bracket	2-38
2.7 About Overhaul	2-40
2.8 Maintenance parts	2-41

Contents

	Page
3 Controller	3-42
3.1 Standard specifications	3-42
3.1.1 Basic specifications	3-42
(1) CR800-05VD controller	3-42
(2) Safety extension unit	3-44
3.1.2 Protection specifications and operating supply	3-46
(1) Protection specifications	3-46
(2) Operating supply	3-46
3.2 Names of each part	3-47
3.2.1 CR800-05VD controller	3-47
3.2.2 Safety extension unit	3-49
3.3 Outside dimensions/Installation dimensions	3-50
3.3.1 Outside dimensions	3-50
(1) CR800-05VD controller	3-50
(2) Safety extension unit	3-53
3.3.2 Installation dimensions	3-54
3.4 External input/output	3-56
3.4.1 Types	3-56
3.5 Dedicated input/output	3-57
3.6 Emergency stop input and output etc.	3-60
3.6.1 Connection of the external emergency stop and mode selector switch	3-61
3.6.2 Special stop input (SKIP)	3-65
3.6.3 Door switch function	3-66
3.6.4 Mode selector switch function	3-66
(1) Automatic Operation/Jog Operation/Brake Release and Necessary Switch Settings	3-67
3.7 Options	3-69
(1) Teaching pendant (T/B)	3-70
(2) High efficient teaching pendant (T/B)	3-73
(3) MELSOFT RT ToolBox3/MELSOFT RT ToolBox3 mini	3-75
(4) MELSOFT RT VisualBox	3-77
(5) Parallel I/O interface	3-79
(6) External I/O cable	3-85
(7) CC-Link interface	3-87
(8) SD memory card	3-90
(9) Easy-setup kit	3-91
3.8 Maintenance parts	3-93
4 Software	4-94
4.1 List of commands	4-94
5 Instruction Manual	5-95
5.1 The details of each instruction manuals	5-95
6 Safety	6-96
6.1 Safety	6-96
6.1.1 Self-diagnosis stop functions	6-96
6.1.2 External I/O signals that can be used for preventative safety measures	6-97
6.1.3 Examples of safety measures	6-98
(1) External emergency stop connection [supplementary explanation]	6-105
6.2 Working environment	6-106
(1) Power supply	6-106
(2) Noise	6-106
(3) Temperature and humidity	6-106
(4) Vibration	6-106
(5) Installation environment	6-106
6.3 Precautions for handling	6-106

Contents

	Page
6.4 EMC installation guideline	6-108
6.4.1 Outlines	6-108
6.4.2 EMC	6-108
6.4.3 EMC measures	6-108
6.4.4 Example of EMC measures	6-109
6.4.5 Parts for EMC measures	6-109
7 Appendix	Appendix-110
Appendix 1: Inertia calculation method	Appendix-110
(1) Load moment calculation example (for J5 axis with flange facing downwards)	Appendix-110
(2) Load inertia calculation example (for J6 axis)	Appendix-110
Appendix 2: Classification of external I/O functions	Appendix-111
Appendix 3: Safety diagnosis function (test pulse diagnosis)	Appendix-112
Appendix 4: Safety block diagram	Appendix-113
Appendix 5: Connections of recommended hands, recommended vision sensors and the force sensor	
Appendix-114	
(1) Hand: Co-act EGP-C40 N-N-Assista (Manufactured by SCHUNK)	Appendix-114
(2) Hand: HRC-03-099455 (Manufactured by Zimmer Group)	Appendix-119
(3) Hand: KIT-ASSISTA-G (Manufactured by GIMATIC)	Appendix-123
(4) Hand: ROB-SET ECBPM ASSISTA (Manufactured by SCHMALZ)	Appendix-128
Appendix 6: Declaration of Conformity	Appendix-132
Appendix 7: Specifications discussion material	Appendix-134

1 General configuration

1.1 Structural equipment

Structural equipment consists of the following types.

1.1.1 Standard structural equipment

The following items are enclosed as a standard.

- 1) Robot arm
- 2) Controller
- 3) Machine cable
- 4) Safety extension unit
- 5) Robot arm installation bolts
- 6) CD-ROM (Instruction manual)

1.1.2 Options

User can install options after their delivery. The customer needs to arrange for the installation.

1.1.3 Maintenance parts

Materials and parts for the maintenance use.

1.2 Model type name of robot

This robot has arranged the type name corresponding to load mass, arm length, and environment specification.

1.2.1 How to identify the robot model

RV - \diamond AS - D
(a) (b) (c) (d)

- (a) RV Indicates the vertical multi-joint robot.
- (b) \diamond Indicates the rated load capacity.
5 : 5kg
- (c) AS Indicates the robot is part of the "ASSISTA" series.
- (d) D Indicates the controller type.
D : Stand alone type

1.3 Contents of the structural equipment

1.3.1 Robot arm

The list of structural equipment is shown in below.

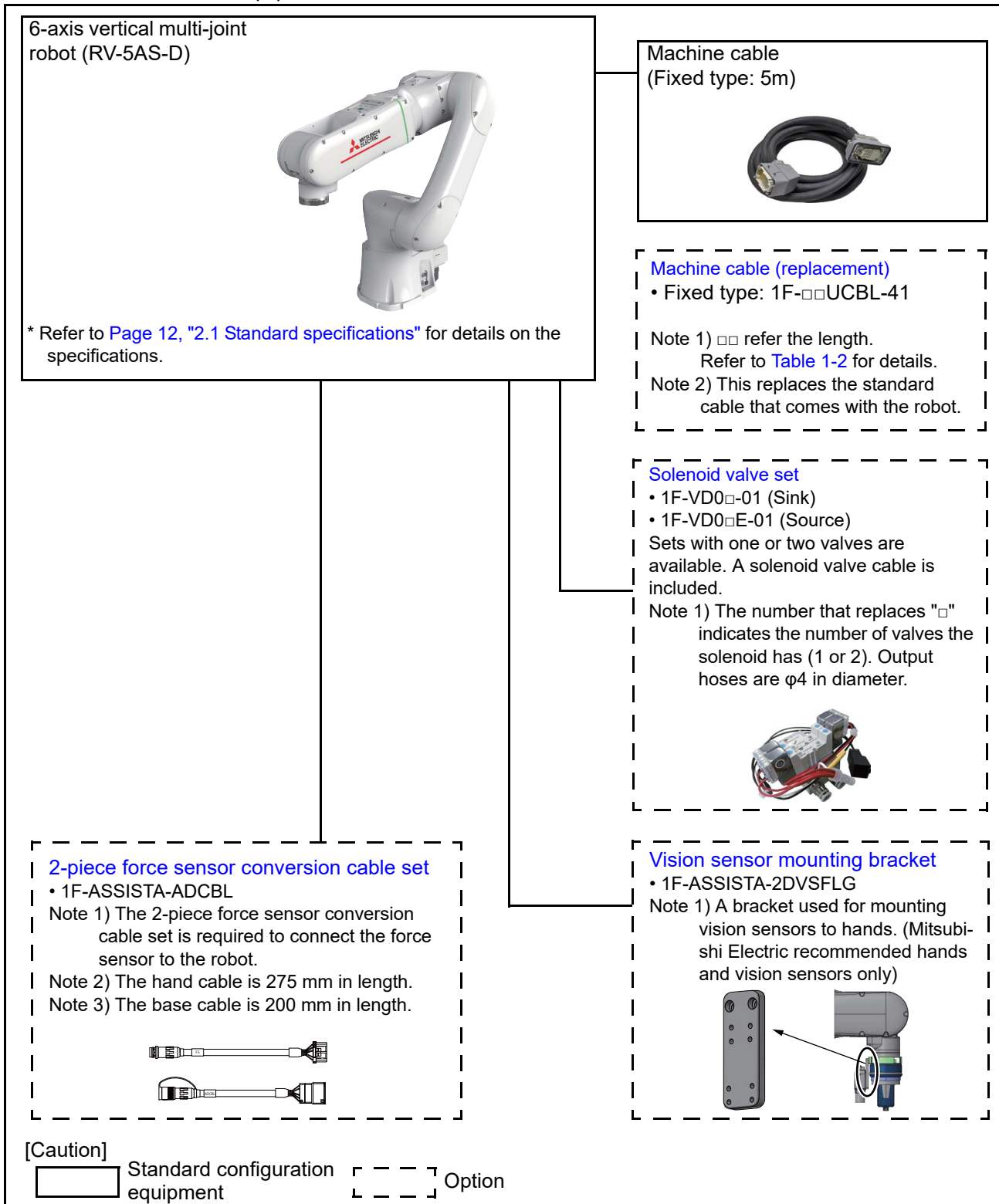

Fig.1-1: Structural equipment

1.3.2 Controller

The devices shown below can be installed on the controller.

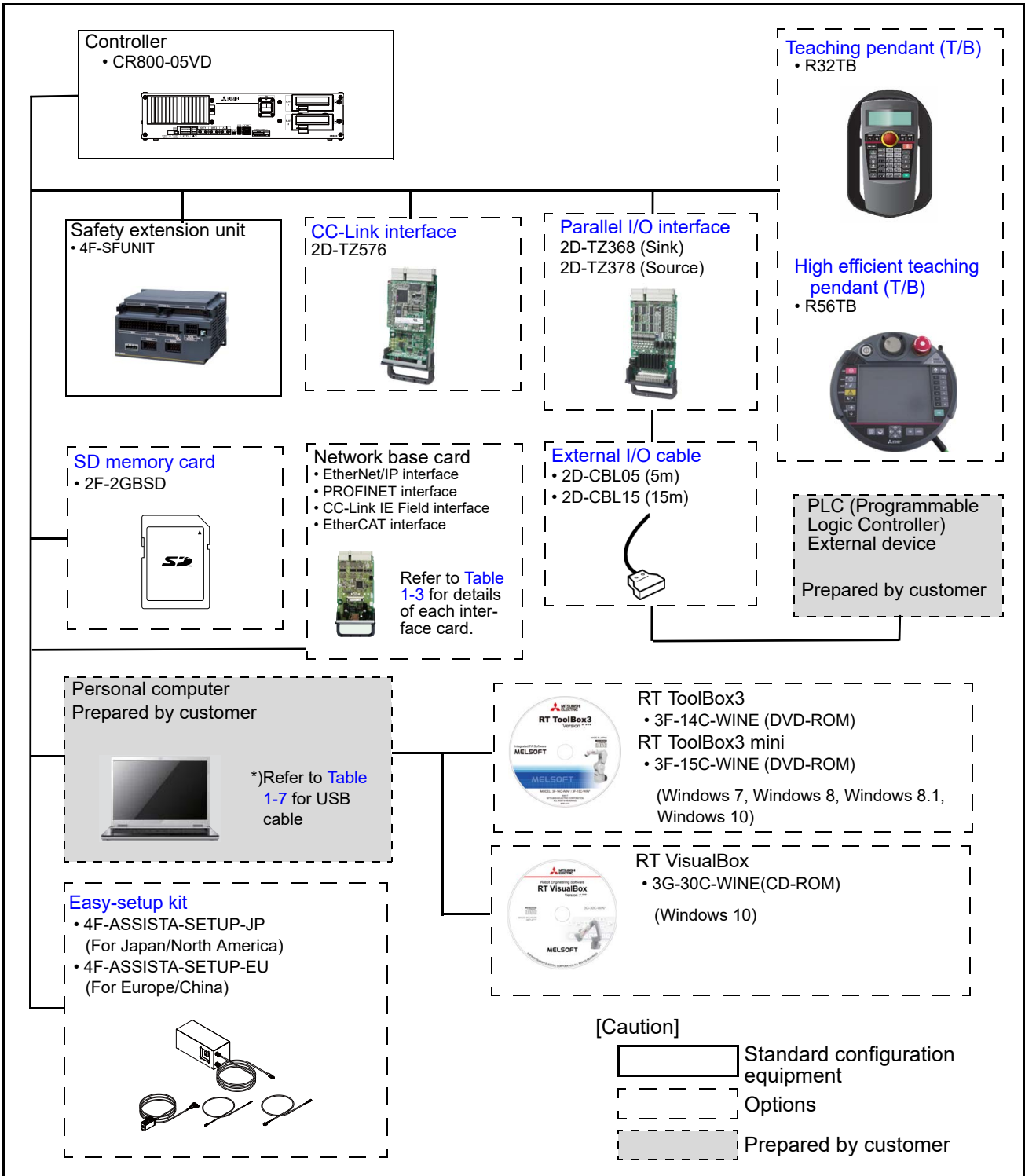

Fig.1-2: Structural equipment

1.3.3 Function extension device

These devices (option) are used to extend the function of the robot.

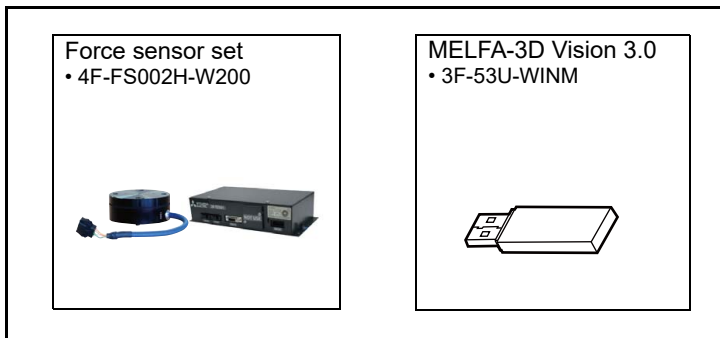
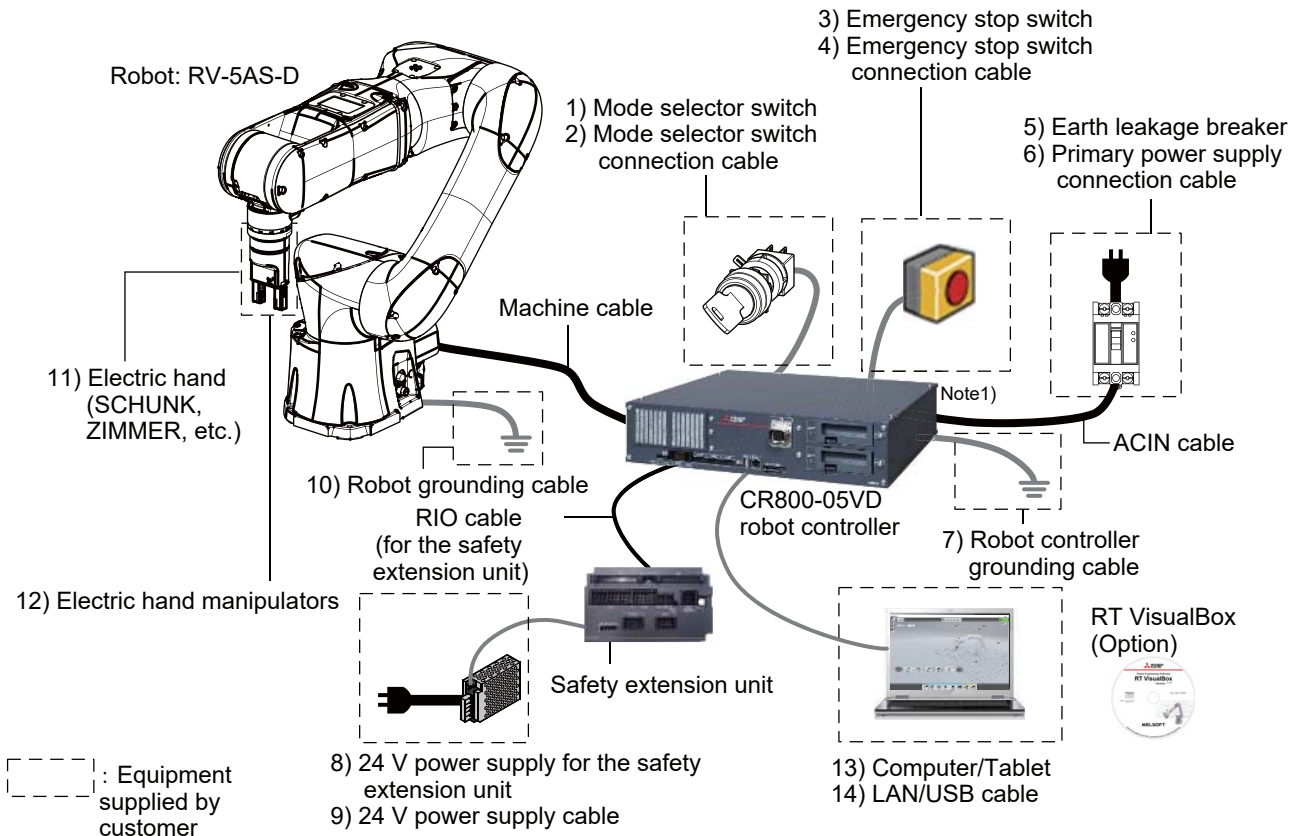

Fig.1-3: Function extension device

1.3.4 Minimum equipment required to operate the robot

The minimum amount of equipment required to operate the robot is shown below. Equipment that should be supplied by the customer is stated in Table 1-1 below.

Caution To protect against ground faults, connect an earth leakage breaker to the robot controller's primary power supply. Failure to do so may result in electric shock.



Note1) Short circuit pins 6-22 and 13-29 of the CNUSR11 connector if not using a door switch.

Fig.1-4: Minimum equipment required

Table 1-1: List of customer supplied equipment

No.	Name	Specifications/Recommended products
1)	Mode selector switch ^{Note1)}	Recommended product: HA1K-2C2A-2 (manufactured by IDEC)
2)	Mode selector switch connection cable ^{Note1)}	Refer to the mode selector switch catalog to select a connector cable.
3)	Emergency stop switch ^{Note1)}	Use an IEC 60204-1 compliant emergency stop switch, which has two NC contacts for redundancy and a mechanical latching function.
4)	Emergency stop switch connection cable ^{Note1)}	Refer to the emergency stop switch catalog to select a connector cable.
5)	Earth leakage breaker ^{Note1)}	Recommended product: Single phase NV30FAU-2P-10A-AC100-240V-30mA (manufactured by Mitsubishi Electric) Make sure to attach the TCS-05FA2 terminal cover (manufactured by Mitsubishi Electric).
6)	Primary power supply connection cable ^{Note1)}	Min. size: #14 AWG (2 mm ²)
7)	Robot controller grounding cable	Min. size: #14 AWG (2 mm ²)
8)	24 V power supply for the safety extension unit ^{Note1)}	Choose a product that meets the following specifications: Voltage: 24 VDC ±5% Max. current draw: 300 mA

No.	Name	Specifications/Recommended products
9)	24 V power supply cable ^{Note1)}	Recommended cable specifications <ul style="list-style-type: none"> • Conductor size: 0.5 to 1.42 mm² (20 to 16 AWG) • Outer sheath diameter: 1.8 to 2.8 mm • Shielded
10)	Robot grounding cable	Min. size: #11 AWG (4.2 mm ²)
11)	Electric hand	Use manipulators that satisfy the needs of the customer. Refer to Page 10, "1.4.5 Recommended hands" for recommended hands.
12)	Electric hand manipulators	Use a hand that satisfies the needs of the customer.
13)	Computer/Tablet	Refer to Page 77, "(4) MELSOFT RT VisualBox" .
14)	LAN cable/USB cable	LAN: 10BASE-T / 100BASE-TX USB: USB Type-A to Mini USB Type-B

Note1) Included with the Easy-setup kit (option). For further information on the Easy-setup kit, refer to [Page 91, "\(9\) Easy-setup kit"](#).

1.4 Contents of the Option equipment

A list of all Optional equipment is shown below.

1.4.1 List of the robot arm option equipment

Table 1-2: The list of robot option equipment

Item	Type	Specifications	Description
Machine cable (replacement)	1F-□□UCBL-41	For fixing	"□□" in type shows the length of the cables as follows. 02=2 m, 10=10 m (Changed from the original length of 5 m)
Solenoid valve set	1F-VD0□-01	Sink type	Sets with one or two valves are available. Φ4 diameter output hoses The number that replaces "□" indicates the number of valves the solenoid has (1 or 2).
	1F-VD0□E-01	Source type	
2-piece force sensor conversion cable set	1F-ASSISTA-ADCBL	The hand cable is 275 mm in length. The base cable is 200 mm in length.	2-piece force sensor conversion cable set (hand cable/base cable) required to connect the force sensor to the robot.
Vision sensor mounting bracket	1F-ASSISTA-2DVSFLG	-	Bracket required to connect a vision sensor to the hand.

1.4.2 List of the controller option equipment and special specification

Table 1-3: The list of the controller option equipment and special specification

Item	Type	Specifications	Description
Simple teaching pendant	R32TB	Cable length 7m	With 3-position enable switch IP65 Ver. 1.9.5 or later
	R32TB-15	Cable length 15m	
Highly efficient teaching pendant	R56TB	Cable length 7m	With 3-position enable switch IP65 Ver. 4.2 or later
	R56TB-15	Cable length 15m	
Parallel I/O Interface	2D-TZ368(Sink type)/ 2D-TZ378(Source type)	DO: 32 point DI: 32 point Insulated type output signal (0.1A/24V /point) Insulated type input signal (9mA/ 24V /point)	The card type external input-and-output. Interface. Install to the slot of controller.
External I/O cable (For Parallel I/O Interface)	2D-CBL05	5m	Use to connect the external peripheral device to the parallel input/output interface.
	2D-CBL15	15m	
CC-Link interface	2D-TZ576	Only Intelligent device station, Local station	For MELSEC PLC with CC-Link connection.
Network base card (EtherNet/IP interface)	2D-TZ535	Communication interface for mounting the Anybus CompactCom module manufactured by HMS. The customer needs to prepare the EtherNet/IP module (AB6314) manufactured by HMS.	Refer to separate volume "Network Base Card Instruction Manual" for details.
Network base card (PROFINET interface)	2D-TZ535-PN	Communication interface for mounting the Anybus CompactCom module manufactured by HMS. The customer needs to prepare the PROFINET IO module (AB6489-B) manufactured by HMS.	Refer to separate volume "Network Base Card Instruction Manual" for details.
Network base card (CC-Link IE Field interface)	2F-DQ535	Communication interface for mounting the Anybus CompactCom module manufactured by HMS. The customer needs to prepare the CC-Link IE Field module (AB6709) manufactured by HMS.	Refer to separate volume "Network Base Card Instruction Manual" for details.
Network base card (EtherCAT interface)	2F-DQ535-EC	Communication interface for mounting the Anybus CompactCom module manufactured by HMS. The customer needs to prepare the EtherCAT module (AB6707) manufactured by HMS.	Refer to separate volume "Network Base Card Instruction Manual" for details.
SD memory card	2F-2GBSD	Memory card capacity 2GB.	-

Item	Type	Specifications	Description
RT ToolBox3	3F-14C-WINE	DVD-ROM	Windows 7, Windows 8, Windows 8.1, Windows 10 Supporting English. (With the simulation function) Ver.1.70Y or later
RT ToolBox3 mini	3F-15C-WINE	DVD-ROM	Windows 7, Windows 8, Windows 8.1, Windows 10 Supporting English. Ver.1.70Y or later
RT VisualBox	3G-30C-WINE	CD-ROM	Windows 10 Supporting English.
Easy-setup kit	4F-ASSISTA-SETUP-JP	For Japan/North America.	A kit which aids setup that consists of switches, a connector cable, and a 24 V power supply.
	4F-ASSISTA-SETUP-EU	For Europe/China.	

1.4.3 Function extension device

Table 1-4: The list of function extension device

Item	Type name	Specifications	Remarks
Force sensor set	4F-FS002H-W200	A set of devices necessary for force sense control function, such as a force sensor, an interface unit, and support software.	Refer to separate volume "Force Sense Function Instruction Manual" for details.
MELFA-3D Vision 3.0	3F-53U-WINM	Software that connects a compact 3D vision sensor for robots to measure and recognize parts.	Refer to separate volume "MELFA-3D Vision 3.0 Instruction Manual" for details.

1.4.4 Recommended vision sensors

Table 1-5: List of recommended vision sensors

Type name	Manufacturer	Inquiries (As of April 2020)	Remarks
VS80M-202	Mitsubishi Electric	Mitsubishi Electric	Only available in Japan.
VS80M-202-R	Mitsubishi Electric	Mitsubishi Electric	Supports PatMax RedLine® PatMax RedLine® cannot be used with RT VisualBox. Only available in Japan.
In-Sight 8402M-363-50	COGNEX	COGNEX	-
In-Sight 8402M-373-50	COGNEX	COGNEX	Supports PatMax RedLine® PatMax RedLine® cannot be used with RT VisualBox.

PoE adapters and cables are required and sold separately. The following adapter and cable are recommended.

PoE adapter: CPS-AC-POE1A-JP (Manufactured by COGNEX)

PoE cable: CCB-84901-2001-## (Manufactured by COGNEX) (## represents the cable length.)

1.4.5 Recommended hands

Table 1-6: List of recommended hands

Type name	Manufacturer	Inquiries (As of April 2020)	Remarks
Co-act EGP-C40 N-N-Assista	SCHUNK	<p>Europe SCHUNK GmbH & Co. KG Bahnhofstrasse 106-134, 74348 Lauffen/Neckar, Germany Tel: +49-7133-103-0</p> <p>China SCHUNK Intec Precision Machinery Trading (Shanghai) Co., Ltd. Xinzhuang Industrial Park, 1F Building 1, No. 420 Chundong Road, Minhang District Shanghai 201108 Tel: +86-21-54420007</p>	<p>Electric hand Weight: 885 g (including installation parts and the fingers) Max. grasp force: 35 N / 70 N / 105 N / 140 N (Choose from four levels.) Stroke: 12 mm (6 mm in each direction) Allow an interval of 15 ms or more between when the Open hand signal is output and when the Close hand signal is output. For details, refer to the Instruction Manual of the hand.</p>
HRC-03-099455	ZIMMER	<p>Europe Zimmer Group Im Salmenkopf 5 77866 Rheinau - Germany Tel: +49 78 44 9139-0</p> <p>China ZIMMER GROUP CHINA LTD. Level 2-D3, Bldg 4, 526, Fu-Te East 3rd Rd. CN 200131 Pudong, Shanghai Tel: +86 2161 630506</p>	<p>Electric hand Weight: 962 g (including installation parts and the fingers) Max. grasp force: 50 N / 90 N / 140 N / 190 N (Choose from four levels.) Stroke: 20 mm (10 mm in each direction) Allow an interval of 10 ms or more between when the Open hand signal is output and when the Close hand signal is output. For details, refer to the Instruction Manual of the hand.</p>
KIT-ASSISTA-G	GIMATIC	<p>Europe Gimatic Srl Via Enzo Ferrari 2/4 25030 Roncadelle (Bs) Italy Tel: +39 030 2584655</p> <p>China GIMATIC AUTOMATION ENGINEERING (CHANGSHU) CO., LTD ROOM 902, N. 333, SOUTHEAST AVENUE CHANGSHU RC 215500 Tel: +86051252977396</p>	<p>Electric hand (Fingers must be created.) Weight: 922 g (including installation parts) Grasp force: 98 N Stroke: 35 mm (17.5 mm in each direction)</p>
ROB-SET ECBPM ASSISTA	SCHMALZ	<p>Europe J. Schmalz GmbH Johannes-Schmalz-Str.1 DE-72293 Glatten Tel: +49 7443 2403-0</p> <p>China J. Schmalz GmbH Johannes-Schmalz-Str.1 DE-72293 Glatten Tel: +49 7443 2403-0</p>	<p>Suction hand Weight: 750 g (including installation parts and the suction pad) Maximum vacuum pressure: -60 kPa Flow rate: 1.6 liters per minute</p>

[Reference]:The recommendation products of the USB cable are shown below

Table 1-7: Recommendation article of the USB cable

Name	Type name	Supplier	Outside dimensions
USB cable (USB A type-USB mini B type)	GT09-C30USB-5P	MITSUBISHI ELECTRIC SYSTEM & SERVICE CO., LTD.	Fig. 1-5
	MR-J3USBCBL3M	MITSUBISHI ELECTRIC CORPORATION.	Fig. 1-6

Caution Be careful to the USB cable to apply neither the static electricity nor the noise. Otherwise, it becomes the cause of malfunction.

Caution Use the network equipments (personal computer, USB hub, LAN hub, etc) confirmed by manufacturer. The thing unsuitable for the FA environment (related with conformity, temperature or noise) exists in the equipments connected to USB. When using network equipment, measures against the noise, such as measures against EMI and the addition of the ferrite core, may be necessary. Please fully confirm the operation by customer. Guarantee and maintenance of the equipment on the market (usual office automation equipment) cannot be performed.

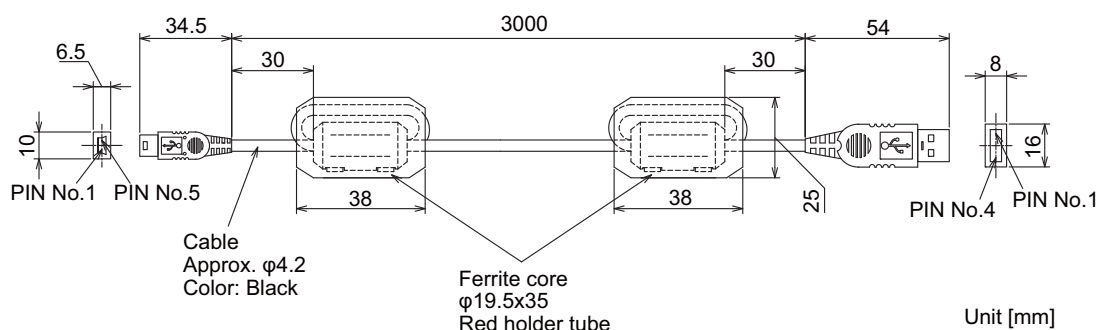

Fig.1-5: USB cable (GT09-C30USB-5P)

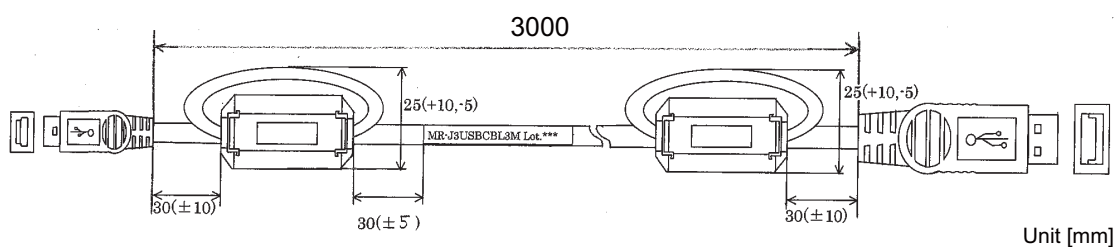

Fig.1-6: USB cable (MR-J3USBCBL3M)

2 Robot arm
 2.1 Standard specifications
 2.1.1 Basic specifications

Table 2-1: Standard specifications of RV-5AS-D robot

Item		Unit	Specifications
Type			RV-5AS-D
Environment			Oil mist environments
Degree of freedom			6
Installation posture			Floor mounted / ceiling mounted
Structure			Vertical, multiple-joint type
Drive system			AC servo motor (brake provided on all axes)
Position detection method			Absolute encoder
Motor capacity	Waist (J1)	W	200
	Shoulder (J2)		200
	Elbow (J3)		150
	Wrist twist (J4)		100
	Wrist pitch (J5)		100
	Wrist roll (J6)		50
Operating range	Waist (J1)	Degree	±240
	Shoulder (J2)		±148
	Elbow (J3)		±150
	Wrist twist (J4)		±200
	Wrist pitch (J5)		±120
	Wrist roll (J6)		±200
Speed of motion ^{Note1)}	Waist (J1)	Degree/s	124 (59.6)
	Shoulder (J2)		124 (34.0)
	Elbow (J3)		124 (34.0)
	Wrist twist (J4)		297 (142)
	Wrist pitch (J5)		356 (215)
	Wrist roll (J6)		360
Maximum reach radius (P point)		mm	910
Maximum resultant velocity ^{Note2)}	High-speed operation mode	mm/sec	1,000
	Collaborative operation mode (Standard operation)		250
	Collaborative operation mode (Low-speed operation)		50
Load	Rating	kg	5
	Maximum ^{Note3)}		5.5
Pose repeatability ^{Note4)}		mm	±0.03
Ambient temperature ^{Notes)}	In use	°C	0 to 40
	At transport/storage		-20 to 70 (Without freeze)
Ambient humidity	In use	%RH	45 to 85
	At transport/storage		95 or less (Without dew drops)
Mass		kg	32
Total mass of the moving parts of the robot		kg	27
Allowable moment load	Wrist twist (J4)	N•m	12.8
	Wrist pitch (J5)		12.8
	Wrist roll (J6)		4.9

Item		Unit	Specifications
Allowable inertia	Wrist twist (J4)	kg·m ²	0.34
	Wrist pitch (J5)		0.34
	Wrist roll (J6)		0.10
Wiring	Hand I/O	-	Mechanical interface: 2 inputs/4 outputs Forearm: 6 inputs/0 outputs Base: 0 inputs/4 outputs
	Force sensor cable/ Spare cable	-	5-conductor (24 V/0.7 A) One of the conductors should be used for the frame ground (FG).
	LAN cable	-	Cat-5e supported
Plumbing	Primary hoses	-	Φ6 × 2
	Secondary hoses	-	Φ4 × 4 From the base of the robot to the elbow.
Supply pressure		MPa	0.54
Protection specification ^{Note6)} ^{Note7)}		-	IP54 (ISO Class 5 ^{Note8)})
Status indicator LED		-	Six colors: red, yellow, green, blue, white, and light blue. ^{Note9)}
Painting color		-	Light gray (Equivalent to Munsell: 0.6B7.6/0.2, PANTONE: 428C)
External magnetic field		mT	Less than 10 ^{Note10)}

Note1) Values in parentheses indicate the maximum speed when the input voltage is single-phase 100 to 120 VAC.

Note2) These values represent the maximum overall speed of all axes combined. The safety functions limit the robot to the speeds shown in the table. For accurate collision force data when the robot is in Collaborative operation mode, measure collision forces under actual operating conditions.

For further information on safety functions, refer to the section "Safely-limited speed function (SLS)" in the Function Manual.

Note3) Allowable load when the mechanical interface faces downward at an inclination within ±10° to the vertical direction. Please note that when confirming the contact force that occurs in a collision and when confirming the stopping time and stopping distance at our company, the maximum payload is set to the rated payload of 5.0 kg.

Note4) The pose repeatability details are given in [Page 14, "2.2.1 Pose repeatability"](#)

Note5) Sets the robot's operating environmental temperature as parameter OLTMX. The initial value is 30 (°C). Corresponding to the environment, the continuous control action performance and the overload-protection function are optimized. (Refers to "Optimizing the overload level" described in "Chapter 5 Functions set with parameters" of separate instruction manual/ Detailed explanations of functions and operations for details.)

Note6) The protection specification details are given in [Page 17, "2.2.6 Protection specifications"](#).

Note7) The protection performance may not be ensured depending on the oil characteristics. Please consult the dealer.

Note8) Clean-room specifications are based on values acquired from Mitsubishi Electric's in-house tests.

Note9) For further information on the meaning of each color, refer to [Page 21, "2.3.2 Status indicator LED"](#).

Note10) Do not place a magnet on the robot surface.

2.1.2 The counter-force applied to the installation surface

The counter-force applied to the installation surface for the strength design of the robot installation surface is shown.

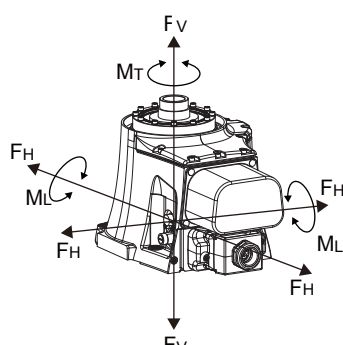

Table 2-2: Value of each counter-force

Item	Unit	Value
Falls moment: M_L	N·m	325
Torsion moment: M_T	N·m	275
Horizontal translation force: F_H	N	700
Vertical translation force: F_V	N	1,010

2.2 Definition of specifications

The accuracy of pose repeatability mentioned in catalogs and in the specification manual is defined as follows.

2.2.1 Pose repeatability

For this robot, the pose repeatability is given in accordance with JIS B 8432 (Pose repeatability). Note that the value is based on 100 measurements (although 30 measurements are required according to JIS).

[Caution] The specified "pose repeatability" is not guaranteed to be satisfied under the following conditions.

[1] Operation pattern factors

- 1) When an operation that approaches from different directions and orientations are included in relation to the teaching position during repeated operations
- 2) When the speed at teaching and the speed at execution are different

[2] Load fluctuation factor

- 1) When work is present/absent in repeated operations

[3] Disturbance factor during operation

- 1) Even if approaching from the same direction and orientation to the teaching position, when the power is turned OFF or a stop operation is performed halfway

[4] Temperature factors

- 1) When the operating environment temperature changes
- 2) When accuracy is required before and after a warm-up operation

[5] Factors due to differences in accuracy definition

- 1) When accuracy is required between a position set by a numeric value in the robot's internal coordinate system and a position within the actual space
- 2) When accuracy is required between a position generated by the pallet function and a position within the actual space

2.2.2 Rated load (mass capacity)

The robot's mass capacity is expressed solely in terms of mass, but even for tools and works of similar mass, eccentric loads will have some restrictions. When designing the tooling or when selecting a robot, consider the following issues.

- (1) The tooling should have the value less or equal than the smaller of the allowable inertia and the allowable moment found in [Page 12, "2.1.1 Basic specifications"](#).
The examples of inertia calculation methods are described in [Page 110, "Appendix 1: Inertia calculation method"](#).
- (2) [Fig. 2-1](#) shows the distribution dimensions for the positions of the centers of gravity for loads with relatively small volume. Refer to the figure for designing tooling.
- (3) Even if the load is force, not the mass, design the tooling so that moment does not exceed the allowable moment. Refer to [Page 12, "2.1 Standard specifications"](#) for details of allowable moment value.

[Caution] The mass capacity is greatly influenced by the operating speed of the robot and the motion posture. Even if you are within the allowable range mentioned previously, an overload or generate an overcurrent alarm could occur. In such cases, it will be necessary to change the time setting for acceleration/deceleration, the operating speed, and the motion posture.

[Caution] The overhang amount of the load, such as the mass capacity and the allowable moment of inertia defined in this section, are dynamic limit values determined by the capacity of the motor that drives axes or the capacity of the speed reducer. Therefore, it does not guarantee the accuracy on all areas of tooling. Guaranteed accuracy is measured from the center point of the mechanical interface surface. Please note that if the point of operation is kept away from the mechanical interface surface by long and low-rigid tooling, the positioning accuracy may deteriorate or may cause vibration.

[Caution] Even within the allowable range previously mentioned, an overload alarm may be generated if an ascending operation continues at a micro-low speed. In such a case, it is necessary to increase the ascending speed.

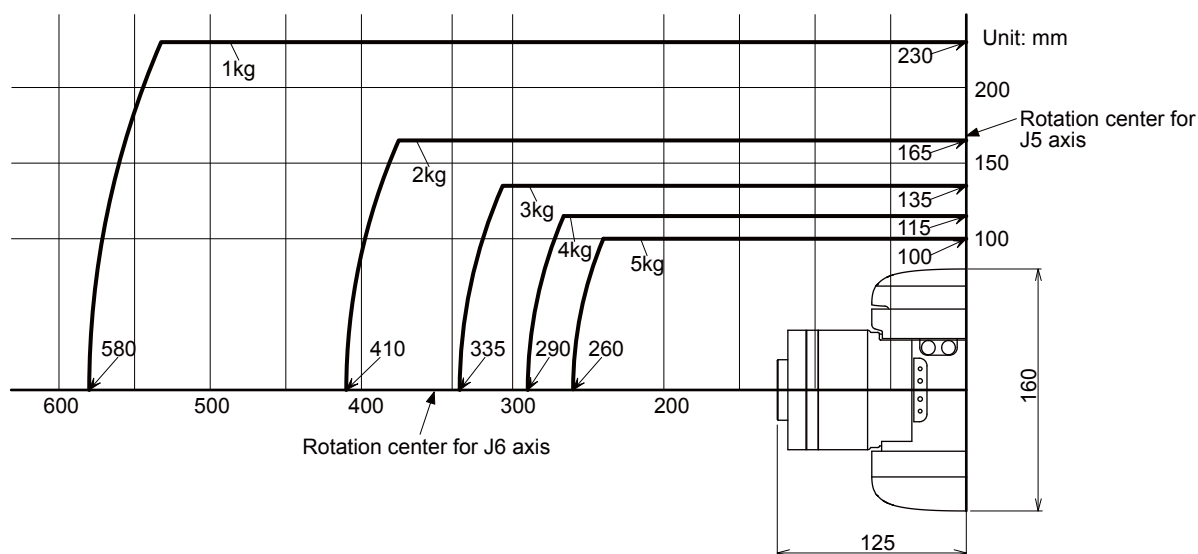

Fig.2-1: Positions of the centers of gravity for loads with relatively small volume

2.2.3 Relationships Among Mass Capacity, Speed, and Acceleration/Deceleration Speed

This robot automatically sets the optimum acceleration and deceleration speeds and maximum speed, according to the load capacity and size that have been set, and operates using these automatically set speeds.

To achieve that, it is necessary to correctly set the actual load data (mass and size of hand and work) to be used. However, vibration, overheating and errors such as excessive margin of error and overload may occur, depending on the robot operation pattern or ambient temperature. In such a case, change the setting value to the +20% range.

If a setting is performed in such a way that it falls below the mounted load, the life span of the mechanism elements used in the robot may be shortened.

(1) Setting hand and workpiece conditions

The parameters "HNDDAT*" and "WRKDAT*" are used to set the mass and size of the hand and workpiece. The numbers 0 to 8 (nine settings) can be set in place of "*".

The default settings of these parameters after power on are "HNDDAT0" and "WRKDAT0".

The hand's mass and center of gravity position for parameter HNDDAT0 can be set with RT VisualBox.



WARNING

The settings of HNDDAT* have an effect on direct teaching.

If unsatisfactory values are set in HNDDAT*, the robot may move unexpectedly during direct teaching. The safe torque range function (STR) may also not function correctly. The force generated upon an impact may also be larger than if the correct values were set, and errors may occur during operation.

<Factory settings>

	Hand mass	Size X	Size Y	Size Z	Center-of-grav- ity position X	Center-of-grav- ity position Y	Center-of-grav- ity position Z
	[kg]	[mm]	[mm]	[mm]	[mm]	[mm]	[mm]
HNDDAT* =	0.0	0.0	0.0	00.0	0.0	0.0	0.0
WRKDAT* =	0.0	0.0	0.0	0.0	0.0	0.0	0.0

2.2.4 Vibrations at the Tip of the Arm during Low-Speed Operation of the Robot

Vibrations at the tip of the arm may increase substantially during the low-speed operation of the robot, depending on the combination of robot operation, hand mass and hand inertia. This problem occurs when the vibration count specific to the robot arm and the vibration count of the arm driving force are coming close to each other. These vibrations at the tip of the arm can be reduced by taking the following measures:

- 1) Lower the robot's operating speed by approximately 5% from high speed using the OvrD command.
- 2) Change and move the teaching points of the robot.
- 3) Change the hand mass and hand inertia.

2.2.5 Collision detection

This series of robots has the "Collision detection function", which detects torque differences caused by collisions with the robot arm. This function is set to "disabled" from the factory. It is not a safety function. This function can be enabled/disabled with the COL parameter or ColChk command. Enable this function to protect the robot and peripheral devices.

The abnormalities are detected by the robot's kinetics model, presuming torque necessary for movement at any time. Therefore, the setting parameter (HNDDAT*, WRKDAT*) of the hand and the work piece conditions should be right. And, it may be detected as the collision in movement as speed and motor torque are changed rapidly. (for example, the movement near the place of the origin by linear interpolation, the reversal movement, the cold condition, the operation after long term stoppage)

In such a case, by adjusting the value of the setting parameter (COLLVL, COLLVLJG) of the collision detection level according to actual use environment, the sensitivity of collision detection can be optimized and the damage risk can be reduced further. And, in the operation after the low temperature or long term stoppage, please operate by accustoming at low speed (warm-up), or use the warm-up operation mode.

Refer to the separate instruction manual "Detailed explanations of functions and operations" for details of related parameter.

Table 2-3: Factory-shipments condition

	JOG operation	Automatic
RV-5AS-D	Invalid	Invalid

2.2.6 Protection specifications

(1) Types of protection specifications

The robot arm has protection specifications that comply with the IEC Standards. The protection specifications and applicable fields are shown in [Table 2-4](#).

Table 2-4: Protection specifications and applicable fields

Type	Protection specifications (IEC Standards value)	Classification	Applicable field	Remarks
RV-5AS-D	IP54	Oil mist specifications	Machine tool (cutting) Machine shop with heavy oil mist Dusty work shop	-

The IP numbers stated in IEC ratings indicate the ingress protection level against solid objects and water. They do not indicate that the product's enclosure protects against oil. A definition of the IEC rating is stated in "Information" below. Certain liquids may cause the robot to rust or corrode.

[Information]

- The IEC IP54

[Degree of protection against solids]

A protective enclosure which prevents dust particles from interfering with sproper operation of the product and compromising safety.

[Degree of protection against water]

A protective enclosure that can withstand the following:

Fresh-water spray in any direction 180° from vertical at a distance of 300 to 500 mm with a water volume of 10±0.5 L/min at 50 to 150 kPa over 1 m2 for a minimum of 10 minutes.

(2) About the use with the bad environment

This robot has protection methods that conform to IEC IP54 standards.

Usage conditions are shown below.

- 1) The robot is designed for use in combination with machining device.
- 2) The inside of the robot arm can be pressurized to ensure that the robot reliably meets IP54 beyond the warranty period. The robot has two $\phi 6$ couplings on the side of the base (Refer to Fig. 2-6.). The coupling marked with RETURN (one of the two couplings) can be used for supplying dry air to pressurize the robot instead of connecting solenoid valves. Table 2-6 lists recommended air purging equipment.

Table 2-5: Specification of the dry air for pressurization

Item	Dew point	Pressure
Specification	The atmospheric pressure dew point is -20 degree or less.	0.01MPa or less

Table 2-6: Recommended air purge equipment

Item	Part name	Required number	Manufacture
Membrane air dryer	IDG3M-02C-S	1	SMC
Precision regulator	IR1000-01G	1	SMC
Spacer (Connection part)	Y20	1	SMC

- 3) We have confirmed that the robot arm meets the protection specifications by testing it using our specified cutting oil. However, the parts of the controller may be damaged by the cutting oil. When using the controller in oil mist environments, protect the controller from oil mist appropriately. Our warranty does not cover damages or failure resulting from the robot being operated in any environment where other cutting oils than those listed in the table are used (except cutting oils with respect to which the robot's compatibility with the protection specification is verified through our operability evaluation) or where the robot body may be directly splashed with water, oil or dust in quantities larger than stated in the protection specification.
- 4) Take measures so that the robot will not be exposed to water, oil and/or chips for a long period of time.

Also, entrained water droplets lead to the formation of rust on the robot, but would not usually affect the robot's ability to operate normally.

The warranty is invalid for any faults that occur when the robot is used under the following conditions.

Also, if the cover and/or other parts are damaged by interferences caused by the peripheral devices and the robot, the protection specification (seal performance, etc.) may be degraded. Therefore, please pay extra attention when handling the robot.

Refer to Page 106, "6.2 Working environment".

- 1) In surroundings that generate inflammable gases or corrosive gasses.
- 2) Atmosphere of the mist containing polish liquid etc.
- 3) Atmosphere in which the water, the oil, and the dust exceeding protection specification fall on the robot arm directly.

2.3 Names of each part of the robot

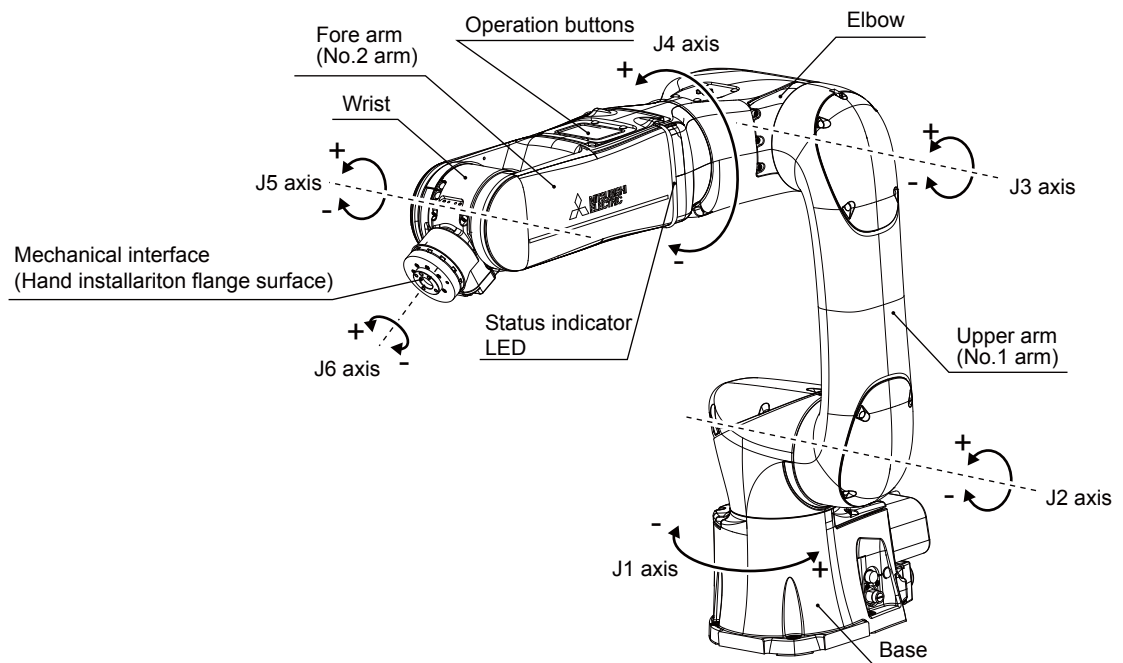
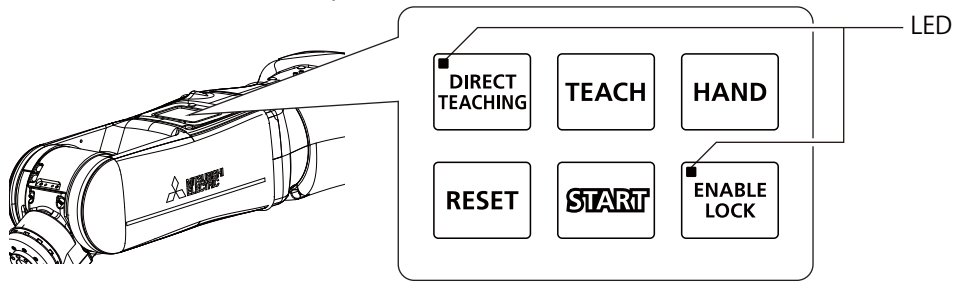

Fig.2-2: Names of each part of the robot

2.3.1 Operation buttons

Operation buttons are located on the top of the forearm.



Button	Description
	Hold for 2+ seconds to turn direct teaching On/Off. Press once to change the direct teaching mode.
	Press once to teach a position. RT VisualBox is required for it to be possible to teach positions using this button.
	Hold for 2+ seconds to align the hand. Press once to open/close the hand.
	When errors occur: Press once to reset errors. While programs are suspended: Press once to reset the program.
	When collaborative operation has stopped: Hold for 2+ seconds to execute the program from the start. While collaborative operation is suspended: Hold for 2+ seconds to restart the program from the current command.
	Press once to enable/disable the lock. Taking control of operation rights via this button prevents other devices from operating the robot.

⚠ CAUTION Before opening/closing the hand, ensure that doing so will not cause workpieces to fall or fingers to become trapped.

2.3.2 Status indicator LED

The status indicator LED is located on the forearm.

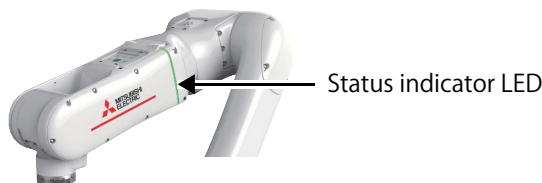

Color	Description	
	On	Flashing
Red	Low-level error	High level error
Yellow	Warning (Low-speed operation/Standard operation) ^{Note1)}	Warning (High-speed operation)
Blue	Stopped (Low-speed operation/Standard operation)	Stopped (High-speed operation)
Green	Collaborative operation mode (Low-speed operation)	Collaborative operation mode (Standard operation)
White	-	High-speed operation mode
Light blue	Servo OFF	Controller restarting (not including times when the software is rebooted)

Note1) If functional safety is not ensured (such as when the safety extension unit is not connected and no origin position has been set) or the robot servos are turned off, the status indicator LED will flash.

CAUTION Under certain lighting, the colors of the Status indicator LED may become difficult to distinguish. Ensure that this does not result in unintended operation.

The following table shows conditions of dedicated output signals that determine the robot status (shown by the color and behavior of the status indicator LED).

The status of dedicated output signals is checked from the top to the bottom of the table, and when the condition is met, the status of the robot will be determined accordingly.

Refer to this table when installing an extra status indicator light.

For information on the dedicated output signals, refer to the separate "Instruction Manual: Detailed explanations of functions and operations" and "Collaborative Robot: Detailed explanations of functions and operations".

Color	Description	
	On	Flashing
Red	Low level error: LLVLERR output signal = ON	High level error: HVLERR output signal = ON
Yellow	Low-speed operation: SFMODE output signal (default setting: 8) = ON Warning level error: CLVLERR output signal = ON	High-speed operation: SFMODE output signal (default setting: 6) = ON Warning level error: CLVLERR output signal = ON
	Standard operation: SFMODE output signal (default setting: 7) = ON Warning level error: CLVLERR output signal = ON	Collaborative operation mode (No meaning): SFMODE output signal (default setting: 6, 7, 8) = OFF ^{Note1)} Warning level error: CLVLERR output signal = ON
Light blue	Robot controller turned ON: RCREADY output signal = ON Servo OFF: SRVON output signal (default setting: 1) = OFF	Robot controller not turned ON: RCREADY output signal = OFF

Color	Description	
	On	Flashing
White	-	High-speed operation: SFMODE output signal (default setting: 6) = ON During operation: START output signal (default setting: 0) = ON
Green	Low-speed operation: SFMODE output signal (default setting: 8) = ON During operation: START output signal (default setting: 0) = ON	Standard operation: SFMODE output signal (default setting: 7) = ON During operation: START output signal (default setting: 0) = ON
	Low-speed operation: SFMODE output signal (default setting: 8) = ON Direct teaching ON: DTON output signal = ON	Standard operation: SFMODE output signal (default setting: 7) = ON Direct teaching ON: DTON output signal = ON
Blue	Low-speed operation: SFMODE output signal (default setting: 8) = ON During standby or stop: START output signal (default setting: 0) = OFF Direct teaching OFF: DTON output signal = OFF	High-speed operation: SFMODE output signal (default setting: 6) = ON During standby or stop: START output signal (default setting: 0) = OFF Direct teaching OFF: DTON output signal = OFF
	Standard operation: SFMODE output signal (default setting: 7) = ON During standby or stop: START output signal (default setting: 0) = OFF Direct teaching OFF: DTON output signal = OFF	

Note1) Collaborative operation mode (No meaning) if functional safety is not ensured (such as when the safety extension unit is not connected and no origin position has been set) or the robot servos are turned off.

2.4 Outside dimension • Operating range diagram

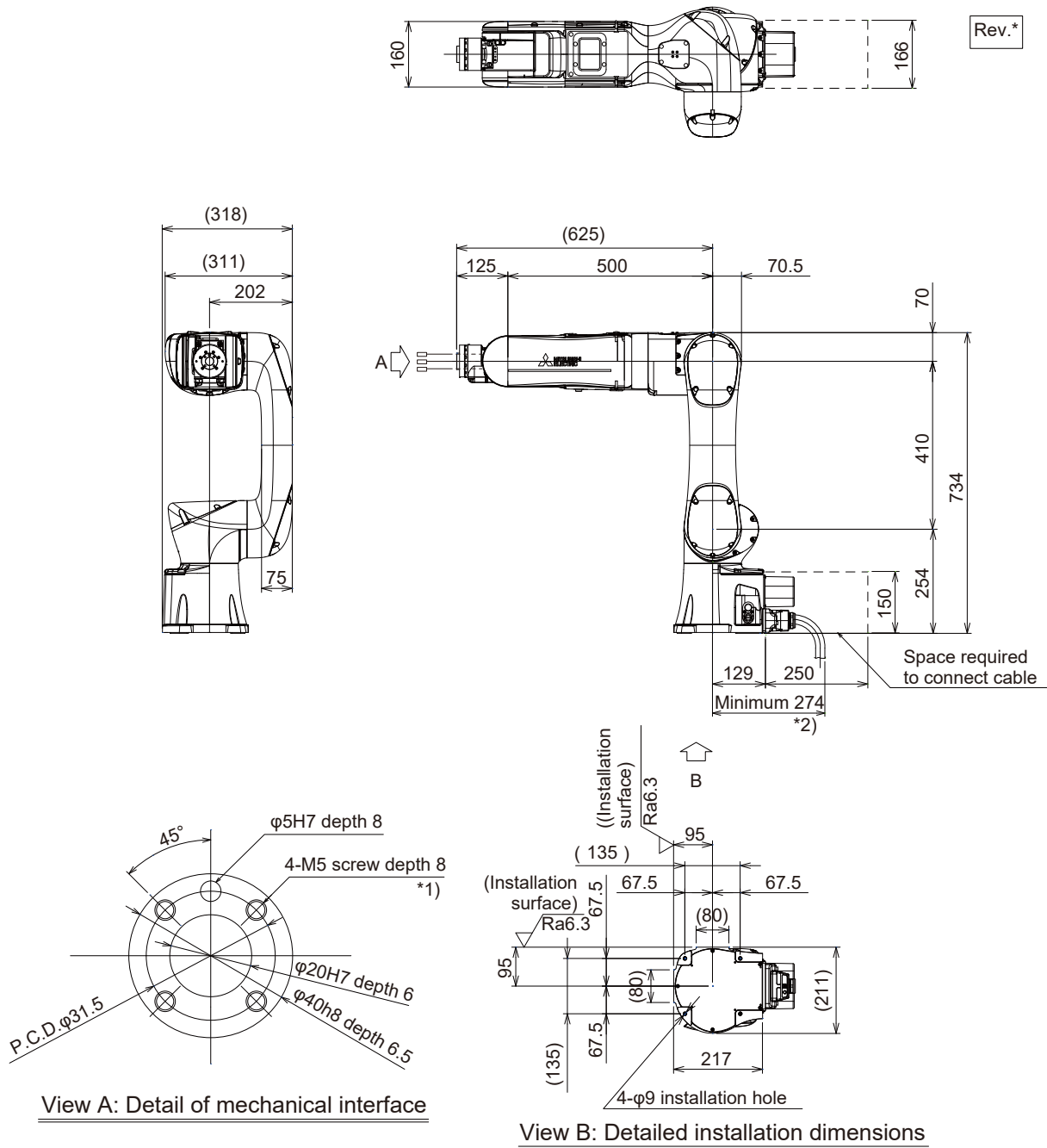

*1) The depth in which the screw is tightened is 7.5 to 8mm.

*2) Dimensions including the minimum bending radius of the machine cable.

Fig.2-3: Outside dimensions

Note) Don't install the robot arm in the position where direct rays or the heat of lighting hits. The skin temperature of the robot arm may rise, and the error may occur.

■ Marking and rating plate

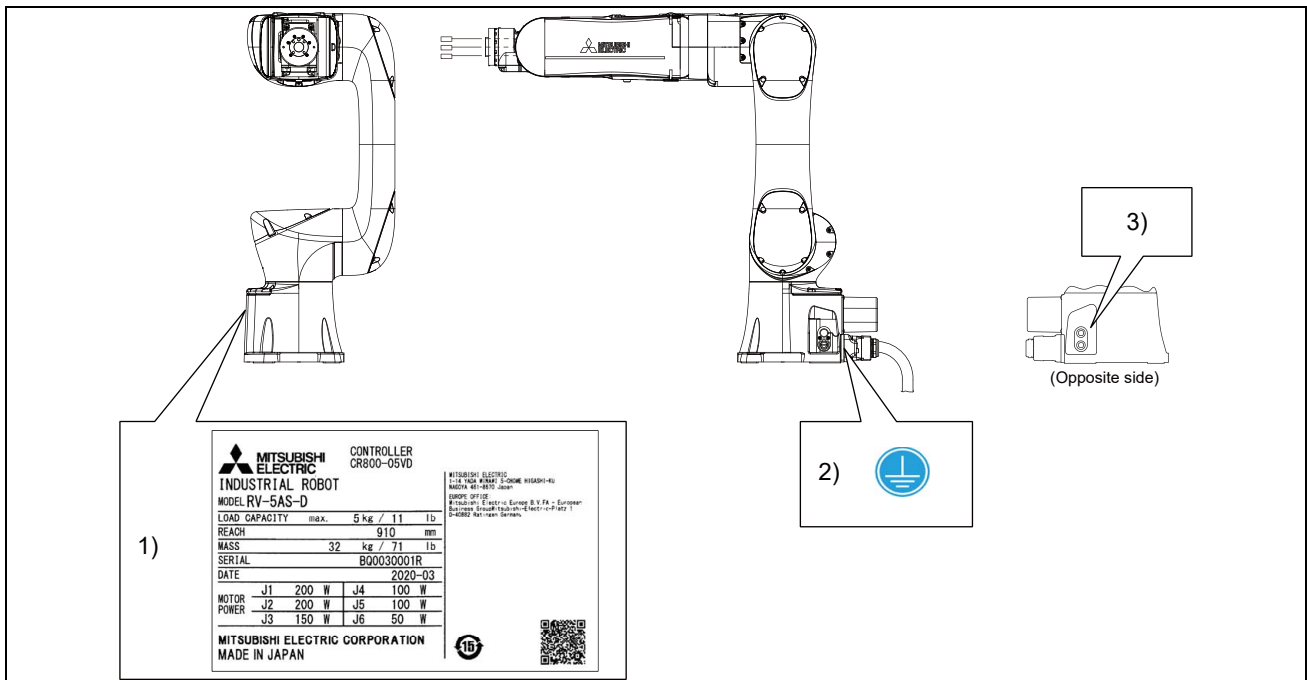

Fig.2-4: Locations of the marking and rating plate

Table 2-7: Details of the marking and rating plate

No.	Description	Details
1)	Rating plate	<p>Robot model</p> <p>Load capacity</p> <p>Arm reach</p> <p>Mass (kg/lb)</p> <p>Serial No.</p> <p>Date of manufacture</p> <p>Motor power</p>
2)	Protective earth symbol	
3)	Maximum supply pressure	AIR IN MAX. 0.54 MPa

The following figure shows a robot at the position of:
 $J1=0^\circ$, $J2=0^\circ$, $J3=90^\circ$, $J4=0^\circ$, $J5=0^\circ$, and $J6=0^\circ$

(Rev.*)

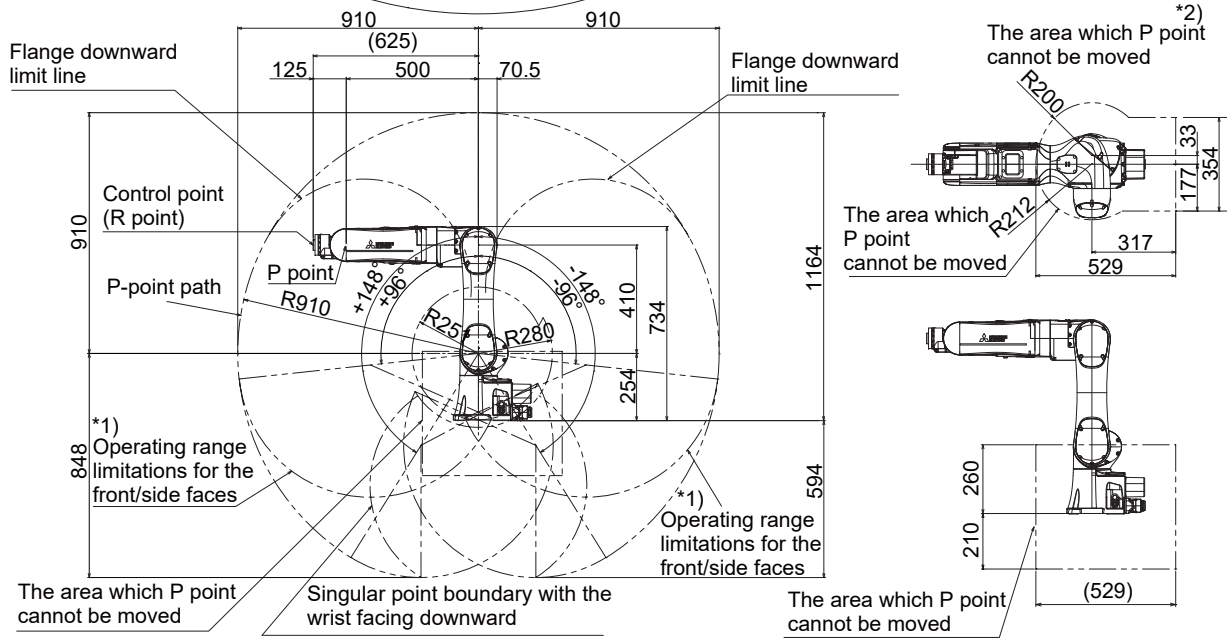
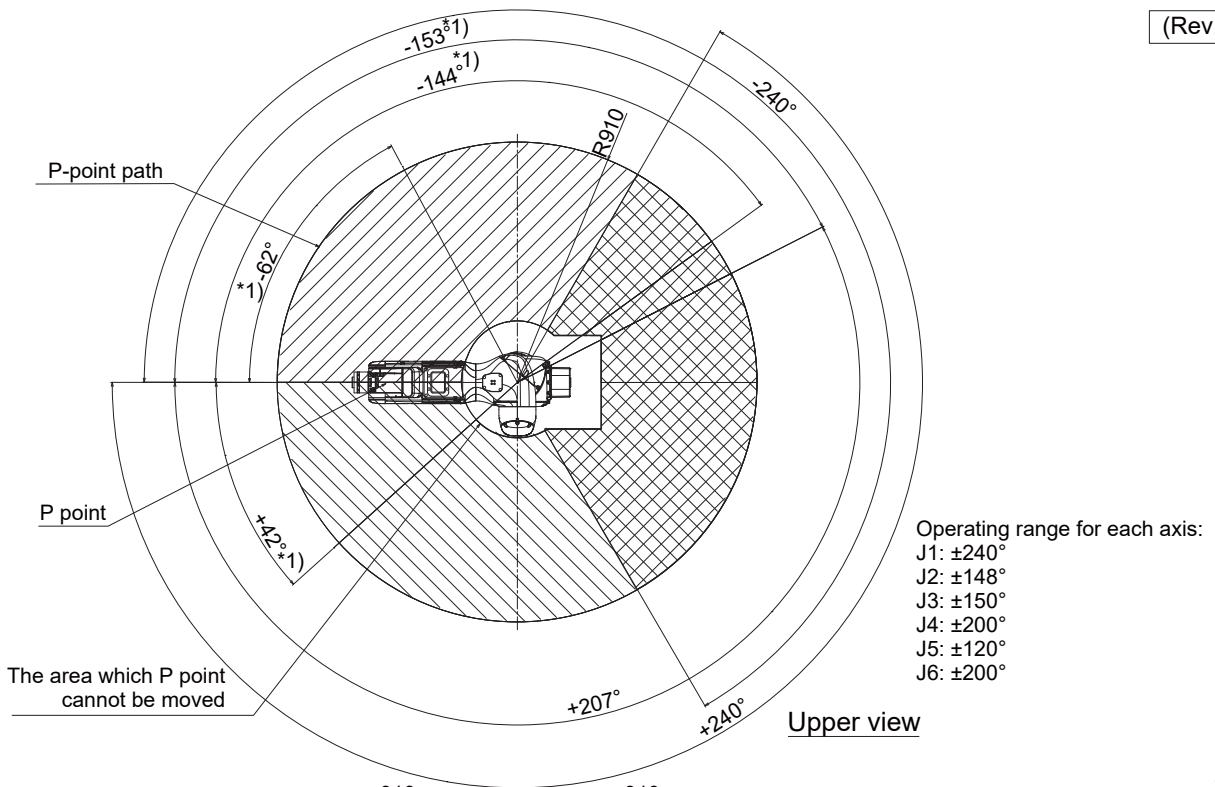

- *1) Limits of the front operating range:
 If the angle of $J1$ is $-62^\circ \leq J1 \leq +207^\circ$ or $J1 \leq -153^\circ$, then $J2$ is limited to $-96^\circ \leq J2$.
 If the angle of $J1$ is $+42^\circ \leq J1$ or $J1 \leq -144^\circ$, then $J2$ is limited to $J2 \leq +96^\circ$.
 If the angle of $J2$ is $J2 \leq -95^\circ$, then $J3$ is limited to $J3 \leq +146^\circ$.
 If the angle of $J2$ is $J2 \leq +30^\circ$, then $J3$ is limited to $-146^\circ \leq J3$.

- *2) P point prohibited area:
 P point cannot enter the area shown in the diagram. However, parameter "MELTEXS" can be used to disable the P point prohibited area. The prohibited area is enabled from the factory.

Fig.2-5: Operating range diagram

2.4.1 Outside dimensions of machine cables

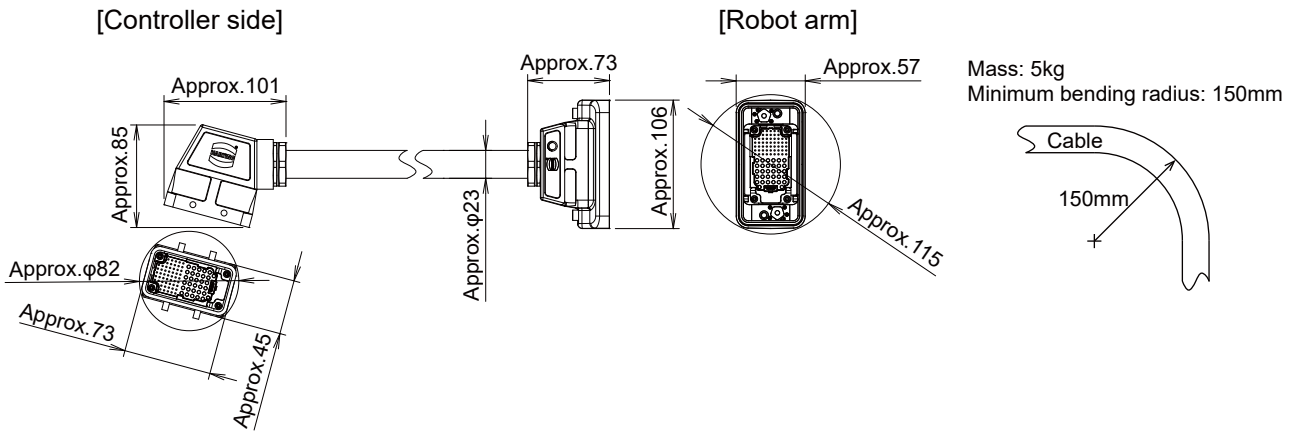

2.5 Tooling

2.5.1 Wiring and piping for hand

Shows the wiring and piping configuration for a standard-equipped hand.

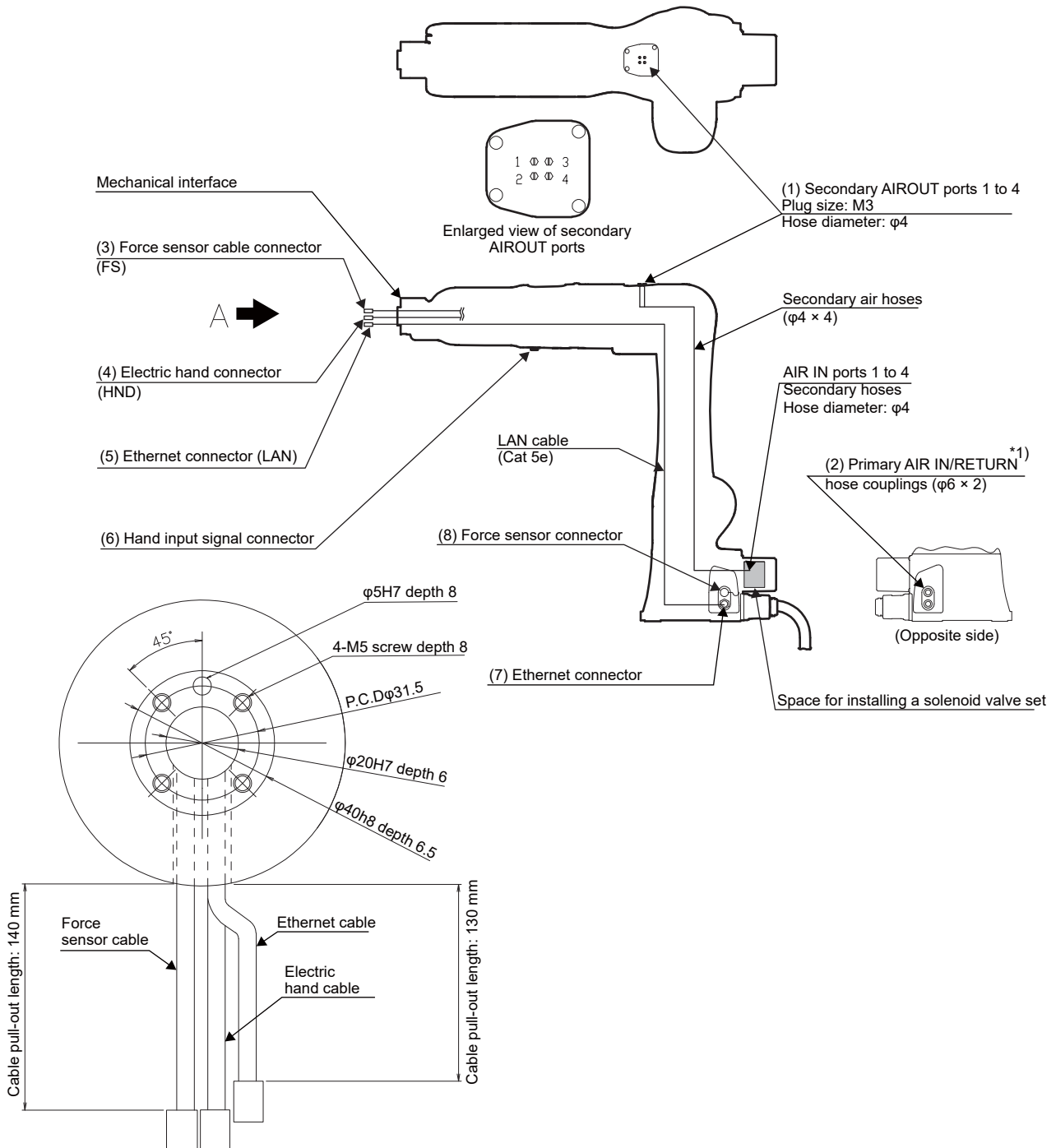

View A: Front view of the mechanical interface

*1)The coupling marked with RETURN can be used for supplying dry air to pressurize the robot instead of connecting solenoid valves. Recommended air purging equipment is listed in [Table 2-6](#).

Fig.2-6: Wiring and piping for hand

Table 2-8: Connector and pneumatic coupling

No	Name	Qty.	Robot side (Robot arm side)	Counter side (customer-prepared)	Manufacturer	Remarks
			Connectors, couplings	Connectors, couplings		
(1)	Plug	4	PF-M3	KQ2S04-M3G	SMC	Remove the plugs (PF-M3) and install KQ2S04-M3G couplings.
(2)	Coupling	2	UKBL6	-	Koganei Corp.	-
(3)	Connector (FS)	1	HR30-8P-12PC(71)	HR30-8R-12SC(31)	Hirose Electric Co., Ltd.	Cap installed on robot (HR30-8P-C(31))
(4)	Connector (HND)	1	M12 connector / 8P / A Code / Female	M12 connector / 8P / A Code / Male	Tyco Electronics Japan G.K. (TE connectivity)	Cap installed on robot (2823064)
(5)	Connector (LAN)	1	M12 connector / 8P / X Code / Male	M12 connector / 8P / X Code / Female	Tyco Electronics Japan G.K. (TE connectivity)	Cap installed on robot (T4104000000000)
(6)	Connector	1	M12 connector / 8P / A Code / Female	M12 connector / 8P / A Code / Male	Tyco Electronics Japan G.K. (TE connectivity)	Cap installed on robot (2823064)
(7)	Connector (LAN)	1	M12 connector / 8P / X Code / Female	M12 connector / 8P / X Code / Male	Tyco Electronics Japan G.K. (TE connectivity)	Cap installed on robot (2823064)
(8)	Connector (FS)	1	HR30-8R-12SC(31)	HR30-8P-12PC(71)	Hirose Electric Co., Ltd.	Cap installed on robot (HR30-7R-C(31))

2.5.2 Internal wiring and piping

(1) Internal pneumatic plumbing

- 1) Primary plumbing consists of two $\phi 6$ air hoses that run internally from the air inlet port at the base of the robot to the interior of the base.
The ends of the air hoses connect internally to two $\phi 6$ couplings on the side of the robot base. The ends of the $\phi 6$ air hoses are located inside the robot base.
- 2) Secondary plumbing consists of four $\phi 4$ air hoses that run internally from the base of the robot to the top of the elbow. The ends of the air hoses at the AIR IN ports are $\phi 4$ in diameter. The air hoses exit out of M3-size holes at the top of the elbow.
- 3) A solenoid valve set with a maximum of two valves can be installed in the base of the robot. For further information on the solenoid valve set, refer to [Page 35, "\(2\) Solenoid valve set"](#).

(2) Internal wiring of the hand I/O cables

- 1) There are two hand inputs and four hand outputs wired to the mechanical interface. The electric hand connector exits the robot through the flange.
- 2) There are four hand outputs wired in the inside of the robot base. There is a connector for the solenoid valve set connected to the end of the cable. The name of the connector is "GR".
- 3) There are six hand inputs on the underside of the forearm. There are connectors connected to the ends of these cables.

(3) Ethernet cable and force sensor wiring

A category 5e Ethernet cable and a force sensor cable (5-conductor with one of conductors used for the frame ground) run internally up to the mechanical interface. There are connectors connected to the ends of these cables.

Allowable current: 0.7A

Allowable voltage: 24V

2.5.3 Wiring and piping system diagram for hand

The numbers 1 to 8 in this diagram correspond with the numbers in [Table 2-8](#).

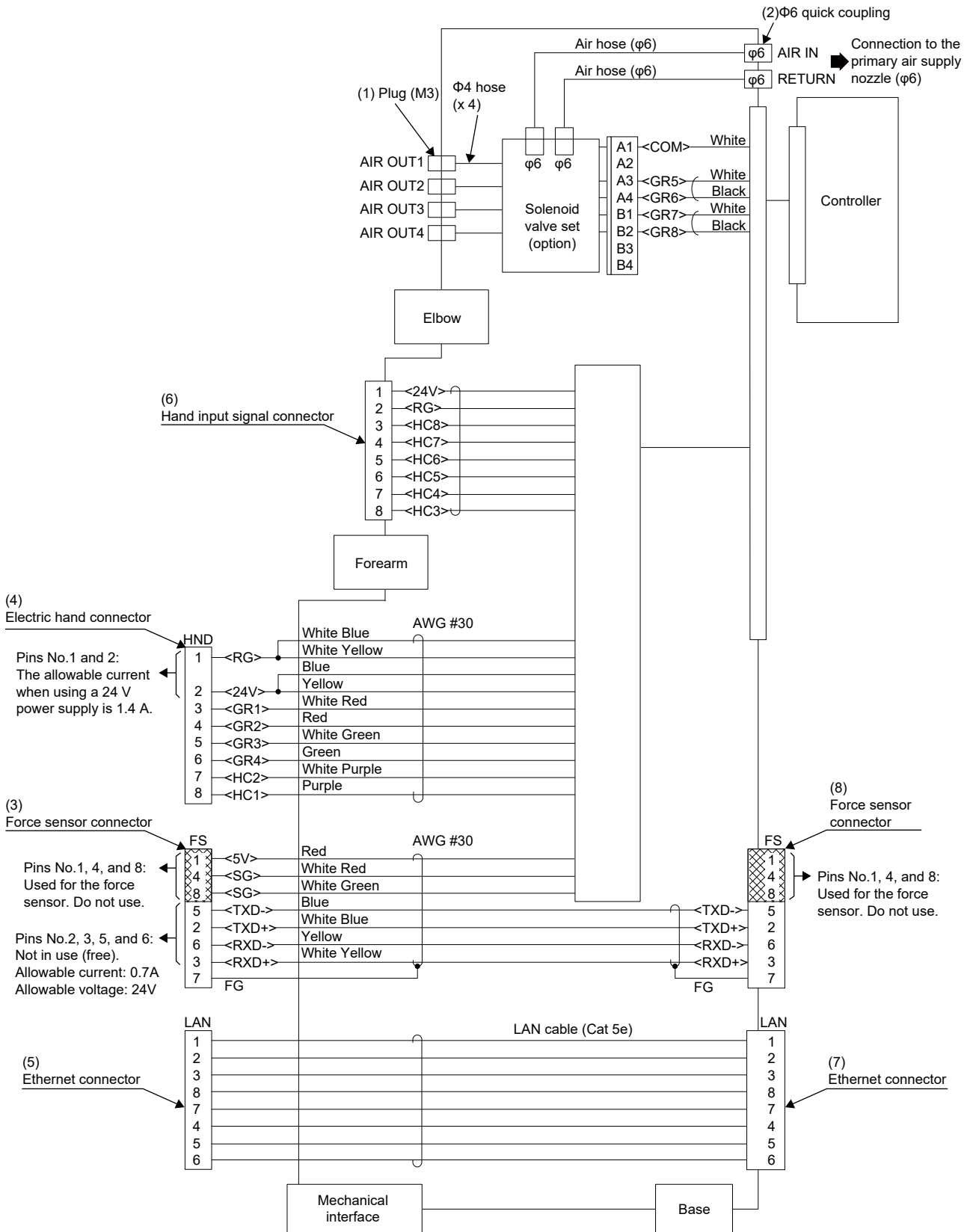

Fig.2-7: Wiring and piping system diagram for hand

2.5.4 Electrical specifications of hand input/output

Table 2-9: Electrical specifications of input circuit

Item		Specifications	Internal circuit
Type		DC input	<p><Sink type></p> <p><Source type></p> <p>* Hand input: HCn=HC1 to HC8 Mechanical interface: HC1 and HC2 Forearm: HC3 to HC8</p>
No. of input points		8	
Insulation method		Photo-coupler insulation	
Rated input voltage		24VDC	
Rated input current		approx.7mA	
Working voltage range		10.2VDC to 26.4VDC (ripple rate within 5%)	
ON voltage/ON current		8VDC or more/2mA or more	
OFF voltage/OFF current		4VDC or less/1mA or less	
Input resistance		Approx. 3.3kΩ	
Response time	OFF-ON	10ms or less (24VDC)	
	ON-OFF	10ms or less (24VDC)	

Table 2-10: Electrical specifications of output circuit

Item		Specifications	Internal circuit
Type		Transistor output	<p><Sink type></p> <p><Source type></p> <p>* Hand output: GRn=GR1 to GR8 Mechanical interface: GR1 to GR4 Base: GR5 to GR8</p>
No. of output points		8	
Insulation method		Digital isolator	
Rated load voltage		24VDC	
Rated load voltage range		21.6VDC to 26.4VDC	
Max. current load		0.1A/ 1 point (100%)	
Current leak with power OFF		0.1mA or less	
Maximum voltage drop with power ON		0.9VDC(TYP.)	
Response time	OFF-ON	2ms or less (hardware response time)	
	ON-OFF	2ms or less (resistance load) (hardware response time)	
Protects		Protects the over-current (0.9A)	

2.5.5 Air supply circuit example for the hand

An example of pneumatic supply circuitry for the hand is shown below.

- 1) Make sure that a surge voltage protection circuit such as a diode is connected to the solenoid coil in parallel.
- 2) When the factory pneumatic pressure drops, as a result of the hand clamp strength weakening, there can be damage to the work. To prevent it, install a pressure switch to the source of the air as shown in Fig. 2-8 and use the circuit described so that the robot stops when pressure drops. Use a hand with a spring-pressure clamp, or a mechanical lock-type hand, that can be used in cases where the pressure switch becomes damaged.
- 3) If the air supply temperature (primary piping) used for the tool etc. is lower than ambient air temperature, the dew condensation may occur on the coupling or the hose surface.

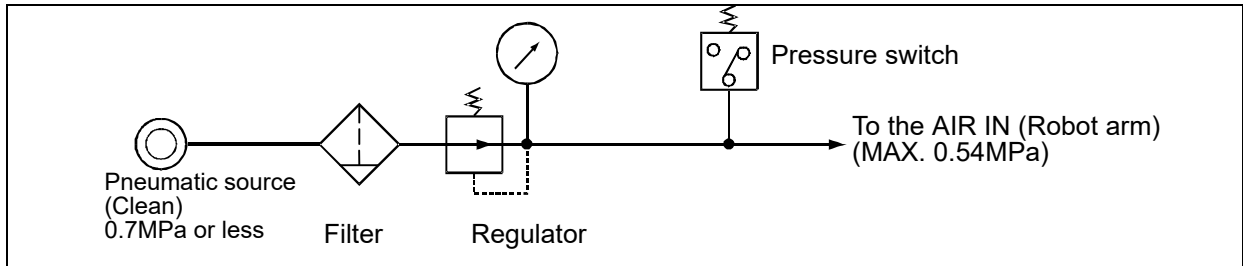

Fig.2-8: Air supply circuit example for the hand

2.5.6 About the Installation of Tooling Wiring and Piping

The customer should supply all wires, hoses, and fixtures for tooling.

Adjust the installation position and the length of wires and hoses to suit the movement of the robot.

After connecting all wires and hoses to the robot, run the robot at low speed and check that the wires and hoses do not interfere with any part of the robot or peripheral devices.

2.6 Options

■What are options?

There are a variety of options for the robot designed to make the setting up process easier for customer needs.

customer installation is required for the options.

(1) Machine cable (replacement)

■ Order type: • Fixed type: 1F-□□UCBL-41 Note) The numbers in the boxes □□ refer the length.

■ Outline



Replace the enclosed 5 m standard machine cables (fixed type) with these cables to reduce or extend the distance between the controller and the robot arm.

■ Configuration

Table 2-11: Configuration equipment and types

Part name	Type ^{Note1)}	Qty.	Mass (kg) ^{Note2)}	Remarks
Machine cable (replacement): Fixed type	1F-□□UCBL-41	1 cable	2.6 (2 m) 9 (10 m)	2 m or 10 m

Note1) □□ represents the cable length.

Note2) Mass indicates one set.

(2) Solenoid valve set

- Order type: One set: 1F-VD01-01(Sink type)/1F-VD01E-01(Source type)
Two sets: 1F-VD02-01(Sink type)/1F-VD02E-01(Source type)

- Outline



The solenoid valve set is an option that is used for controlling toolings when various toolings, such as the hand, are installed at the end of the arm.

Also, for easy installation of this electromaagnetic set onto the robot, it comes equipped with a manifold, couplings, connectors, among other things.

- Configuration

Table 2-12: Configuration equipment

Part name	Type	Qty.	Mass (kg) Note1)	Remarks
Solenoid valve set (1 sets)	1F-VD01-01/ 1F-VD01E-01	Either one pc.	1.0	The solenoid cable is pre-installed. Two M4 × 30 installation screws are included. The 1F-VD0□-01 is sink type and the 1F-VD0□E-01 is source type.
Solenoid valve set (2 sets)	1F-VD02-01/ 1F-VD02E-01	Either one pc.	1.0	

Note1) Mass indicates one set.

- Specifications

Table 2-13: Valve specifications

Item	Specifications
Number of positions	2
Port	5 ^{Note1)}
Valve function	Double solenoid
Operating fluid	Clean air ^{Note2)}
Operating method	Internal pilot method
Effective sectional area (CV value)	0.64mm ² (0.03)
Oiling	Unnecessary
Operating pressure range	0.1 to 0.7MPa
Response time	15 msec or less at 0.5 MPa
Max. operating frequency	10Hz
Ambient temperature	-10°C to 50°C (non-condensing)

Note1) Couplings of unused solenoid valves must be blocked with plugs. If they are not blocked, supplied air will blow out from the couplings, lowering the air pressure of the solenoid valves being used and making them nonfunctional.

Recommended product: KQ2P-04 plug manufactured by SMC Corp.

Note2)

**CAUTION**

The air to be provided must be clean, i.e., filtered with a mist separator or air filter. Failing to do so may lead to malfunctions.

Table 2-14: Solenoid specifications

Item	Specifications
Method	Built-in fly-wheel diodes with surge protection
Rated coil voltage	24VDC ±10%
Power consumption	0.55W
Surge protection circuit	Diode

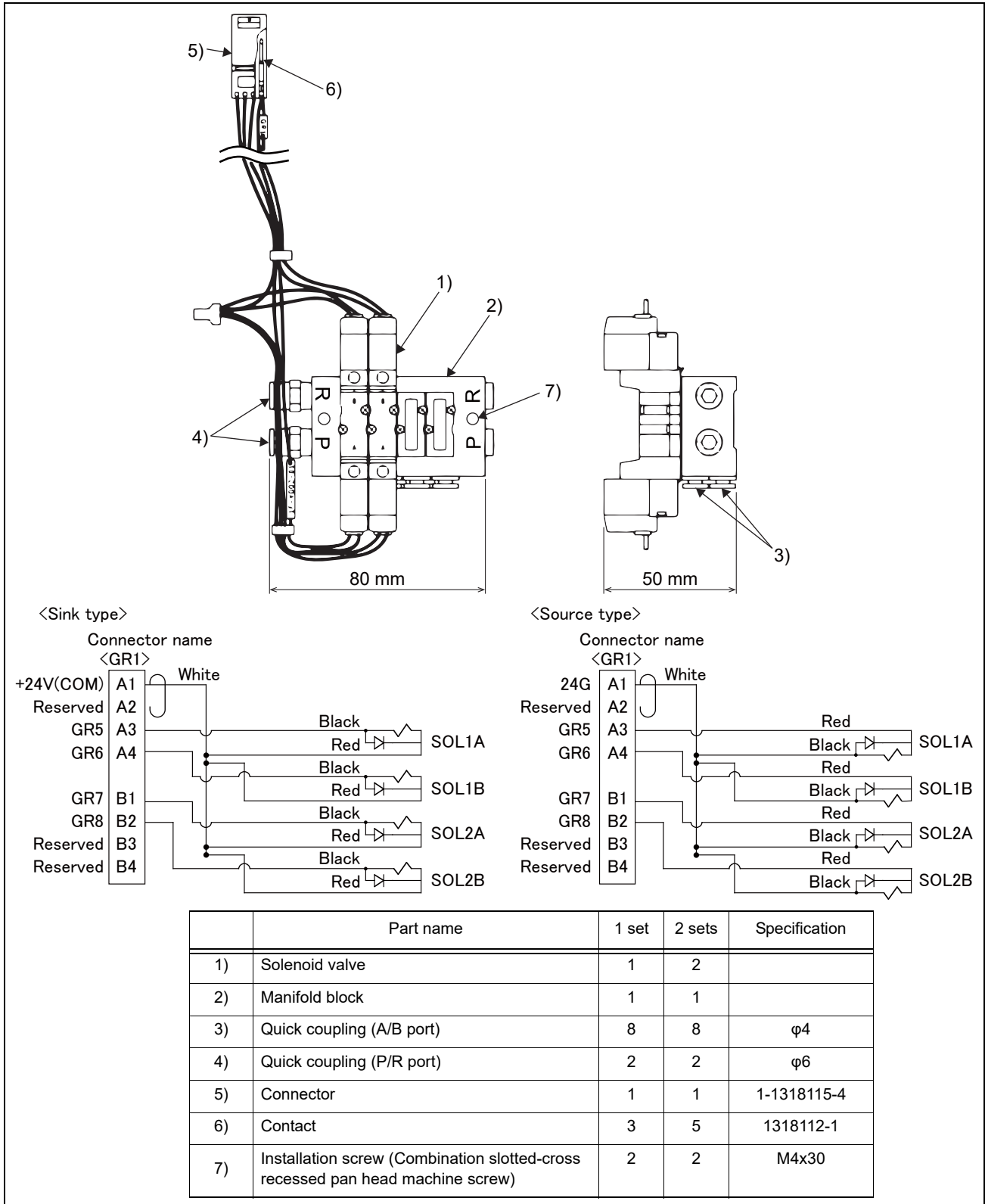
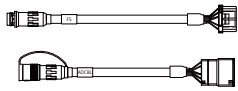

Fig.2-9: Outline dimensional drawing

(3) 2-piece force sensor conversion cable set

■Order type: 1F-ASSISTA-ADCBL

■Outline



This cable set includes a conversion cable for connecting a force sensor to the robot hand and a conversion cable for connecting a force sense interface unit to the base of the robot.

Fig. 2-10 shows the connections of the force sensor set using the cables.

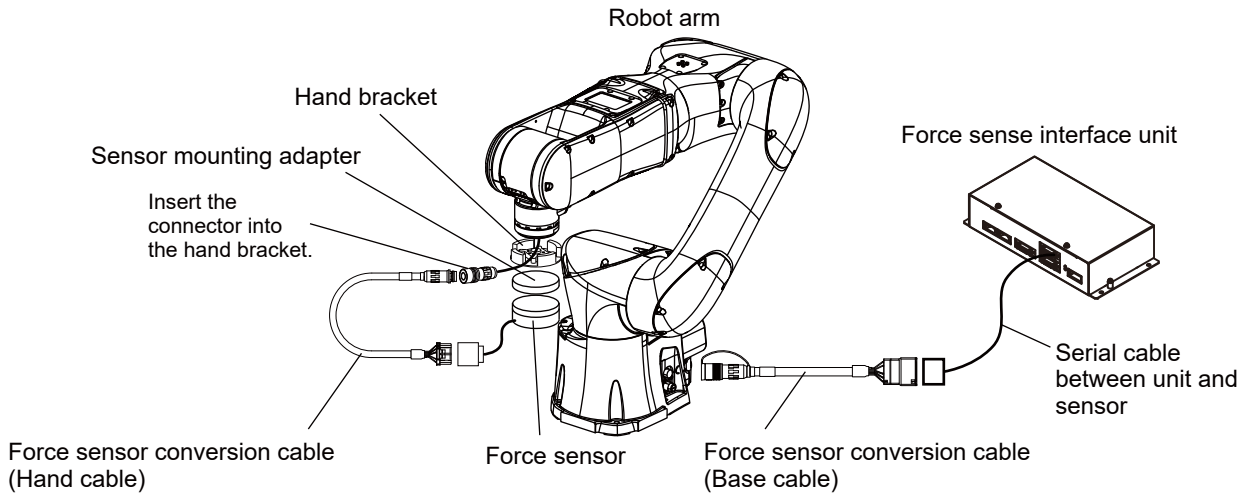

Fig.2-10: Connections of the force sensor set

■Configuration

Table 2-15: Conversion cables

Part name	Type	Qty.	Mass (g) Note1)	Remarks
2-piece force sensor conversion cable set	1F-ASSISTA-ADCBL	1 set	15	This cable set includes two conversion cables. The hand cable is 275 mm in length. The base cable is 200 mm in length.

Note1) The mass of one conversion cable

(4) Vision sensor mounting bracket

■Order type: 1F-ASSISTA-2DVSFLG

■Outline

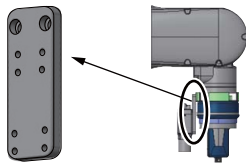

Bracket required to connect a 2D vision sensor to the hand.

Fig. 2-11 shows the mounting of a vision sensor using the bracket.

This product can only be attached to electric hand brackets (manufactured by partner manufacturers). The robot flange does not have mounting screw holes.

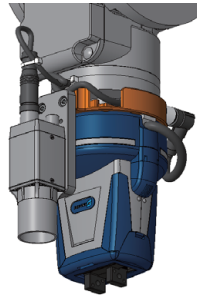
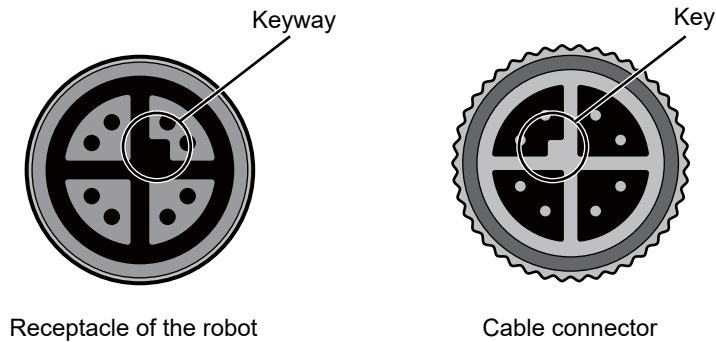

Fig.2-11: Mounting of the vision sensor

CAUTION Align the key of the vision sensor cable connector with the keyway of the receptacle on the robot before connecting the cable.



Receptacle of the robot

Cable connector

■Configuration

Table 2-16: Configuration equipment and types

Part name	Type	Qty.	Mass (g)	Remarks
Vision sensor mounting bracket	1F-ASSISTA-2DVSFLG	1 set	62	-
Vision sensor mounting bracket	-	1 pc.	53	-
Vision sensor mounting screw	-	4 pcs.	3	Hex socket screws, M3 x 6
Positioning pin	-	2 pcs.	2	Parallel pins, φ4 x 10
Screw for mounting brackets	-	2 pcs.	4	Screw with washer, M4 x 12
Cable tie	-	2 pcs.	-	100 mm long

■ Outside dimensions

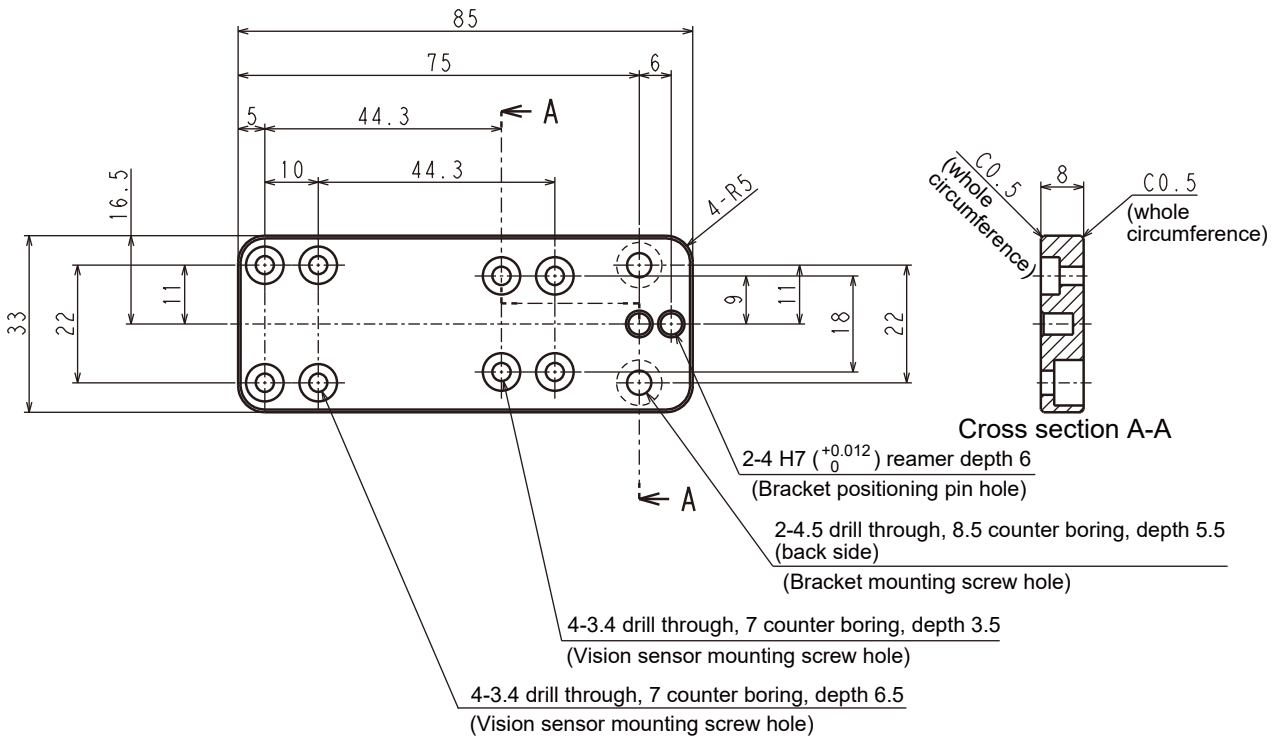

Fig.2-12: Outside dimensions of the vision sensor mounting bracket

2.7 About Overhaul

Robots which have been in operation for an extended period of time can suffer from wear and other forms of deterioration. In regard to such robots, we define overhaul as an operation to replace parts running out of specified service life or other parts which have been damaged, so that the robots may be put back in shape for continued use. As a rule of thumb, it is recommended that overhaul be carried out before the total amount of servo-on time reaches the specified time (36,000 hours for the robot arm and 36,000 hours for the controller). However, the degree of the equipment's wear and deterioration presumably varies depending on their operating conditions. Especially for operation with high load and frequency, the maintenance cycle may be shorter. For details on the part selection for replacement and the timing of overhaul, contact your dealer.

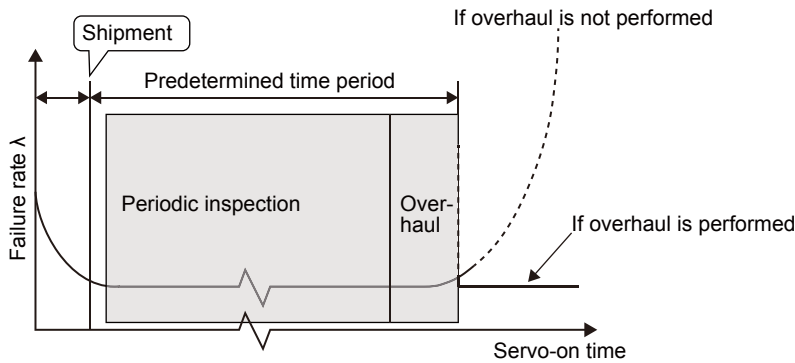

Fig.2-13: Periodic inspection/overhaul periods

2.8 Maintenance parts

As with any other machine, prolonged use of industrial robots causes their parts to wear and degrade, ultimately causing failure. Periodic maintenance and inspection is required to prevent failure and keep the robot running smoothly over long periods of time. For further information on maintenance and inspection, refer to the section "Maintenance and Inspection" in the Robot Arm Setup and Maintenance Instruction Manual.

3 Controller

3.1 Standard specifications

3.1.1 Basic specifications

(1) CR800-05VD controller

Table 3-1: CR800-05VD controller specifications of controller

Item		Unit	Specification	Remarks
Type		-	CR800-05VD	Note1)
Number of control axis		-	Simultaneously 6	-
Memory capacity	Programmed positions	point	39,000	Number of program blocks when using RT VisualBox: 2000 (vision sensor not used), 1800 (vision sensor used) Number of programs: 505 (vision sensor not used), less than 500 (vision sensor used) Note2)
	No. of steps	step	78,000	
	Number of program	-	512	
Robot language		-	MELFA-BASIC VI	-
Teaching method		-	Pose teaching method, MDI method Note3)	-
External input and output	Input/output	point	0/0	Max. 64/64 by option
	Dedicated input/output	-	Assigned with general-purpose input/output	The signal number of "STOP" input signals is fixing.
	Emergency stop input Note4)	point	1 (duplicated)	Note5)
	Emergency stop output	point	1 (duplicated)	
	Mode selector switch input>Note6)	point	1 (duplicated)	
	Mode output	point	1 (duplicated)	
	Robot error output	point	1 (duplicated)	
	Door switch input	point	1 (duplicated)	
	Ecoder input	Channel	2	
Safety I/O		point	8 (duplicated) / 4 (duplicated)	Safety extension unit
Interface	Force sensor interface	Channel	1	-
	Remote input/output	Channel	1	For connection to the Safety extension unit.
	USB	port	1	Ver. 2.0 HighSpeed device functions only. USB mini-B
	Ethernet	port	1	For customer: 1000BASE-T/ 100BASE-TX/10BASE-T
			1	Dedicated T/B port: 100BASE-TX/ 10BASE-T
	Option slot	slot	2	For option interface
	SD memory card slot	slot	1	For extended memory
	RS-422	port	1	Dedicated T/B port
Power source	Input voltage range>Note7)	V	Single phase AC 100 to 120 Single phase AC 200 to 230	The rate of power-supply voltage fluctuation is within 10%.
	Power capacity	kVA	1.0	Does not include rush current. Note8)
	Power supply frequency	Hz	50/60	-
Outline dimensions Note9)		mm	430(W) x 425(D) x 99.5(H)	Excluding protrusions
Mass		kg	Approx. 12.5	-
Construction		-	Self-contained floor type, Opened type. Installation vertically or horizontally	IP20 Note10)
Ambient temperature	In use	°C	0 to 40	Without freeze
	At transport/storage		-15 to +70	
Ambient humidity	In use	%RH	45 to 85	Without dew drops
	At transport/storage		90 or less	

Item	Unit	Specification	Remarks
Overvoltage category ^{Note11)}	-	II or less	-
Pollution level ^{Note12)}	-	2 or less	-
Altitude	m	1000 or less	-
Grounding	Ω	100 or less	100 Ω or less (class D grounding) ^{Note13)}
Paint color	-	Dark gray	Equivalent to Munsell: 3.5PB3.2/0.8, PANTONE: 432C

Note1) Refer to the CR800-D controller Instruction Manual if the CR800-05VD controller is not mentioned in other Instruction Manuals related to this product. For further information refer to [Page 95, "5.1 The details of each instruction manuals"](#) page 81 "5.1 The details of each instruction manuals".

Note2) The maximum number of usable programs differs depending on the number of types of workpieces that are registered.

Note3) Pose teaching method: The method to register the current position of the robot arm.

MDI method: The method to register by inputting the numerical value Immediate.

Note4) Only the STO function can meet the requirements of Category 4, Performance Level e. At factory settings, the STO function meets the requirements of Category 3, Performance Level d. To make the STO function meet the requirements of Category 4, Performance Level e, change the parameter setting by referring to [Page 112, "Appendix 3: Safety diagnosis function \(test pulse diagnosis\)"](#).

Note5) For details on the functions using external input/output signals, always refer to [Page 111, "Appendix 2: Classification of external I/O functions"](#).

Note6) Provide a mode selector switch to change the mode (MANUAL/AUTOMATIC) of the controller. Select the switch that meets the following specifications.

- The switch can be locked in each position of the selected mode.
- The selected switch position can be clearly distinguished from each other.
- Only one mode can be selected at a time.

(Recommended switch model: HA1K-2C2A-2 manufactured by IDEC. The key switch can be locked in each position by removing its key.)

The mode can be changed by other means than the selector switch.

For example, the user can use a mode change program. In the program, provide a means to lock the selected mode with a password.

Note7) This product has undergone EMC testing for products intended for use in industrial environments (tested to standards IEC 61000-6-2 and IEC 61000-6-4). This product is not intended to be connected to residential, commercial, or light-industrial power supplies.

Note8) The power capacity is the recommended value. The power capacity does not include the rush current when the power is turned ON. The power capacity is a guideline and the actual operation is affected by the input power voltage. Use the short circuit breaker which operates by the current leakage under the commercial frequency domain (50-60Hz). If sensitive to the high frequency ingredient, it will become the cause in which below the maximum leak current value carries out the trip.

The following table shows current values for reference.

Input voltage	Item	Current [A]	Apparent power [kVA]	Voltage at measurement [V]	
Single-phase 100 V AC	At control power ON	0.52	0.06	104.3	
	At servo ON	0.52	0.06	104.3	
	In automatic operation	Effective value	3.25	0.36	108.0
		Peak	9.00	1.06	108.6
Single-phase 200 V AC	At control power ON	0.40	0.08	218.5	
	At servo ON	0.84	0.18	218.9	
	In automatic operation	Effective value	2.77	0.62	218.8
		Peak	7.00	1.50	219.5

Note9) Refer to [Page 50, "3.3.1 Outside dimensions"](#) for details.

Note10) This controller is standard specification. (Refer to [Page 46, "3.1.2 Protection specifications and operating supply"](#).)

Note11) This indicates the section of the power supply to which the equipment is assumed to be connected between the public electrical power distribution network and the machinery within premises.

Category II applies to equipment for which electrical power is supplied from fixed facilities. The surge voltage withstand level for up to the rated voltage of 300V is 2500V.

Note12) This index indicates the degree to which conductive material is generated in terms of the environment in which the equipment is used.

Pollution level 2 is when only non-conductive pollution occurs. A temporary conductivity caused by condensing must be expected occasionally.

Note13) The robot must be grounded by the customer.

(2) Safety extension unit

Item		Description	Remarks	
Safety function Note1)	STO function	The function electrically shuts off the driving energy to the motor of the robot arm.	IEC 60204-1 Corresponds to stop category 0	
	SS1 function	The function to control and decelerate the motor speeds of the robot. After stopping, the robot transitions to the STO state.	IEC 60204-1 Corresponds to stop category 1	
	SS2 function	The function to control and decelerate the motor speeds of the robot. After stopping, the robot transitions to the SOS state.	IEC 60204-1 Corresponds to stop category 2	
	SOS function	Without shutting off the driving energy to the motors, this function monitors the robot so that it stays at rest.	When SOS, SLS, SLP, and STR detect error, activate SS1. EN 61800-5-2 compliant	
	SLS function	This is a function to monitor each part of the robot arm so that their speeds do not exceed monitoring speeds.		
	SLP function	The function monitors specified monitoring positions so that they do not go across position monitoring planes.		
	STR function	This function ensures that the torque limits of each motor in the robot are not exceeded.		
Safety performance	Standard	EN ISO 10218-1: 2011 ISO/TS 15066: 2016 EN ISO 13849-1: 2015 IEC 61800-5-1: 2007 EN 61800-5-2: 2017 EN 61000-6-7: 2015 EN 61326-3-1: 2017 IEC 61508-1: 2010 IEC 61508-2: 2010 IEC 61508-3: 2010 EN 62061: 2005/A2: 2015 IEC 62061: 2005/AMD1: 2012/AMD2: 2015	-	
	Performance Note2)	STO	SIL2, PLd/Category 3 (at factory settings) SIL3, PLe/Category 4 (with changes to parameters) Note3)	-
		SS1,SOS,SS2, SLS,SLP, STR	SIL 2, PLd/Category 3	-
	Dangerous failure rate Note4)	STO	PFH = 1.40×10^{-8} [1/h]	-
		SS1,SS2,SOS	PFH = 3.42×10^{-7} [1/h]	-
		SLS	PFH = 3.42×10^{-7} [1/h]	-
		SLP	PFH = 3.42×10^{-7} [1/h]	-
		STR	PFH = 3.62×10^{-7} [1/h]	-

Item		Description	Remarks	
Safety extension unit	Power supply specifications	Voltage	24 V DC±5% Ripple 0.2 V (P-P)	Supplied by customer
		Maximum consumption current	300 mA	-
	Structure (IP rating)		IP20	-
	Weight		0.8kg	-
	Environment	Operating temperature range	0 to 40°C	It must be kept away from heat appliances and other heat sources.
		Relative humidity	45 to 75%	Non-condensing
		Vibration	During transportation 3.5 G During operation: 0.5 G or less	-
		Atmosphere	No corrosive gas / flammable gas / oil mist/dust	-
		Installation environment	Indoors Place where no intense electromagnetic energy is generated No roughness or tilt on the installation surface	No direct sunlight. Do not install the unit on very rough surfaces.
	Input signal		8 routes (duplicated signal)	-
	Output signal		4 routes (duplicated signal)	-

Note1) The safety functions conform to EN 61800-5-2.

Note2) Safety performance of this product complies with IEC/EN 61508 and EN ISO13849-1.

Note3) To use this product at a performance level of Category 4, Performance Level e, refer to [Page 112](#), "Appendix 3: Safety diagnosis function (test pulse diagnosis)" and set the parameters accordingly.

Note4) The robot controller PFH or PFHd (Probability of Dangerous Failure per Hour). The PFH of the emergency stop switch and enable switch on the teaching pendant is shown in the table below.

Switch	Model No. / manufacturer	B10d [cycle]	n_{op} [cycle/year]	MTTFd [year]	DC [%]	PFH [1/hour]
Emergency stop switch	AB6E-3BV02PTRM /IDEC	1×10^6	6000	1667	99	2.47×10^{-8}
Enable switch	HE5B-M2PY /IDEC	1×10^6	6000	1667	99	2.47×10^{-8}

PFH as described in Table K of ISO 13849-1: 2015.

E.g.) If the teaching pendant emergency stop switch is used with the controller's SS1 function enabled, the PFH of the system will be $2.47 \times 10^{-8} + 3.42 \times 10^{-7} = 3.67 \times 10^{-7}$ (PL = d).

For systems using the I/O signals of the safety extension unit, add the PFH value in the table below. Safety performance of the safety extension unit complies with PLd/Category 3.

MTTFd [year]	DC [%]	PFH [1/hour]
318	90	2.41×10^{-8}

3.1.2 Protection specifications and operating supply

(1) Protection specifications

A protection method complying with the IEC Standard IP20 (Opened type) is adopted for CR800 controller.

The IEC IP symbols refer only to the degree of protection between the solid and the fluids, and don't indicated that any special protection has been constructed for the prevention against oil and water.

[Information]

- The IEC IP20

It indicates the protective structure that prevents an iron ball 12 ± 0.05 mm diameter, which is being pressed with the power of $3.1 \text{ kg} \pm 10\%$, from going through the opening in the outer sheath of the supplied equipment.

(2) Operating supply

The controller is supposed to be installed and used in the customer's system. Supply the primary power of the controller from the system. In addition, provide a safety device (ex. earth leakage breaker) that can shut off the power of the controller in the customer's system. When using an earth leakage breaker as a safety device, select a product with the highest sensitivity possible referring to the specifications in the table below.

Item	Unit	Specification
Rated voltage	V	AC100 to 120, AC200 to 230
Rated sensitivity current	mA	30 or more, but as low as possible
Rated current	A	10 or more, but as low as possible

Refer to the section [Page 106, "6.2 Working environment"](#) for details on the working environment.

3.2 Names of each part

3.2.1 CR800-05VD controller

Controller front

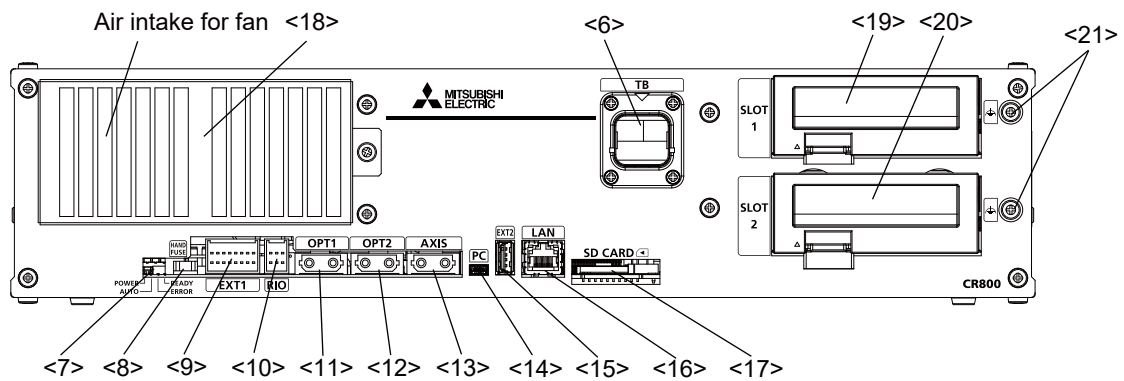

Controller rear

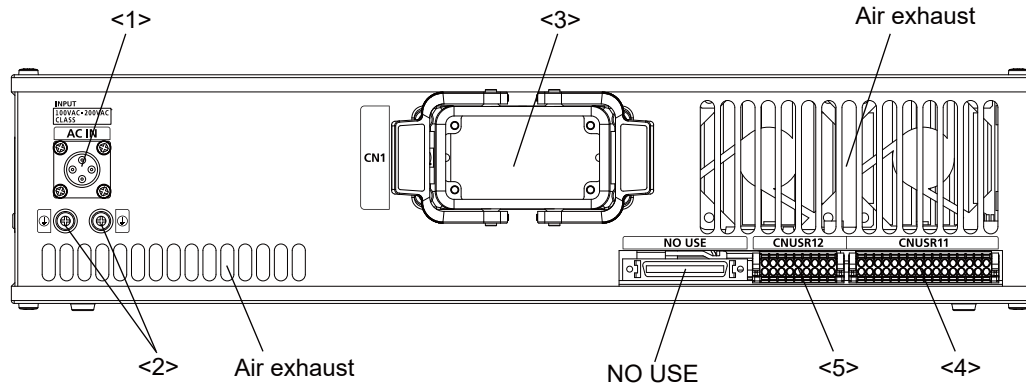

Fig.3-1: Names of controller parts

<1> ACIN connector.....Socket used to connect the supplied ACIN cable (input voltage: 100 V AC/200 V AC)
Refer to a separate manual “INSTRUCTION MANUAL/Controller Setup and Maintenance” for how to connect a power cable.

Number of phase	ACIN cable
Single phase	<p>Terminal: M5, cable length: 3m</p>

<2> PE terminalTerminals for grounding (M4 screw x 2).

<3> CN1 cableMachine cable connector.

<4> <5> CNUSR connectorRobot I/O cable connectors.

<4>: CNUSR11, <5>: CNUSR12

Refer to a separate manual “INSTRUCTION MANUAL/Controller Setup and Maintenance” for the connection method and the further description of pin assignment.

<6> TB connector.....Dedicated connector for connecting T/B.

<7> LED Four LEDs indicating the controller status.

LED	Details
POWER	Indicates the control power status. On: Control power ON Off: Control power OFF
AUTO	Indicates the controller mode. On: AUTOMATIC mode Off: MANUAL mode
ERROR	Indicates the error status. On: Error occurred. Rapid flashing: High-level error occurred. Off: Normal operation
READY	Indicates the operation status. On: ON (ready) Slow flashing: During operation Rapid flashing: Operation suspended.

<8> HAND FUSE Fuse for the hand.

<9> EXT1 Connector for releasing the brake in an emergency.
For details on the method of releasing the brake in an emergency, refer to the separate manual, "INSTRUCTION MANUAL/Robot Arm Setup and Maintenance".

Port used to connect the safety extension unit

<10> RIO Parallel I/O extension connector.

<11> OPT1 Unused.

<12> OPT2 Unused.

<13> AXIS Port used to connect the force sensor

<14> PC Connector for communication with a personal computer.

<15> EXT2 Connector for function extension.

<16> LAN Connector for Ethernet communication.

<17> SD CARD SD memory card slot.

<18> Filter cover Dustproof dust filter cover. An air filter is provided inside the filter cover.

<19> <20>Option slot..... Option card slots (must be covered when not used).

<19> SLOT1, <20> SLOT2

<21> FG terminal Option card cable terminals for grounding (M4 screw x 2).

Caution

Use the network equipments (personal computer, USB hub, LAN hub, etc) confirmed by manufacturer. The thing unsuitable for the FA environment (related with conformity, temperature or noise) exists in the equipments connected to USB. When using network equipment, measures against the noise, such as measures against EMI and the addition of the ferrite core, may be necessary. Please fully confirm the operation by customer. Guarantee and maintenance of the equipment on the market (usual office automation equipment) cannot be performed.

3.2.2 Safety extension unit

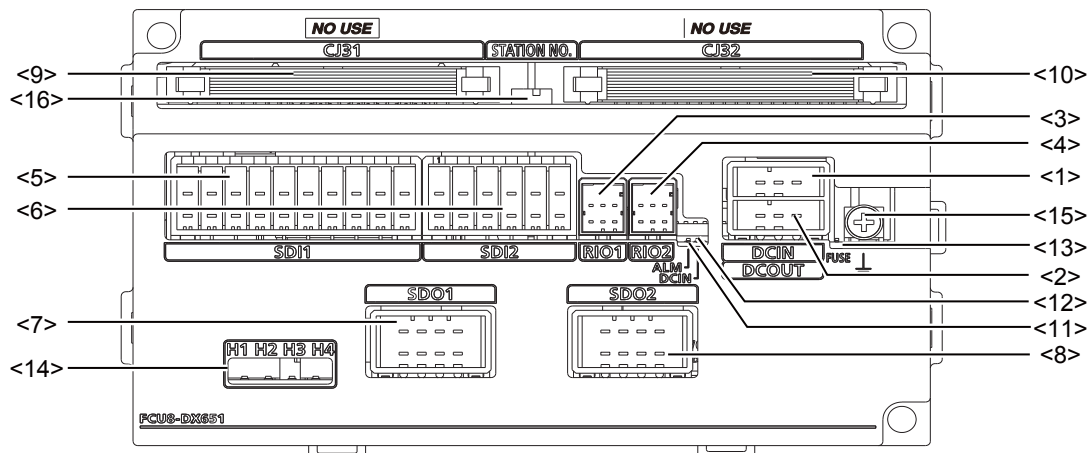

Fig.3-2: Names of safety extension unit parts

- <1> DCIN connectorSocket used to connect the supplied DCIN cable (input voltage: 24 VDC)
- <2> DCOUT connectorUnused.
- <3> RIO1connector.....Port used to connect the robot controller.
- <4> RIO2 connector.....Unused. Connect the supplied terminator cap (2F-SFTM).
- <5> SDI1 connectorSafety DI input port
- <6> SDI2 connectorSafety DI input port
- <7> SDO1 connectorSafety relay output port
- <8> SDO2 connectorSafety relay output port
- <9> CJ31 connector.....Unused.
- <10> CJ32 RIOUnused.
- <11> ALM LEDThis LED indicates remote I/O communication status. On: Error / Off: Normal operation
- <12> DCIN LEDThis LED indicates the status of the 24 VDC power supply. On: Normal operation / Off: Error
- <13> FUSE LEDThis LED indicates the status of the fuse. On: Normal operation / Off: Fuse blown
- <14> H1, H2, H3, H4 LEDThis LED indicates the status of the relay. On: Normal operation / Off: Relay welded shut
- <15> FG terminalThis is the terminal used to ground the safety extension unit. (M4 × 1)
- <16> STATION NO. switchStation number switch. Set to Station number setting 2 from the factory. Do not change.

3.3 Outside dimensions/Installation dimensions

3.3.1 Outside dimensions

(1) CR800-05VD controller

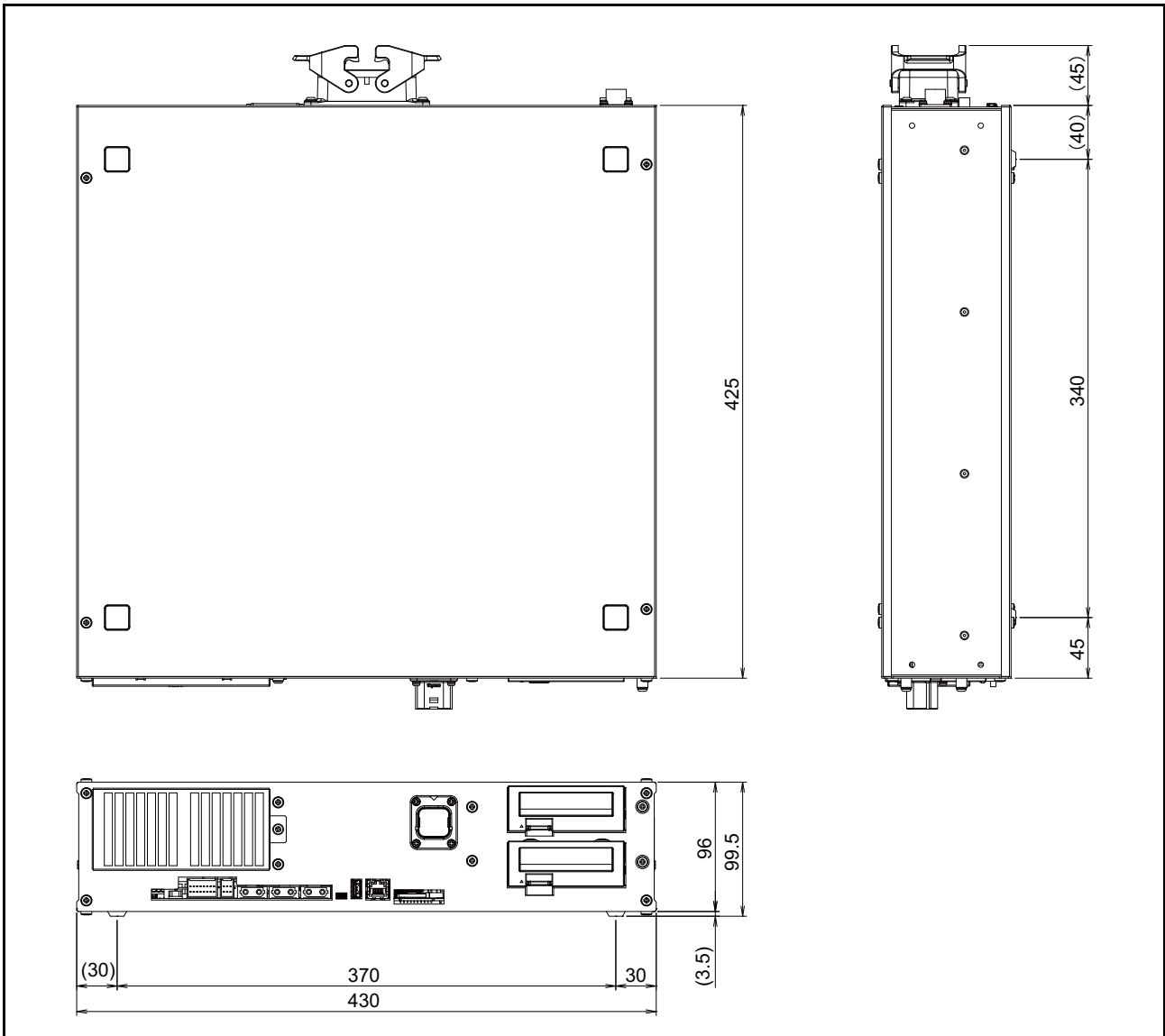

Fig.3-3: Outside dimensions of controller

Warning labels and rating plate

	<p>注意</p> <p>1) 外部緊急停止スイッチ[1]、ドアスイッチ[2]、セレクタスイッチ[3]が開放状態にあることを確認して適切な配線を行ってください。入力端子[1]と[2]が開放状態にある場合、エラーが発生します。</p> <p>2) コンローラの搬送時には両側から吊るす必要があります。吊るす位置がずれれば落下の恐れがあります。</p> <p>3) 天板の取り外しは動作中の電源を遮断し、少なくとも3分間電源をオフにしてください。電源が再接続されるまで電源をオフにしないでください。電源が再接続されると電気ショックの恐れがあります。</p> <p>4) 自動運転中に電源をオフしないで行くと、自動運転プログラムがバックアップされず、電源が再接続されるとエラーが発生します。</p> <p>5) 漏電防止ブレーカを接続する際は、漏電防止ブレーカを電源供給に接続してください。</p> <p>6) オプションカードの取り付け時にSLOT1、SLOT2のオプションカードを取り付ける必要があります。</p> <p>7) 自動運転中にコンローラのトップパネルを取り外す場合は、少なくとも5秒間セレクタスイッチを3番位置に軽く引っ掛ける必要があります。スイッチが完全に引っ掛かるまで引っ掛ける必要があります。</p> <p>8) IP20の保護等級は適用範囲外です。コンローラの保護等級はIP20に相当します。</p>	<p>CAUTION</p> <p>1) The input terminal of Emergency stop switch [1], Door switch [2], and Selector switch [3] is open (unconnected). Ensure appropriate wiring for use. When the input terminal of [1] and [2] is open, an error occurs.</p> <p>2) Hold the bottom of the controller on both sides for transportation. Failure to do so could result in dropping.</p> <p>3) Wait at least 3 minutes after turning the power off before removing the top panel. Do not turn the power on until the top panel has been installed. Failure to do so could result in electric shock.</p> <p>4) Do not turn the power off during the automatic running. Save the robot program for backup.</p> <p>5) Use an Earth Leakage Breaker for connecting the power supply to prevent electric shock.</p> <p>6) The cover of SLOT1 and SLOT2 must be installed when the option card is not used.</p> <p>7) To remove the T/B from the controller during automatic operation, pull out the T/B connector within five seconds while the 3-position enable switch of the T/B is being pulled up lightly (in the position 2). While the switch is being pulled up all the way (in the position 3), the robot stops.</p> <p>8) Protection rating of the controller corresponds to IP20.</p>	<p>VORSICHT</p> <p>1) Der Eingangsanschluss für den Notstop [1], den Türschalter [2] und den Wählschalter [3] ist offen (unangeschlossen). Stellen Sie sicher, dass die Verkabelung ordnungsgemäß erfolgt. Wenn der Eingangsanschluss von [1] und [2] offen ist, tritt ein Fehler auf.</p> <p>2) Halten Sie den Controller auf beiden Seiten beim Transport. Wenn die Unterseite nicht richtig gehalten wird, kann das Gerät fallen.</p> <p>3) Warten Sie nach dem Ausschalten mindestens 3 Minuten, bevor Sie die Abdeckung entfernen. Schalten Sie den Strom nicht wieder ein, bevor die Abdeckung montiert ist. Wenn die Abdeckung ohne Anweisung fern bleibt, kann dies zu elektrischen Schlagrisiken führen.</p> <p>4) Entfernen Sie den Strom während des automatischen Laufens nicht. Speichern Sie das Roboterprogramm als Backup.</p> <p>5) Verwenden Sie für den Stromanschluss einen Erdschlussfehler-Schutz, um einen elektrischen Schlag zu vermeiden.</p> <p>6) Wenn die optionale Karte nicht verwendet wird, müssen die Abdeckungen der SLOT1 und SLOT2 montiert werden.</p> <p>7) Um die T/B während des automatischen Betriebs vom Controller zu entfernen, ziehen Sie den T/B-Anschluss nach fünf Sekunden heraus, während die 3-Stellungsfäherschalter des T/B leicht nach oben gezogen wird (in Position 2). Sobald der Schalter vollständig nach oben gezogen wird (in Position 3), wird der Roboter gestoppt.</p> <p>8) Die Controller-Version ist Schutzklasse IP20.</p>	<p>注意</p> <p>外部緊急停止スイッチ[1]、ドアスイッチ[2]、セレクタスイッチ[3]が開放状態にあることを確認して適切な配線を行ってください。入力端子[1]と[2]が開放状態にある場合、エラーが発生します。</p> <p>搬送時は、両側から吊るす必要があります。</p> <p>天板の取り外しは動作中の電源を遮断し、少なくとも3分間電源をオフにしてください。電源が再接続されるまで電源をオフにしないでください。電源が再接続されると電気ショックの恐れがあります。</p> <p>自動運転中に電源をオフしないで行くと、自動運転プログラムがバックアップされず、電源が再接続されるとエラーが発生します。</p> <p>漏電防止ブレーカを接続する際は、漏電防止ブレーカを電源供給に接続してください。</p> <p>オプションカードの取り付け時にSLOT1、SLOT2のオプションカードを取り付ける必要があります。</p> <p>自動運転中にコンローラのトップパネルを取り外す場合は、少なくとも5秒間セレクタスイッチを3番位置に軽く引っ掛ける必要があります。スイッチが完全に引っ掛かるまで引っ掛ける必要があります。</p> <p>IP20の保護等級は適用範囲外です。</p>	<p>주의</p> <p>외부 긴급 정지 스위치 [1], 도어 스위치 [2], 셀렉터 스위치 [3]가 개방 상태에 있는지 확인하고 적절한 배선을 하십시오. 입력 터미널 [1]과 [2]가 개방 상태에 있으면, 오류가 발생합니다.</p> <p>운송 시 양면에서 천장을 이용해 운반하십시오. 그렇지 않으면 낙하할 수 있습니다.</p> <p>상판 제거 시 동작 중인 전원 차단 후 최소 3분 이상 전원을 차단하십시오. 전원이再接속될 때까지 상판을 제거하지 마십시오.</p> <p>자동 운전 중에 전원을 끄지 마십시오. 자동 운전 프로그램을 백업하십시오.</p> <p>전원 공급을 연결할 때는 누전 차단기를 사용하여 전기 충격 예방하십시오.</p> <p>선택 옵션 카드가 사용되지 않을 때는 SLOT1과 SLOT2 덮개도 설치하십시오.</p> <p>자동 운전 중에 T/B를 컨트롤러에서 분리하려면, T/B 커넥터를 최소 5초 동안 3번 위치로 가볍게 당기십시오. 스위치가 완전히 당겨지는 동안(3번 위치), 로봇이 정지합니다.</p> <p>IP20의 보호 등급은 적용 범위를 벗어납니다.</p>	<p>外部緊急停止スイッチ[1]、ドアスイッチ[2]、セレクタスイッチ[3]が開放状態にあることを確認して適切な配線を行ってください。入力端子[1]と[2]が開放状態にある場合、エラーが発生します。</p> <p>The input terminal of Emergency stop switch [1], Door switch [2], and Selector switch [3] is open (unconnected). Ensure appropriate wiring for use. When the input terminal of [1] and [2] is open, an error occurs.</p> <p>Der Eingangsanschluss für den Notstop [1], den Türschalter [2] und den Wählschalter [3] ist geöffnet (nicht angeschlossen). Stellen Sie sicher, dass die Verkabelung ordnungsgemäß erfolgt. Wenn der Eingangsanschluss von [1] und [2] offen ist, tritt ein Fehler auf.</p> <p>Wenn der Eingangsanschluss von [1] und [2] offen ist, tritt ein Fehler auf.</p> <p>内部緊急停止スイッチ[1]、ドアスイッチ[2]、セレクタスイッチ[3]の投入端子開放状態を確認して適切な配線を行ってください。入力端子[1]と[2]が開放状態にある場合、エラーが発生します。</p> <p>図3-4の接続図を参照してください。</p> <p>cNCi371 Input terminal connection wiring drawings</p>
--	---	--	---	--	---	---

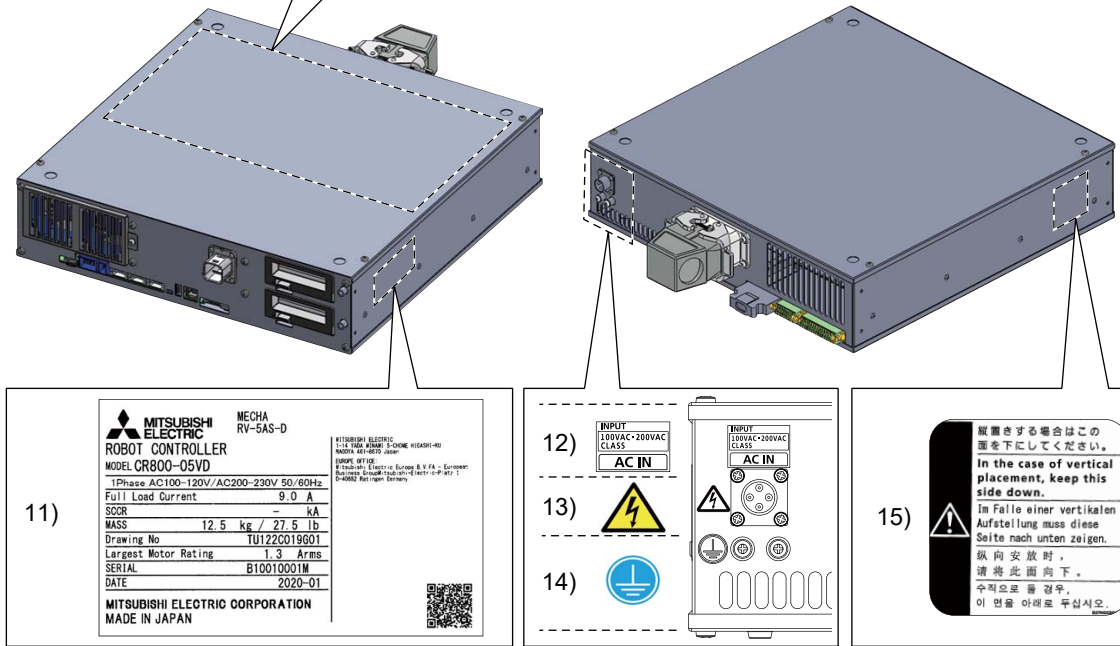

Fig.3-4: Location of the warning labels and rating plate

Table 3-2: Details of the warning labels and rating plate

No.	Description	Details
1)	External emergency stop switch, door switch, and selector switch	The input terminal of Emergency stop switch [1], Door switch [2], and Selector switch [3] is open (unconnected). Ensure appropriate wiring for use. When the input terminal of [1] and [2] is open, an error occurs.
2)	Transportation of the robot controller	Hold the bottom of the controller on both sides for transportation. Failure to do so could result in dropping.
3)	Precautions when removing the top panel	Wait at least 3 minutes after turning the power off before removing the top panel. Do not turn the power on until the top panel has been installed. Failure to do so could result in electric shock.
4)	Precautions during automatic operation	Do not turn the power off during the automatic running. Save the robot program for backup.
5)	Connection of an earth leakage breaker	Use an Earth Leakage Breaker for connecting the power supply to prevent electric shock.
6)	Optional cover	The cover of SLOT1 and SLOT2 must be installed when the option card is not used.
7)	Removal of the teaching pendant	To remove the T/B from the controller during automatic operation, pull out the T/B connector within five seconds while the 3-position enable switch of the T/B is being pulled up lightly (in the position 2). While the switch is being pulled up all the way (in the position 3), the robot stops.

No.	Description	Details
8)	IP rating of the robot controller	IP20 Protection rating of the controller corresponds to IP20.
9)	External emergency stop switch, door switch, and selector switch	The input terminal of Emergency stop switch [1], Door switch [2], and Selector switch [3] is open (unconnected). Ensure appropriate wiring for use. When the input terminal of [1] and [2] is open, an error occurs.
10)	CNUSR11 input terminal connector array drawing	<p style="text-align: center;">< CNUSR11 入力端子コネクタ配列図 > < CNUSR11 input terminal connector array drawing ></p> <p style="text-align: center;"> セレクタスイッチ2 ドアスイッチ2 外部非常停止2 セレクタスイッチ1 ドアスイッチ1 外部非常停止1 Selector switch 2 Door switch 2 Emergency stop switch 2 Selector switch 1 Door switch 1 Emergency stop switch 1 </p>
11)	Rating plate	<p>Robot controller model</p> <p>Input voltage range and power supply frequency</p> <p>Maximum load current</p> <p>Short-circuit current rating</p> <p>Mass (kg/lb)</p> <p>Drawing No.</p> <p>Maximum motor rating</p> <p>Serial No.</p> <p>Date of manufacture</p> <div style="border: 1px solid black; padding: 5px; margin-top: 10px;"> MECHA RV-5AS-D ROBOT CONTROLLER MODEL CR800-05VD 1Phase AC100-120V/AC200-230V 50/60Hz Full Load Current 9.0 A SCOR - kA MASS 12.5 kg / 27.5 lb Drawing No TU122C019G01 Largest Motor Rating 1.3 Arms SERIAL B10010001M DATE 2020-01 MITSUBISHI ELECTRIC CORPORATION MADE IN JAPAN </div> <div style="margin-top: 10px; text-align: right; font-size: small;"> MITSUBISHI ELECTRIC 1-1-1 YOKOYAMA 5-CHOME HIRAKAWA-KU NAGOYA 461-8670 JAPAN EUROPE OFFICE Mitsubishi Electric Europe B.V. FA - European Business Group Mitsubishi Electric Platz 1 D-40882 Ratingen Germany </div>
12)	Input	<div style="border: 1px solid black; padding: 5px; width: fit-content; margin: auto;"> INPUT 100VAC-200VAC CLASS AC IN </div>
13)	Electric shock risk sign	
14)	Protective earth symbol	
15)	Precautions for vertical installation	In the case of vertical placement, keep this side down.

(2) Safety extension unit

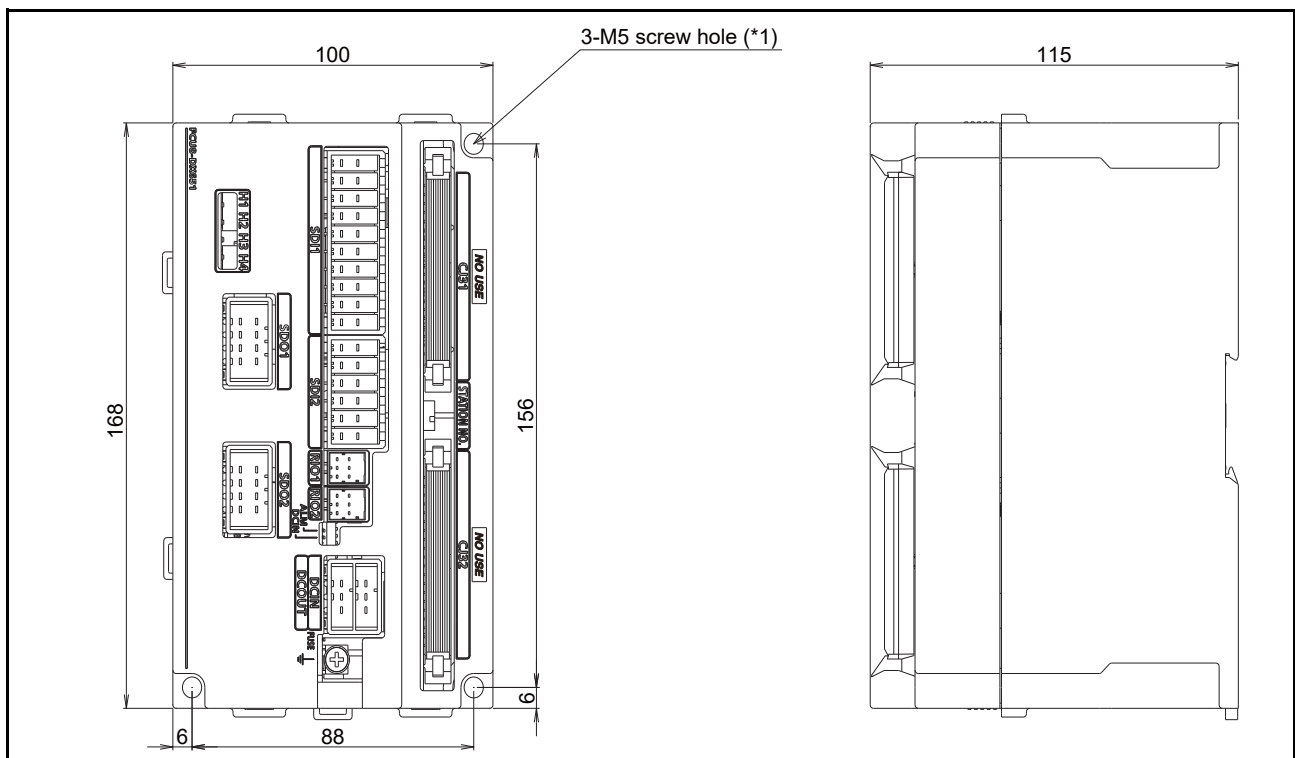

Fig.3-5: Safety extension unit external dimensions

Fix the safety extension unit in place using either of the following:

- The holes indicated by "*"1" in the diagram above
- A DIN rail located in an area that is free of vibration

3.3.2 Installation dimensions

The following figures show the dimensions required installing the controller.
 For the placement of the controller on its side (the horizontal installation), two stacks is permitted.

Horizontal installation

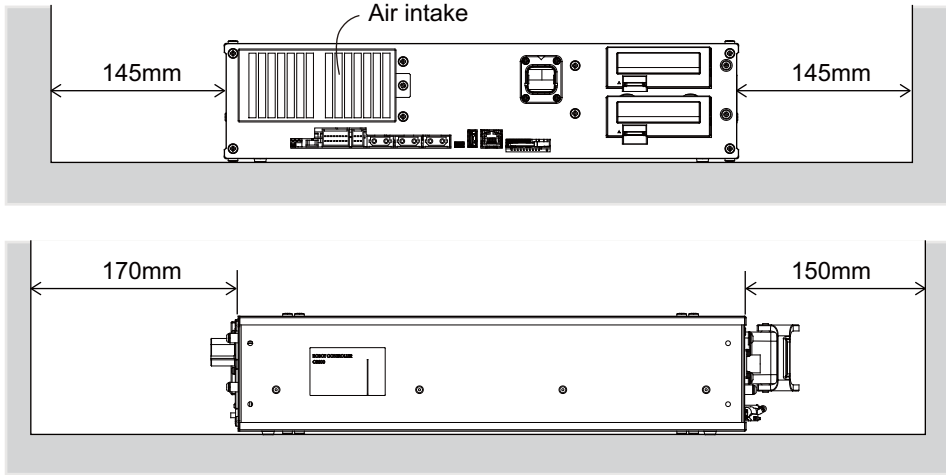

Vertical installation

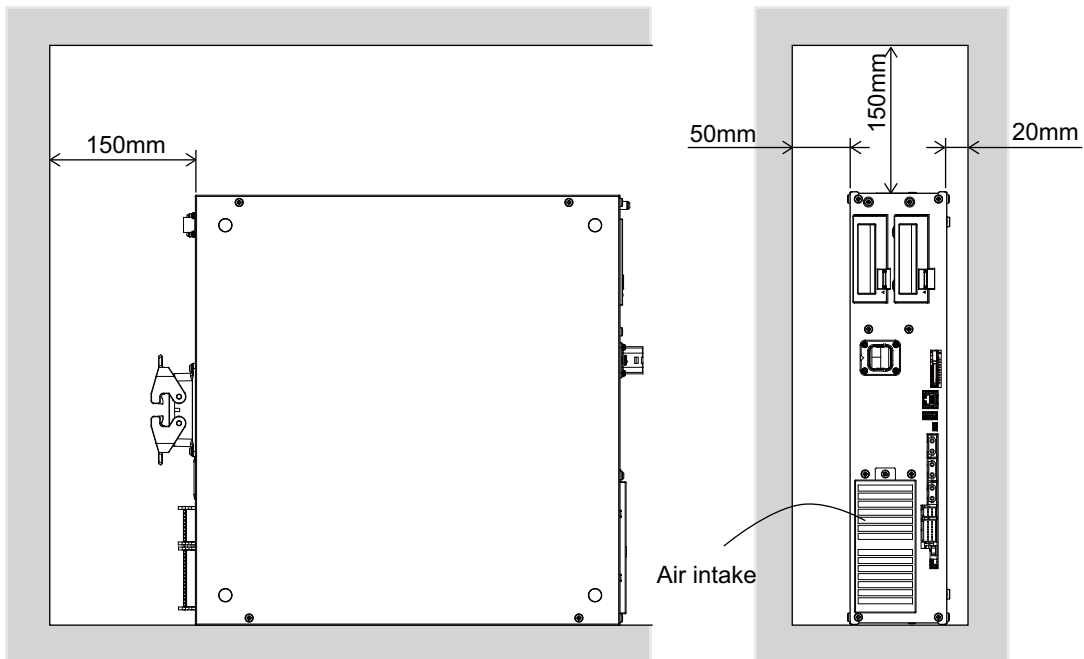

Fig.3-6: Installation dimensions

CAUTION When installing the controller vertically, ensure that the air intake is at the bottom as illustrated in Fig. 3-6.

CAUTION Fixing installation section sure for prevention from the fall, when using the controller placing vertically. The reference figure of the metal plate for fixing is shown in Fig. 3-7.

You should install the metal plate for fixation to the controller with M4 x 8 or the shorter screw. The screw projection length inside the controller (side board thickness is 1.2 mm) surely makes 6.8 mm or less.

⚠ CAUTION

When storing the controller in a cabinet, etc., take special care to the heat radiating properties and ventilation properties so that the ambient temperature remains within the specification values. And, don't install the controller in the position where direct rays or the heat of lighting hits. The skin temperature of the controller may rise, and the error may occur.

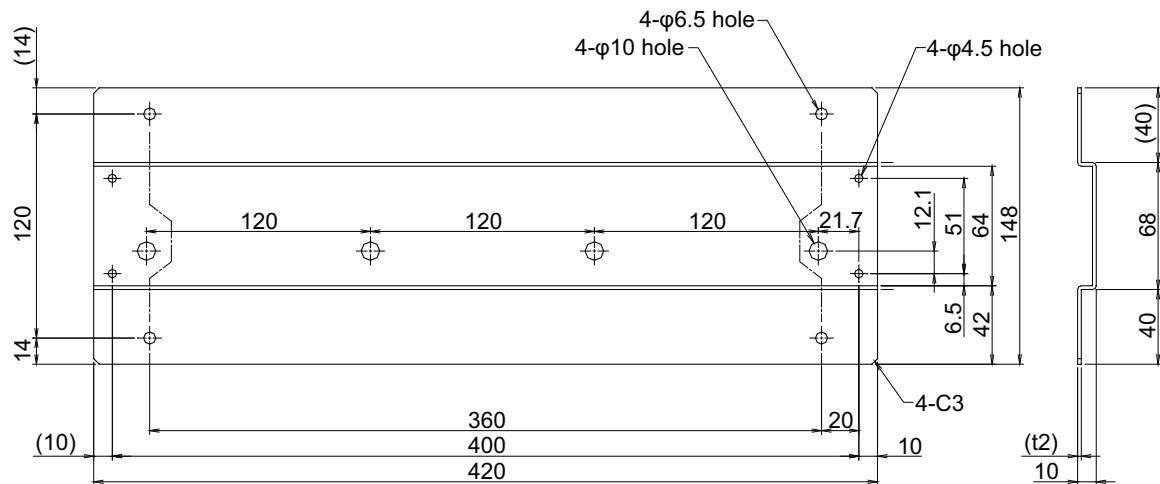

Fig.3-7: Reference figure of the fixing metal plate for vertical installation

3.4 External input/output

3.4.1 Types

- (1) Dedicated input/output..... These inputs and outputs carry out the robot remote operation and status display.
- (2) General-purpose input/output..... These are inputs and outputs that the customer can program for peripheral device control.
- (3) Hand input/output These are inputs and outputs related to the hand that the customer can program.
- (4) Emergency stop/Door switch input .. Information on wiring the emergency stop and wiring used to ensure safety can be found on [Page 60, "3.6 Emergency stop input and output etc."](#) and [Page 98, "6.1.3 Examples of safety measures"](#).

<For Reference>

Linking our GOT2000 Series display equipment to the robot controller over the Ethernet permits you to control robot controller's input/output from a GOT (graphic operation terminal).

3.5 Dedicated input/output

Show the main function of dedicated input/output in the [Table 3-3](#). Refer to attached instruction manual "Detailed explanations of functions and operations" in the product for the other functions. Each parameter indicated with the parameter name is used by designated the signal No., assigned in the order of input signal No. and output signal No.

Table 3-3: Dedicated input/output list

Parameter name	Input <small>Note1)</small>			Output	
	Name	Function	Level	Name	Function
TEACHMD	None			Teaching mode output signal	Outputs that the teaching mode is entered.
ATTOPMD	None			Automatic mode output signal	Outputs that the automatic mode is entered.
ATEXTMD	None			Remote mode output signal	Outputs that the remote mode is entered.
RCREADY	None			Controller power ON complete signal	Outputs that external input signals can be received.
AUTOENA	Automatic operation enabled input signal	Allows automatic operation.	L	Automatic operation enabled output signal	Outputs the automatic operation enabled state.
START	Start input signal	Starts all slots.	E	Operating output signal	Outputs that the slot is operating.
STOP	Stop input signal	Stops all slots. The input signal No. is fixed to 0. Note) Use the emergency stop input for stop inputs related to safety.	L	Wait output signal	Outputs that the slot is temporarily stopped.
STOP2	Stop input signal	The program during operation is stopped. Unlike the STOP parameter, change of the signal number is possible. Notes) Specification is the same as the STOP parameter.	L	Wait output signal	Outputs that the slot is temporarily stopped. Notes) Specification is the same as the STOP parameter.
SLOTINIT	Program reset input signal	Resets the wait state.	E	Program selection enabled output signal	Outputs that the slot is in the program selection enabled state.
ERRRESET	Error reset input signal	Resets the error state.	E	Error occurring output signal	Outputs that an error has occurred.
CYCLE	Cycle stop input signal	Carries out cycle stop.	E	In cycle stop operation output signal	Outputs that the cycle stop is operating.
SRVOFF	Servo ON enabled input signal	Turns the servo OFF for all mechanisms.	L	Servo ON enabled output signal	Outputs servo-on disable status. (Echo back)
SRVON	Servo ON input signal	Powers on the robot servos. For multiple mechanisms, it powers on the servos of all the mechanisms.	E	In servo ON output signal	Outputs the servo ON state. For multiple mechanisms, the output is performed when at least one of the mechanisms is in the servo ON state.
IOENA	Operation rights input signal	Requests the operation rights for the external signal control.	L	Operation rights output signal	Outputs the operation rights valid state for the external signal control.
MELOCK	Machine lock input signal	Sets/resets the machine lock state for all mechanisms.	E	In machine lock output signal	Outputs the machine lock state.
SAFEPOS	Evasion point return input signal	Requests the evasion point return operation.	E	In evasion point return output signal	Outputs that the evasion point return is taking place.

Parameter name	Input Note1)			Output	
	Name	Function	Level	Name	Function
OUTRESET	General-purpose output signal reset	Resets the general-purpose output signal.	E	None	
EMGERR	None			Emergency stop output signal	Outputs that an emergency stop has occurred.
S1START : S32START	Start input	Starts each slot.	E	In operation output	Outputs the operating state for each slot.
S1STOP : S32STOP	Stop input	Stops each slot.	L	In wait output	Outputs that each slot is temporarily stopped.
PRGSEL	Program selection input signal	Designates the setting value for the program No. with numeric value input signals.	E	None	
OVRDSEL	Override selection input signal	Designates the setting value for the override with the numeric value input signals.	E	None	
IODATA Note2)	Numeric value input (start No., end No.)	Used to designate the program name, override value., mechanism value.	L	Numeric value output (start No., end No.)	Used to output the program name, override value., mechanism No.
PRGOUT	Program No. output request	Requests output of the program name.	E	Program No. output signal	Outputs that the program name is being output to the numeric value output signal.
LINEOUT	Line No. output request	Requests output of the line No.	E	Line No. output signal	Outputs that the line No. is being output to the numeric value output signal.
OVRDOUT	Override value output request	Requests the override output.	E	Override value output signal	Outputs that the override value is being output to the numeric value output signal.
ERROUT	Error No. output request	Requests the error No. output.	E	Error No. output signal	Outputs that the error No. is being output to the numeric value output signal.
JOGENA	Jog valid input signal	Validates jog operation with the external signals	E	Jog valid output signal	Outputs that the jog operation with external signals is valid.
JOGM	Jog mode input 2-bit	Designates the jog mode.	L	Jog mode output 2-bit	Outputs the current jog mode.
JOG+	Jog feed + side for 8-axes	Requests the + side jog operation.	L	None	
JOG-	Jog feed - side for 8-axes	Requests the - side jog operation.	L	None	
HNDCTRL1 : HNDCTRL3	None			Mechanism 1 hand output signal status : Mechanism 3 hand output signal status	Mechanism 1: Outputs the status of general-purpose outputs 900 to 907. Mechanism 2: Outputs the status of general-purpose outputs 910 to 917. Mechanism 3: Outputs the status of general-purpose outputs 920 to 927.
HNDSTS1 : HNDSTS3	None			Mechanism 1 hand input signal status : Mechanism 3 hand input signal status	Mechanism 1: Outputs the status of hand inputs 900 to 907. Mechanism 2: Outputs the status of hand inputs 910 to 917. Mechanism 3: Outputs the status of hand inputs 920 to 927.

Parameter name	Input Note1)			Output	
	Name	Function	Level	Name	Function
HNDERR1 : HNDERR3	Mechanism 1 hand error input signal : Mechanism 3 hand error input signal	Requests the hand error occurrence.	L	Mechanism 1 hand error output signal : Mechanism 3 hand error output signal	Outputs that a hand error is occurring.
AIRERR1 : AIRERR3	Pneumatic pressure error 1 input signal : Pneumatic pressure error 3 input signal	Request the pneumatic pressure error occurrence.	L	Pneumatic pressure error 1 output signal. : Pneumatic pressure error 3 output signal.	Outputs that a pneumatic pressure error is occurring.
M1PTEXC : M3PTEXC	None		L	Maintenance parts replacement time warning signal	Outputs that the maintenance parts have reached the replacement time.
USERAREA Note3)	None			User-designated area 32-points	Outputs that the robot is in the user-designated area.

Note1) The level indicates the signal level.

L: Level signal → The designated function is validated when the signal is ON, and is invalidated when the signal is OFF.

E: Edge signal → The designated function is validated when the signal changes from the OFF to ON state, and the function maintains the original state even when the signal then turns OFF.

Note2) Four elements are set in the order of input signal start No., end No., output signal start No. and end No.

Note3) Up to eight points can be set successively in order of start output signal No. and end output signal No.

3.6 Emergency stop input and output etc.

Do wiring of the external emergency stop, the special stop input, the door switch, and the mode selector switch from the "special input/output" terminal connector.

Table 3-4: Special input/output terminal

Item	Name	Function
Input	Emergency stop	Applies the emergency stop. Dual line, normal close
Input	Special stop input	Applies the stop. (Refer to Page 65, "3.6.2 Special stop input (SKIP)")
Input	Door switch	Servo-off. Dual line, normal close (Page 66, "3.6.3 Door switch function")
Input	Mode selector switch	Changes the mode (MANUAL/AUTOMATIC) of the controller. Dual line (Page 66, "3.6.4 Mode selector switch function")
Output	Robot error output	Contact is opening during error occurrence.
Output	Emergency stop output	The point of contact opens under occurrence of emergency stop of external input signal, emergency stop of T/B.
Output	Mode output	MANUAL mode: contactor is opening, AUTOMATIC mode: contactor is closing.

*At the time of the power supply OFF, the output point of contact is always open.

[Note] Wire for each input terminal as shown in Fig. 3-11.

The contact capacity of each input/output terminal is DC24V/100mA. Do not connect the equipment except for this range. Noise or other effects that overload contact capacities will lead to failure. An example of noise prevention is shown in Fig. 3-8.

In the customer's system, do not ground the + side of 24V power supply prepared by customer for connect to the controller. (related with emergency stop and parallel input/output) If it connects to the controller under the condition that the + side is grounded, it will lead to failure of controller.

An example of connecting devices such as PLCs

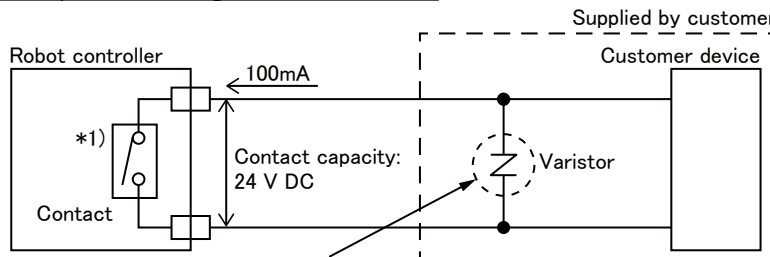

Use noise prevention methods that are specific to the devices being used and the environment they are being used in.

An example of connecting devices such as relays

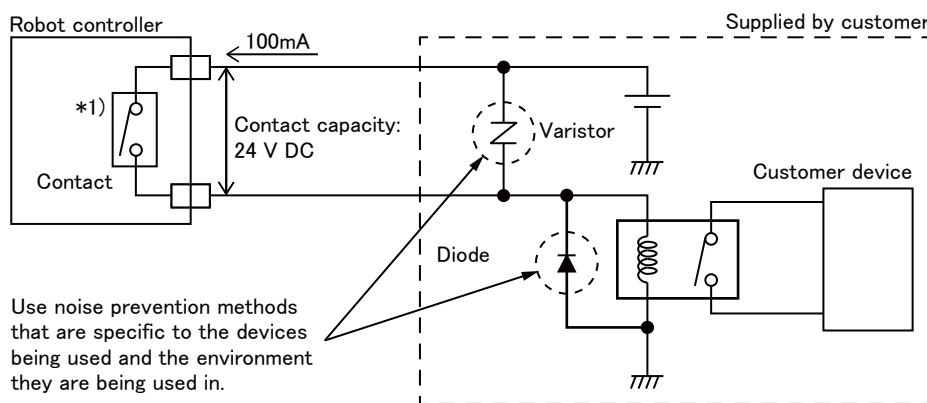

*1) The actual internal robot controller circuit differs from the internal robot controller circuit in the figure.

Recommended varistor

Model	Manufacturer	Varistor voltage	Max. permissible circuit voltage
ERZV10D390	Panasonic	39V	31V
72210S0250K101	TDK	39V	31V

Fig.3-8: Protection circuit example

[Note] If a stop signal or servo OFF signal is input simultaneously with a door switch open/emergency stop input, the error, H056n "Servo sys. error (A/D)" may occur.

When a door switch open/emergency stop is input, the robot turns off the servo after it stops. It is unnecessary to input a stop signal or servo OFF signal. To input a stop signal or servo OFF signal with a door switch open/emergency stop input, wait for 100ms or more after a door switch open/emergency stop input.

Pin number assignment of each terminal and the circuit diagram are shown in Fig. 3-11.

3.6.1 Connection of the external emergency stop and mode selector switch

The input terminals for the external emergency stop, door switch, and mode selector switch are arranged as shown in Fig. 3-11. Customers should be sure to prepare the external emergency stop, door switch, and mode selector switch, etc. and use the robot while these are connected. Connection procedures are shown below.

In addition, refer to Page 98, "6.1.3 Examples of safety measures" for the information on the emergency stop connection and cautions.

[Caution] The emergency stop circuit is duplicated inside the controller. The emergency stop switch uses a double contact-type switch, so please be sure to fix both of the contacts to the connector pins as shown below in order to ensure the wiring is duplicated. An error will continue to occur in the event that only one of the pins is connected.

- 1) Please prepare the emergency stop switch, door switch, and mode selector switch.
- 2) Connect the contacts of each switch to the contacts as shown below:
 - a) External emergency stop switch
CNUSR11 connector "between 7 and 23" and "between 14 and 30".
 - b) Door switch
CNUSR11 connector "between 6 and 22" and "between 13 and 29".
 - c) Mode selector switch
CNUSR11 connector "between 5 and 21" and "between 12 and 28".

[Caution] Be sure to use a shield cable for the emergency stop wiring cable and dedicated stop input wiring cable. And when operating in an environment that is easily affected by noise, be sure to install the ferrite core (recommended model name: E04SR301334, manufacturer: Seiwa Electric Mfg. Co., Ltd.). Be sure to place the ferrite core in 300mm or less from the connecting terminal section.

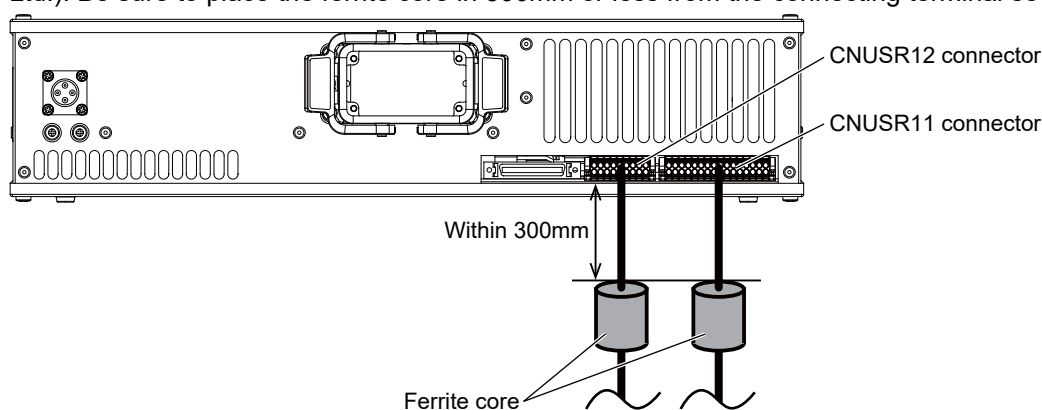

Fig.3-9: Installation position of ferrite cores

For information on the installation method, follow the instructions of the ferrite core being used.

⚠ CAUTION Make sure there are no mistakes in the wiring. Connecting differently to the way specified in the manual can result in errors, such as the emergency stop not being released. In order to prevent errors occurring, please be sure to check that all functions (such as the teaching box emergency stop, customer emergency stop, and door switch) are working properly after the wiring setup is completed.

⚠ CAUTION You should always connect doubly connection of the emergency stop, the door switch, and the mode selector switch. In connection of only one side, if the relay of customer use should break down, it may not function correctly. The robot output contacts (error output, emergency stop output, mode output) are duplicated output contacts that are wired in series. As with emergency stop switches and door switches, ensure that all connections to customer devices are duplicated to achieve redundancy.

⚠ CAUTION Please make sure to wire the multiple emergency stop switches so that they each function independently. Check and make sure that the emergency stop doesn't only function under an AND condition (when multiple emergency stop switches are ON at the same time).

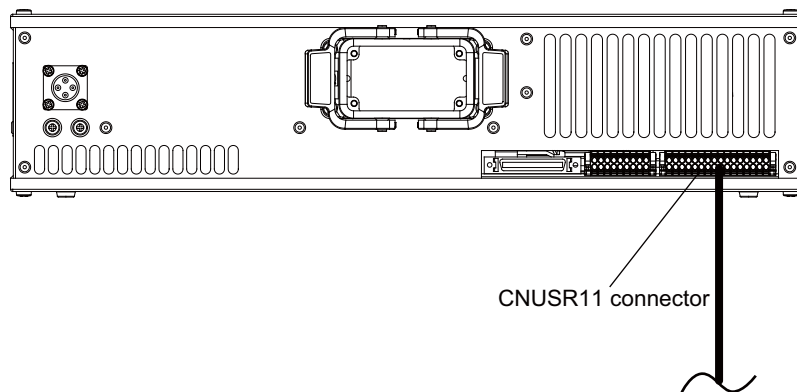

Fig.3-10: Emergency stop cable and mode selector switch connection

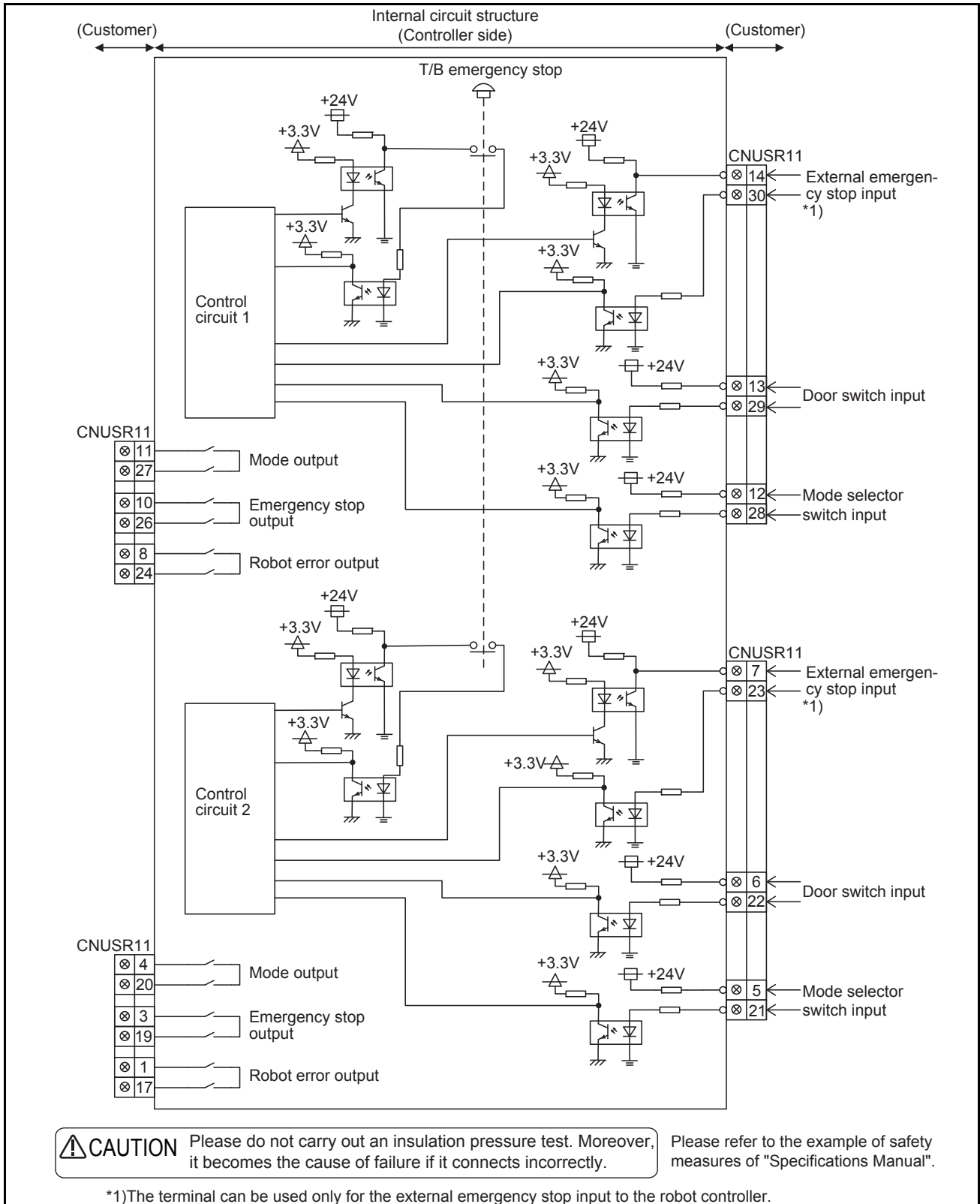

Fig.3-11: External emergency stop connection

CAUTION Place the emergency stop switch in an easily operable position, and be sure to wire it to the emergency stop correctly by referencing [Page 98, "6.1.3 Examples of safety measures"](#). This is a necessary measure in order to ensure safe operation so that the robot can be stopped immediately by pressing the emergency stop switch in the event that the robot malfunctions.

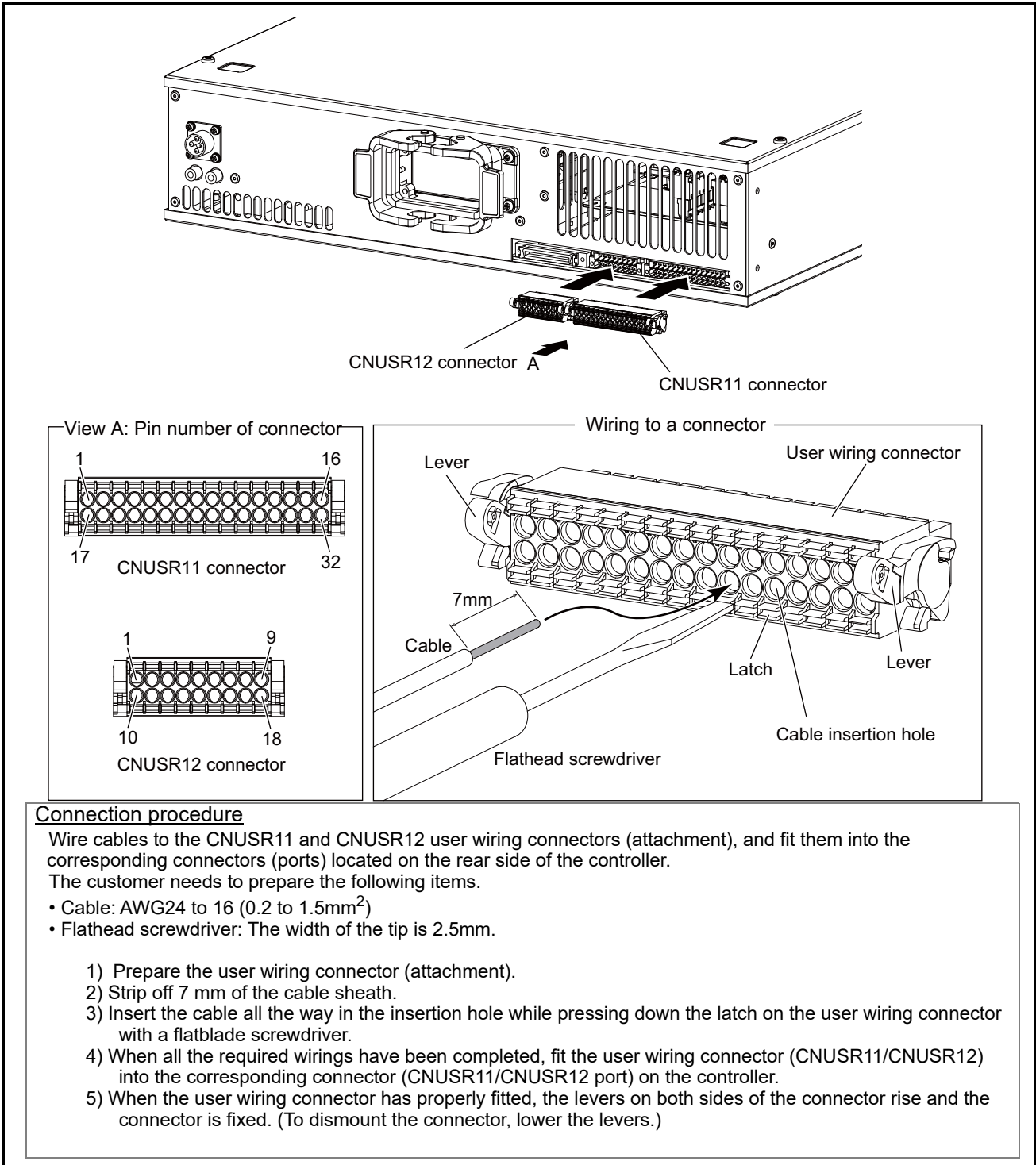

Fig.3-12: Wiring method to the user wiring connector

CAUTION Fully check the number of the cable insertion hole (connector pin number) for incorrect connection. Incorrect wiring may damage the robot or cause a malfunction.

CAUTION When wiring to the CNUSR11/CNUSR12 connector, pay attention to fraying wires of the core wires. The fraying wires can come into contact with the adjacent terminal, causing a short circuit.
 Do not apply solder on core wires. Doing so may cause a contact failure.

3.6.2 Special stop input (SKIP)

The SKIP is the input signal to stop the robot. Please connect the pin 4, 13 of the CNUSR12 connector shown in Fig. 3-13.

Table 3-5: Special stop input electric specification

Item		Specifications	Internal circuit
Type		DC input	
No. of input point		1	
Insulation method		Photo-coupler insulation	
Rated input voltage		24VDC	
Rated input current		Approx. 11mA	
Working voltage range		21.6VDC to 26.4VDC (Ripple rate within 5%)	
ON voltage/ON current		8VDC or more / 2mA or more	
OFF voltage/OFF current		4VDC or less / 1mA or less	
Input resistance		Approx. 2.2kΩ	
Response time	OFF→ON	1ms or less	
	ON→OFF	1ms or less	
Common method		1 point per common	
External wire connection method		Connector	

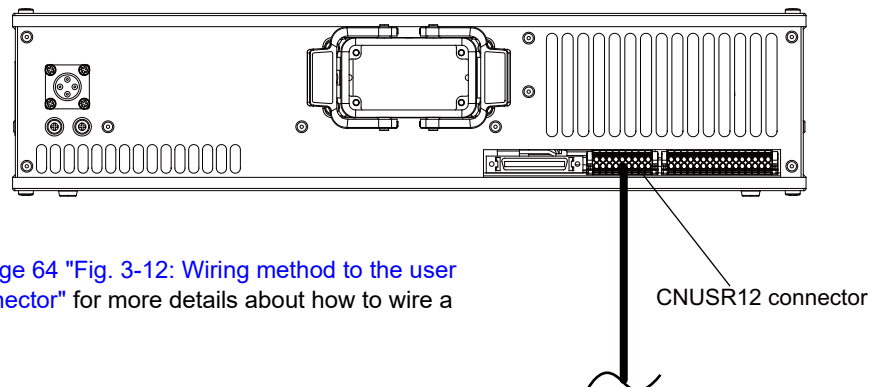

Note) In the customer's system, do not ground the + side of 24V power supply prepared by customer for connect to the controller. (related with emergency stop and parallel input/output) If it connects with the controller under the condition that the + side is grounded, it will lead to failure of controller.

Fig.3-13: Connection of the special-stop-input

3.6.3 Door switch function

This function uses the status of door switches to turn robot servos OFF when the door of a machine guard is opened.

Follow the wiring example shown in [Page 63 "Fig. 3-11: External emergency stop connection"](#) and [Page 98, "6.1.3 Examples of safety measures"](#). Details of this function according to the robot status are shown below (Fig. 3-14).

*During automatic operationWhen the door is opened, the servo turns OFF and the robot stops. An error occurs. The process of the restoration: Close the door, reset the alarm, turn on the servo, and restart.

*During teaching.....Even when the door is opened, using a selector switch allows to turn the servo ON with the teaching pendant to operate the robot.

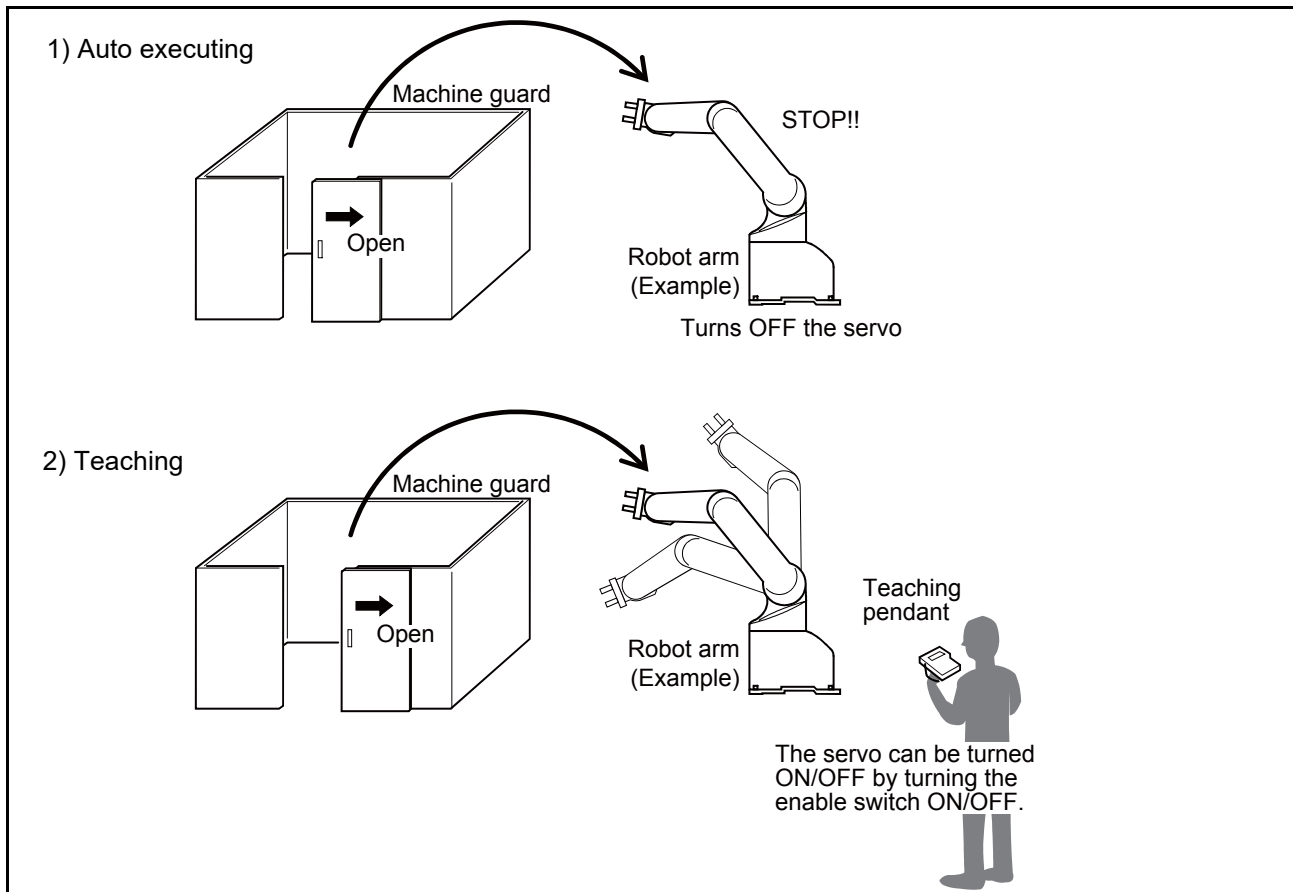

Fig.3-14: Door switch function

3.6.4 Mode selector switch function

The mode selector switch switches the mode of the controller between MANUAL mode and AUTOMATIC mode.

Table 3-6: States of input terminal

Mode of controller	Input terminal
MANUAL (Teaching)	Open
AUTOMATIC (Automatic operation)	Close

(1) Automatic Operation/Jog Operation/Brake Release and Necessary Switch Settings

The following is a description of various operations performed on the robot and switch settings that are required.

Table 3-7: Various operations and necessary switch settings

No	Operation ^{Note1)}	Method of operation	Related switch settings ^{Note1) Note2)}					Description
			T/B enable/disable	T/B enable switch	Mode selector switch input terminal	Door switch input terminal	Safety input 1	
1	Jog operation	T/B	Enable	ON	Open (MANUAL mode)	-	-	If the mode selector switch input is set to Open (MANUAL mode), the state of door switch input does not matter.
		RT VisualBox RT ToolBox3	Disable	-	Close (AUTOMATIC mode)	Close (Door Close)	-	The door switch input status must be "closed" (door closed).
2	Brake release ^{Note3)}	T/B	Enable	ON	Open (MANUAL mode)	-	-	If the mode selector switch input is set to Open (MANUAL mode), the state of door switch input does not matter.
		RT VisualBox	Disable	-	Close (AUTOMATIC mode)	-	-	If the door switch input is set to Open (door opened), the error H0040 (Door Switch Signal is Input) will occur, but the brakes can be released.
3	Automatic operation	T/B RT VisualBox RT ToolBox3	Disable	-	Close (AUTOMATIC mode)	Close (Door Close)	-	The door switch input status must be "closed" (door closed).
4		Operation buttons	Disable	-	Close (AUTOMATIC mode)	Close (Door Close)	Open (collaborative operation)	The door switch input status must be "closed" (door closed). Safety input 1 must be set to "Open" (collaborative operation).
5		T/B	Enable	ON	Open (MANUAL mode)	-	-	If the mode selector switch input is set to Open (MANUAL mode) and automatic operation is performed, the robot will operate at the safe speed (250 mm/s) or less.
6	Direct teaching	Operation buttons RT VisualBox RT ToolBox3	Disable	-	Close (AUTOMATIC mode)	Close (Door Close)	Open (collaborative operation).	The door switch input status must be "closed" (door closed). Safety input 1 must be set to "Open" (collaborative operation).

Note1) Regardless of the operation mode or the input terminal status indicated in Table 3-7, the possible statuses of the robot in collaborative operation mode are indicated in the table below.

Collaborative operation mode	Safety input 1	Location of the robot relative to the low-speed space
High-speed operation mode	Close	-
Collaborative operation mode (Standard operation)	Open	Outside the space
Collaborative operation mode (Low-speed operation)	Open	Inside the space

Note2) "-" in the table indicates that the state of switch concerned does not matter.

Refer to the following for operation of each switch.

- T/B enable/disable: [Page 70, "\(1\) Teaching pendant \(T/B\)"](#)
- T/B enable switch: [Page 70, "\(1\) Teaching pendant \(T/B\)"](#)
- Mode selector switch input terminal: [Page 98, "6.1.3 Examples of safety measures"](#)
- Door switch input terminal: [Page 98, "6.1.3 Examples of safety measures"](#)

Note3)

 **CAUTION**

Upon the release of brake, the robot arm may fall under its own weight depending on the axis which has been released. To ensure safety, take appropriate measures such as supporting the axis to avoid the free fall.

 **WARNING**

Be sure to prepare one brake release method at the robot usage site.

3.7 Options

- What are options?

There are a variety of options for the robot designed to make the setting up process easier for user needs. User installation is required for the options.

(1) Teaching pendant (T/B)

- Order type: ● R32TB :Cable length 7m
- R32TB-15 :Cable length 15m

■ Outline



This is used to create, edit and control the program, teach the operation position and for jog feed, etc. For safety proposes, a 3-position enable switch is mounted.*1)

For multiple robots, you can operate them with just one teaching pendant by repeating the removal of it from another robot and the connection of it to the target robot.

■ Configuration

Table 3-8: Configuration device

Part name	Type	Qty.	Mass (kg) ^{Note1)}	Remarks
Teaching pendant	R32TB	Either one pc.	1.7	Cable 7 m, Ver. 1.9.5 or later
	R32TB-15		2.8	Cable 15 m, Ver. 1.9.5 or later

Note1) Mass indicates one set.

■ Specifications

Table 3-9: Specifications

Items	Specifications	Remarks
Outline dimensions	195(W) x 292(H) x 106(D) (refer to outline drawing)	
Body color	Dark gray	
Mass	Approx. 0.9kg (body only, excluding cables)	
Connection method	Connects with controller via connector.	
Interface	RS-422	
Display method	LCD method: 24 characters x 8 lines, LCD illumination: with backlight	At 8x8 font
Operation section	36 keys	

*1) <3-position enable switch>

In ISO 10218-1: 2011 and JIS B 8433-1: 2015, this is defined as an "enable device". These standards specify that the robot operation using the teaching pendant is enabled only when the "enable device" is at a specified position.

With the Mitsubishi Electric industrial robot, the above "enable device" is configured of an "Enable/Disable switch" and "Enable switch".

The 3-position enable switch has three statuses. The following modes are entered according to the switch state.

- a) "Not pressed" The robot does not operate. *)
- b) "Pressed lightly" The robot can be operated and teaching is possible.
- c) "Pressed with force" The robot does not operate. *)

*) Releasing or forcefully pressing the 3-position enable switch cuts power to the servos in the same way as when the emergency stop is input. This helps to ensure safety.

Operations such as editing programs and displaying the robot's status are possible while the 3-position enable switch is released or forcefully pressed (excludes operating the robot).

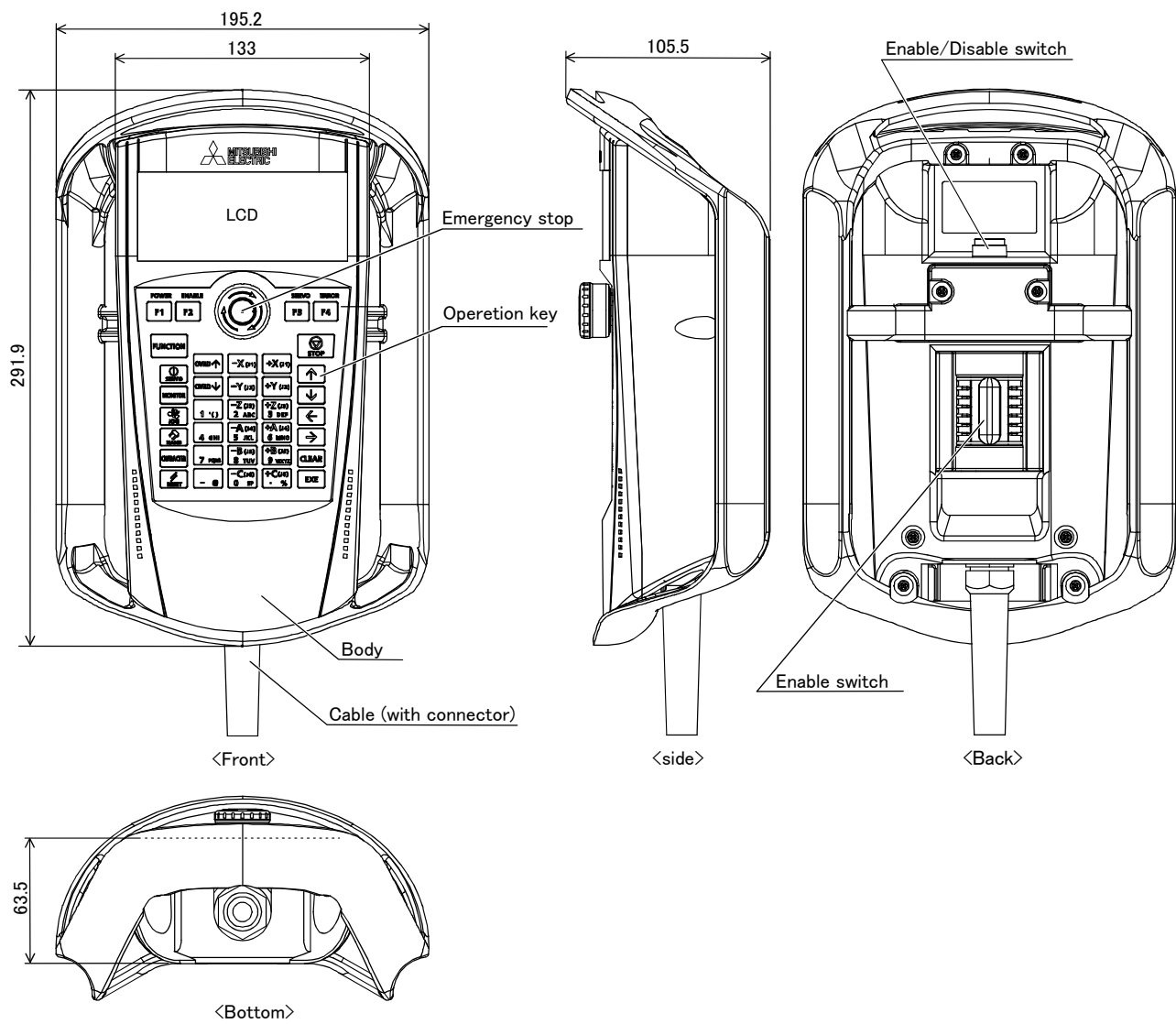
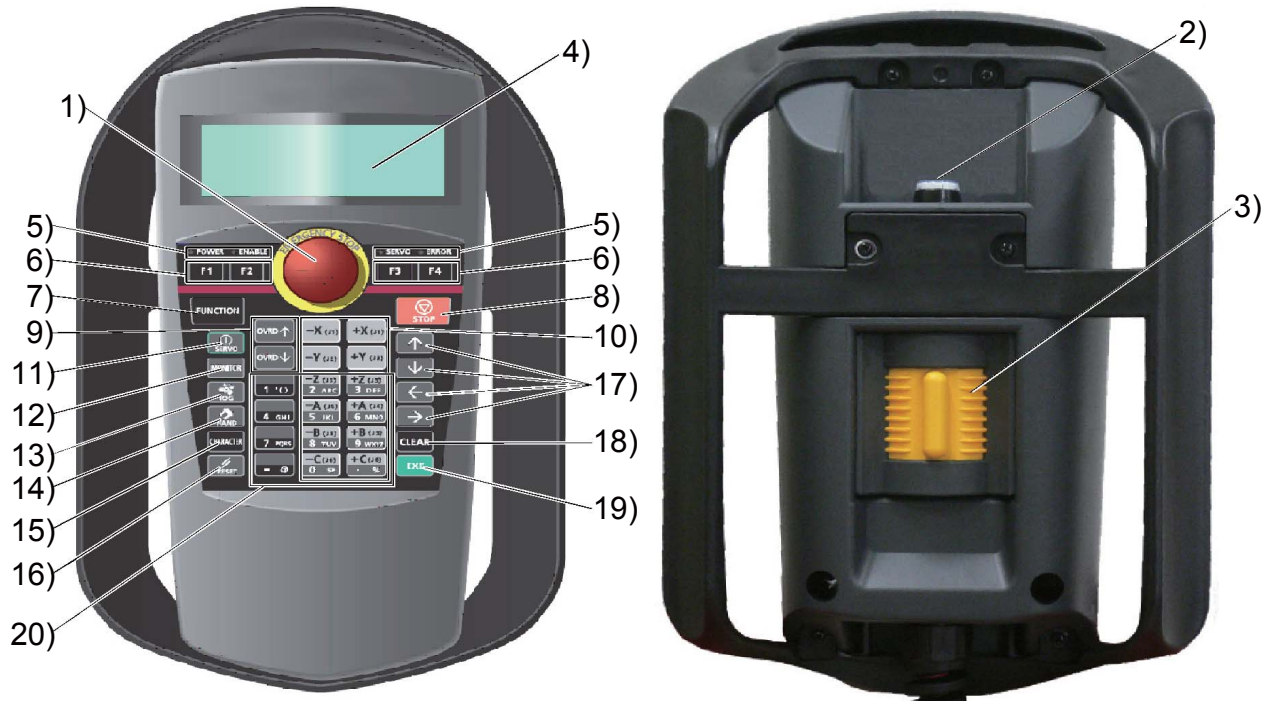

Fig.3-15: Outside dimensions of teaching pendant

■ Installation method

The teaching pendant is connected to the TB connector on the front of the controller.

■Key layout and main functions



- 1) [Emergency stop] switch The robot servo turns OFF and the operation stops immediately.
- 2) [TB ENABLE] switch..... This switch changes the T/B key operation between enable and disable.
- 3) Enable switch When the [Enable/Disable] switch "2)" is enabled, and this key is released or pressed with force, the servo will turn OFF, and the operating robot will stop immediately.
- 4) LCD display panel The robot status and various menus are displayed.
- 5) Status display lamp Display the state of the robot or T/B.
- 6) [F1], [F2], [F3], [F4]..... Execute the function corresponding to each function currently displayed on LCD.
- 7) [FUNCTION] key Switch the function display to check another functions assigned to the function keys ([F1], [F2], [F3], and [F4]) when five or more functions are available for next operation, where only four function keys are available.
- 8) [STOP] key This stops the program and decelerates the robot to a stop.
- 9) [OVRD↑][OVRD↓] key Change moving speed. Speed goes up by [OVRD↑] key. Speed goes down by [OVRD↓] key
- 10) [JOG] operation key Move the robot according to jog mode. And, input the numerical value.
- 11) [SERVO] key..... Press this key with holding enable switch lightly, then servo power will turn on.
- 12) [MONITOR] key It becomes monitor mode and display the monitor menu.
- 13) [JOG] key It becomes jog mode and display the jog operation.
- 14) [HAND] key..... It becomes hand mode and display the hand operation.
- 15) [CHARACTER] key Switch the function of the number/character keys between number input and character (letter or some special character) input when both inputs are available on the T/B.
- 16) [RESET] key This resets the error. The program reset will execute, if this key and the [EXE] key are pressed.
- 17) [↑][↓][←][→] key Moves the cursor each direction.
- 18) [CLEAR] key Erase a text on the cursor position when number/character input is available.
- 19) [EXE] key..... Input operation is fixed. And, while pressing this key, the robot moves when direct mode.
- 20) Number/character key Input the number or character when the number/character input is available.

Fig.3-16: Teaching pendant key layout and main functions

(2) High efficient teaching pendant (T/B)

- Order type: ● R56TB : Cable length 7m
- R56TB-15 : Cable length 15m

■ Outline



This is used to create, edit and control the program, to teach the operation position, or to perform jog feed, etc. This highly efficient teaching pendant has a touchscreen graphical user interface (GUI) which allows easy operation. In addition, the 3-position enable switch ^{*1)} is provided for the safety use. For multiple robots, you can operate them with just one teaching pendant by repeating the removal of it from another robot and the connection of it to the target robot.

■ Configuration

Table 3-10: Configuration device

Part name	Type	Qty.	Mass (kg) ^{Note1)}	Remarks
High efficient teaching pendant	R56TB	Either one pc.	2.1	Cable 7 m, Ver. 4.2 or later
	R56TB-15		3.2	Cable 15 m, Ver. 4.2 or later

Note1) Mass indicates one set.

■ Specifications

Table 3-11: Specifications

Items	Specifications	Remarks
Outline dimensions	252(W) x 240(H) x 114(D) (refer to outline drawing)	
Body color	Dark gray	
Mass	Approx. 1.25kg (body only, excluding cables)	
Connection method	Connects with controller via connector.	
Interface	RS-422, Ethernet (10BASE-T)	For connection with robot controller
	USB host	Note1)
Display	6.5" TFT (640 x 480) color touchscreen, with backlight	

Note1) The operation of the following USB memory sticks has been confirmed.

- a) Kingston Data Traveler Manufacture: Kingston, Type: USB 2.0 memory stick, Memory sizes: 128 MB - 1GB
- b) Transcend Jet Flash Manufacture: Transcend, Type: USB 2.0 memory stick, Memory sizes: 128 MB - 1GB

Notice) The operation of those other than the above is not guaranteed.

■ Installation method

The teaching pendant is connected to the TB connector on the front of the controller.

*1) <3-position enable switch>

In ISO 10218-1: 2011 and JIS B 8433-1: 2015, this is defined as an "enable device". These standards specify that the robot operation using the teaching pendant is enabled only when the "enable device" is at a specified position.

With the Mitsubishi Electric industrial robot, the above "enable device" is configured of an "Enable/Disable switch" and "Enable switch".

The 3-position enable switch has three statuses. The following modes are entered according to the switch state.

- a) "Not pressed"The robot does not operate.
- b) "Pressed lightly"The robot can be operated and teaching is possible.
- c) "Pressed with force"The robot does not operate.

*) Releasing or forcefully pressing the 3-position enable switch cuts power to the servos in the same way as when the emergency stop is input. This helps to ensure safety.

Operations such as editing programs and displaying the robot's status are possible while the 3-position enable switch is released or forcefully pressed (excludes operating the robot).

■ Outside dimensions and main functions

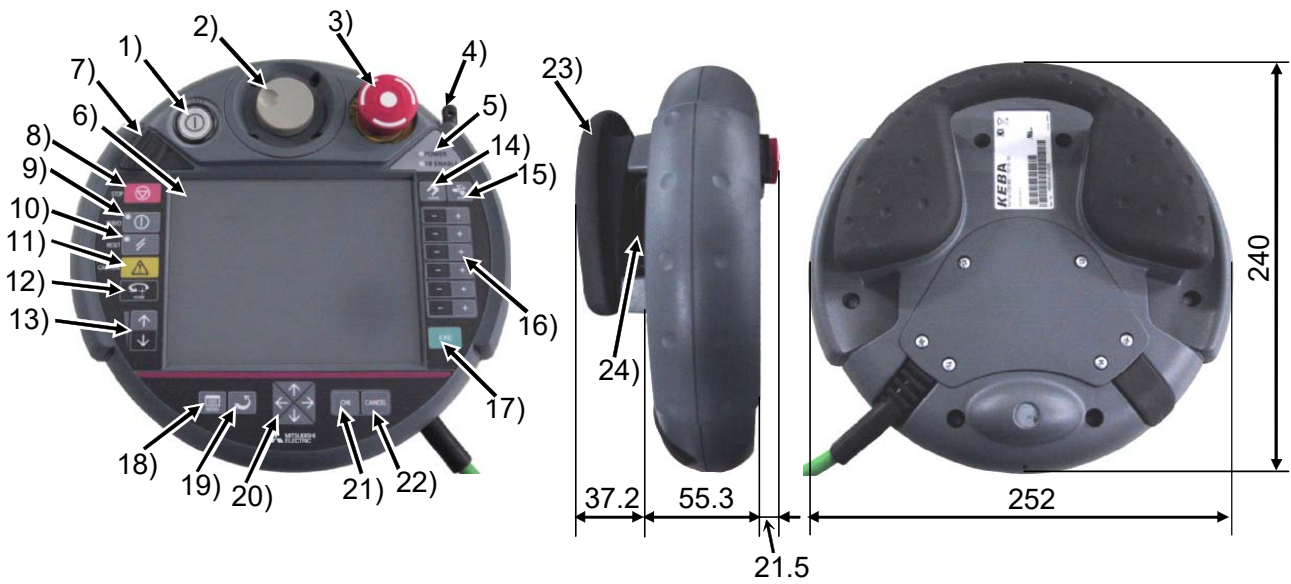

- 1) TEACH button..... This changeover switch is used to enable or disable the T/B key operations. The lamp (white) lights up during enabling state.
- 2) Wheel..... Move the cursor to select the menu and so on.
- 3) Emergency stop switch..... This stops the robot in an emergency state. The servo turns OFF. Turn to the right to cancel.
- 4) Touch stylus (Integrated in housing)
The pen which operates the touch panel.
- 5) Power supply LED, T/B enable LED
POWER LED lights up during supplying the power supply. TB ENABLE LED lights up during enabling state.
- 6) Touch panel..... Tap to operate with the stylus pen and the screen is displayed.
- 7) USB connector..... Plug-in the USB memory stick.
- 8) STOP button This stops the robot immediately. The servo does not turn OFF.
- 9) SERVO button This turns ON the servo power simultaneously with the enable switch. The LED (green) lights during servo ON.
- 10) RESET button This key resets an error state that has occurred.
- 11) CAUTION button If this button is pushed in jog operation, the limit switch can be canceled. Moreover, push this button, when releasing the brake.
- 12) HOME button Not use.
- 13) OVRD button..... This scrolls override up or down.
- 14) HAND button..... Display the screen of hand operation.
- 15) JOG button..... Display the screen of jog operation.
- 16) +/- button..... This button operates corresponding to the selected operation.
- 17) EXE button..... Move the robot, such as hand alignment.
- 18) MENU button Display the menu screen.
- 19) RETURN button Close each operation screen.
- 20) Arrow button..... Move the cursor
- 21) OK button..... Fix each screen operation.
- 22) CANCEL button Cancel each screen operation.
- 23) Multi grip handle..... Holds the T/B.
- 24) Enable switch..... If this switch is released or pressed with force while the T/B is enabled, the servo power supply turns OFF. To move the robot in jog operation or the like, press the switch lightly and hold it. The enable switch is mounted on each of the multi grip handle.

Fig.3-17: Teaching pendant outside dimensions and main functions

(3) MELSOFT RT ToolBox3/MELSOFT RT ToolBox3 mini

- Order type:
 - MELSOFT RT ToolBox3
*For windows DVD-ROM : 3F-14C-WINE
 - MELSOFT RT ToolBox3 mini
*For windows DVD-ROM : 3F-15C-WINE

■ Outline



RT ToolBox3 has a wide range of uses, which include assisting with program design (editing and creation), setup (program execution, management, debugging), maintenance, and checking robot specifications (tact time etc.).

■ Configuration

Table 3-12: Product configuration

Part name	Type	Medium	Mass (kg) ^{Note1)}	Remarks
RT ToolBox3	3F-14C-WINE	DVD-ROM	0.2	Ver.1.70Y or later
RT ToolBox3 mini	3F-15C-WINE	DVD-ROM	0.2	Ver.1.70Y or later

Note1) Mass indicates one set.

■ Features

(1) Simple operation with guidance method and menu method

The Windows standard is used for windows operation, so the controller initialization and startup operations can be carried out easily by following the instructions given on the screen. Even a beginner can easily carry out the series of operations from program creation to execution.

(2) Increased work efficiency with ample support functions

The work efficiency is greatly improved with the multi-window method that carries out multiple steps and displays in parallel. The renumbering function, and copy, search, syntax check and step execution are especially sufficient, and are extremely useful when editing or debugging the program.

With the simulation function support of MELSOFT RT ToolBox3, the program can be debugged and the tact checked before starting the machine at the site. This allows the on-site startup work efficiently to be greatly improved.

■Functions

Table 3-13: Functions

Function		Functional existence ^{Note1)}		Details
Compatible model		○	○	Personal computer running Windows 7, Windows 8, Windows 8.1, or Windows 10. ^{Note2)}
Program editing functions	Editing functions	○	○	<ul style="list-style-type: none"> • MELFA BASIC V, VI language compatible • Multiple editing screen simultaneously display • Command input, comment writing • Position data editing • File operation (writing to controller, personal computer) • Search and replace function (using characters, line Nos., labels) • Copy, cut, paste, insert (per character, line), undo (per command statement, position conversion) • Line No. automatic generation, renumbering • Batch syntax check • Command template • Position conversion batch editing • Position variable template • Print, print preview
	Control functions	○	○	• Program file control (list, copy, movement, delete, content comparison, name change, protect)
	Debugging functions	○	○	<ul style="list-style-type: none"> • Direct editing of program in controller • Confirmation of robot program operation (step execution, direct execution)
Simulation function		○	×	<ul style="list-style-type: none"> • Off-line simulation of robot program operation using CG (computer graphics) • Tact time calculation
Monitor functions		○	○	<ul style="list-style-type: none"> • Robot operation monitor (robot operation state, stop signal, error monitor, program monitor (execution program, variables), general-purpose input/output signals (forced output possible), dedicated input/output signals, operation confirmation (operation range, current position, hand, etc.)) • Operation monitor (working time statistics, production information, robot version) • Servo monitor (load)
Maintenance function		○	○	<ul style="list-style-type: none"> • Parameter setting • Batch, divided backup

— MELSOFT RT ToolBox3 mini (3F-15C-WINE)

— MELSOFT RT ToolBox3 (3F-14C-WINE)

Note1) The symbols "○" and "×" indicate whether the function is available for MELSOFT RT ToolBox3 and MELSOFT RT ToolBox3 mini. ○: available ×: unavailable

Note2) Recommend corresponding to CE Marking, an FCC standard, and a VCCI standard.

(4) MELSOFT RT VisualBox

- Order type: ● MELSOFT RT VisualBox
 *For windows CD-ROM : 3G-30C-WINE

■ Outline



RT VisualBox is intuitive, easy-to-use software with support for touch-screen devices. It enables users to easily set up and program robots, even without specialist robot knowledge.

■ Configuration

Table 3-14: Product configuration

Part name	Type	Medium	Mass (kg) ^{Note1)}	Remarks
MELSOFT RT VisualBox	3G-30C-WINE	CD-ROM	0.2	-

Note1) Mass indicates one set.

■ Features

- (1) Programming knowledge is not required as robots can be programmed visually using programming blocks.
 Users who do not understand robot programming language can easily create and debug programs just by placing operation blocks on screen. The robots direct teaching function also makes teaching positions to the robot more intuitive and efficient.
- (2) No time needs to be wasted configuring essential settings.
 Most of the settings appear in a wizard, so by following the on screen instructions settings can be easily configured in order to set the robot up.
- (3) The vision sensor can be setup and adjusted quicker than before.
 If using recommended vision sensors, you can create programs that incorporate vision sensors just by using RT VisualBox. Even functions that take a long time to set up and adjust, such as the calibration function, are easy to use. Just follow the on-screen instructions.

■ Functions

Table 3-15: Functions

Function		Details
Robot connection		Used to select how the robot is connected.
Initial settings		Used to configure the initial settings (installation type, hand settings, workpiece settings, and workpiece grasp position).
Programming	Visual programming (main screen)	<ul style="list-style-type: none"> • Programs can be created by dragging and dropping program blocks. • Programs can be executed and debugged. • The 3D layout and simulation can be viewed from this screen.
	Block properties	Used to configure the advance settings of each block.
	Robot operation panel	<ul style="list-style-type: none"> • Used to operate the robot. • The robot can be operated using the following four modes: direct teaching, jog, inching, and joint mode.
	Monitor	Taught positions, signals, variables, errors
Custom settings	Select language	Used to select the display language
	Workpiece grasp position settings	Used to configure the workpiece grasp position settings (These settings are available in the initial settings.)
	Signal settings	A separate name can be specified for each input signal and each output signal.
	Date and time settings	Used to set the date and time
Safety settings		Used to configure the mandatory settings of safety functions.
Vision sensor settings	Connection settings	Used to configure the vision sensor connection settings
	Workpiece transportation	Used to configure pick-up point and workpiece identification settings
Maintenance	Backup	Export data from the currently connected robot as a backup file
	Restore	Sends backup file data to the currently selected robot
	Origin settings	<ul style="list-style-type: none"> • Used to configure the origin settings of each axis • Used to release the brakes
	Parameter settings	Used to read and write parameters
Help	Manual	Displays the Instruction Manual for this product
	Software version	Shows the software version

(5) Parallel I/O interface

■ Order type : ● 2D-TZ368 (Sink type)/2D-TZ378 (Source type)

■ Outline



This is used to expand the external inputs and outputs.

- The connecting cable with external equipment is not attached. Since we are preparing the external input-and-output cable (2D-CBL05 or 2D-CBL15) as the option, please use.

■ Configuration

Table 3-16: Configuration device

Part name	Type	Qty.	Mass (kg) ^{Note1)}	Remarks
Parallel I/O interface	2D-TZ368	Either one pc.	0.4	Input/output 32 points/32 points 2D-TZ368 is sink type. 2D-TZ378 is source type.
	2D-TZ378			

Note1) Mass indicates one set.

■ Specifications

Table 3-17: Electrical specifications of input circuits

Item	Specification		Internal circuit
Type	DC input		<p><Sink type></p> <p><Source type></p>
Number of input points	32		
Insulation method	Photo coupler insulation		
Rated input voltage	12VDC	24VDC	
Rated input current	Approx. 3mA	Approx.9mA	
Working voltage range	10.2VDC to 26.4VDC (Ripple factor should be less than 5%)		
ON voltage/ON current	8VDC or more/2mA or more		
OFF voltage/ OFF current	4VDC or less/1mA or less		
Input resistance	Approx. 2.7kΩ		
Response time	OFF-ON	10ms or less(24VDC)	
	ON-OFF	10ms or less(24VDC)	
Common method	32 points per common		
External cable connection method	Connector		

Table 3-18: Electrical specifications for the output circuits

Item	Specification		Internal circuit
Type	Transistor output		<p><Sink type></p> <p><Source type></p>
No. of output points	32		
Insulation method	Photo-coupler insulation		
Rated load voltage	12VDC/24VDC		
Rated load voltage range	10.2VDC to 30VDC (peak voltage 30VDC)		
Max. load current	0.1A/point (100%)		
Leakage current at OFF	Within 0.1mA		
Max. voltage drop at ON	0.9VDC(TYP.) ^{Note1)}		
Response time	OFF-ON	10ms or less (Resistance load) (hardware response time)	
	ON-OFF	10ms or less (Resistance load) (hardware response time)	
Fuse rating	Fuse 1.6A (one per common) Replacement possible (max. 3)		
Common method	16 points per common (common terminal: 2points)		
External wire connection method	Connector		
External power supply	Voltage	12VDC/24VDC(10.2VDC to 30VDC)	
	Current	60mA (TYP.24VDC per common) (base drive current)	

Note1) The maximum voltage drop value at signal ON.

Refer to it for the equipment connected to the output circuit.

*A voltage exceeding the rated voltage or incorrect wiring may damage the circuit.

Caution

The protection fuse of the output circuit prevents the failure at the time of the load short circuit and incorrect connection. The load connected of the customer should be careful not to exceed maximum rating current. The internal transistor may be damaged if maximum rating current is exceeded.

■ Installation method

The expansion parallel input/output interface is installed in the controller. Refer to separate "Instruction Manual/Controller Setup and Maintenance" for details on the installing method.

If it installs in the option SLOT of the controller, the station number will be assigned automatically.

SLOT1: station number 0 (0 to 31)

SLOT2: station number 1 (32 to 63)

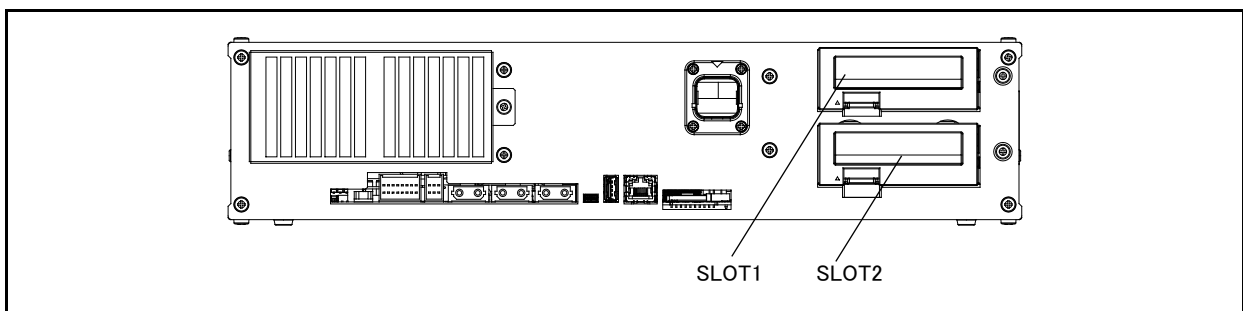

Fig.3-18: Parallel I/O interface installation position

■ Pin layout of connector

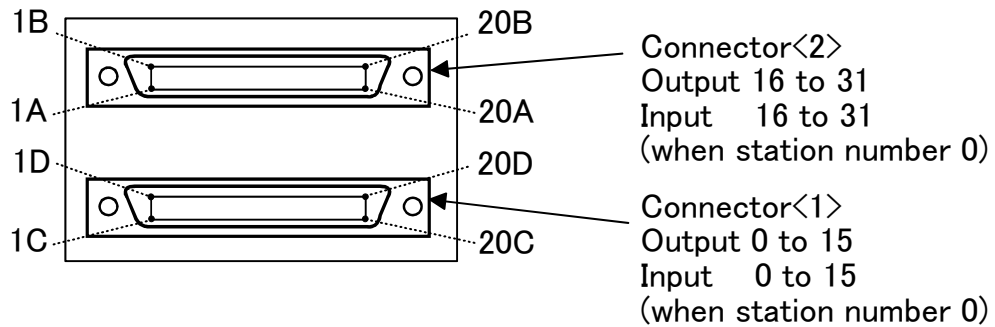

Fig.3-19: Pin layout of connector

■ Connector pin No. and signal assignment

The station number is fixed by the slot to install and the allocation range of the general-purpose input-and-output signal is fixed.

Table 3-19: The slot number and the station number

Slot number	Station number	Range of the general-purpose input-and-output signal	
		Connector <1>	Connector <2>
SLOT1	0	Input: 0 to 15 Output: 0 to 15	Input: 16 to 31 Output: 16 to 31
SLOT2	1	Input: 32 to 47 Output: 32 to 47	Input: 48 to 63 Output: 48 to 63

The connector pin number of the parallel input-and-output interface installed in SLOT1 and signal number allocation are shown in [Table 3-20](#) and [Table 3-21](#). If it installs in other slots, please interpret and utilize.

Table 3-20: Connector<1> pin assignment list and external I/O cable (2D-CBL**) color(SLOT1)

Pin No.	Line color	Function name		Pin No.	Line color	Function name	
		General-purpose	Dedicated/power supply, common			General-purpose	Dedicated/power supply, common
1C	Orange/Red a		24G/12G: For pins 5D-20D COM: For pins 5C-20C ^{Note1)} Reserved Reserved	1D	Orange/Black a		+24V/+12V(COM): For pins 5D-20D Reserved Reserved Reserved
2C	Gray/Red a			2D	Gray/Black a		
3C	White/Red a			3D	White/Black a		
4C	Yellow/Red a			4D	Yellow/Black a		
5C	Pink/Red a	General-purpose input 15		5D	Pink/Black a	General-purpose output 15	
6C	Orange/Red b	General-purpose input 14		6D	Orange/Black b	General-purpose output 14	
7C	Gray/Red b	General-purpose input 13		7D	Gray/Black b	General-purpose output 13	
8C	White/Red b	General-purpose input 12		8D	White/Black b	General-purpose output 12	
9C	Yellow/Red b	General-purpose input 11		9D	Yellow/Black b	General-purpose output 11	
10C	Pink/Red b	General-purpose input 10		10D	Pink/Black b	General-purpose output 10	
11C	Orange/Red c	General-purpose input 9		11D	Orange/Black c	General-purpose output 9	
12C	Gray/Red c	General-purpose input 8		12D	Gray/Black c	General-purpose output 8	
13C	White/Red c	General-purpose input 7		13D	White/Black c	General-purpose output 7	
14C	Yellow/Red c	General-purpose input 6		14D	Yellow/Black c	General-purpose output 6	
15C	Pink/Red c	General-purpose input 5	Operation rights input signal ^{Note2)}	15D	Pink/Black c	General-purpose output 5	
16C	Orange/Red d	General-purpose input 4	Servo ON input signal ^{Note2)}	16D	Orange/Black d	General-purpose output 4	
17C	Gray/Red d	General-purpose input 3	Start input ^{Note2)}	17D	Gray/Black d	General-purpose output 3	Operation rights output signal ^{Note2)}
18C	White/Red d	General-purpose input 2	Error reset input signal ^{Note2)}	18D	White/Black d	General-purpose output 2	Error occurring output signal ^{Note2)}
19C	Yellow/Red d	General-purpose input 1	Servo OFF input signal ^{Note2)}	19D	Yellow/Black d	General-purpose output 1	In servo ON output signal ^{Note2)}
20C	Pink/Red d	General-purpose input 0	Stop input ^{Note3)}	20D	Pink/Black d	General-purpose output 0	Operating output ^{Note2)}

Note1) Sink type: +24V/+12V(COM), Source type: 24G/12G

Note2) The dedicated signal is assigned at shipping. It can change with the parameter.

Note3) The dedicated input signal (STOP) is assigned at shipping. The signal number is fixing.

Table 3-21: Connector<2> pin assignment list and external I/O cable (2D-CBL**) color(SLOT1)

Pin No.	Line color	Function name		Pin No.	Line color	Function name	
		General-purpose	Dedicated/power supply, common			General-purpose	Dedicated/power supply, common
1A	Orange/Red a		24G/12G: For pins 5B-20B COM: For pins 5A-20A ^{Note1)} Reserved Reserved	1B	Orange/Black a		+24V/+12V(COM): For pins 5B-20B Reserved Reserved Reserved
2A	Gray/Red a			2B	Gray/Black a		
3A	White/Red a			3B	White/Black a		
4A	Yellow/Red a			4B	Yellow/Black a		
5A	Pink/Red a	General-purpose input 31		5B	Pink/Black a	General-purpose output 31	
6A	Orange/Red b	General-purpose input 30		6B	Orange/Black b	General-purpose output 30	
7A	Gray/Red b	General-purpose input 29		7B	Gray/Black b	General-purpose output 29	
8A	White/Red b	General-purpose input 28		8B	White/Black b	General-purpose output 28	
9A	Yellow/Red b	General-purpose input 27		9B	Yellow/Black b	General-purpose output 27	
10A	Pink/Red b	General-purpose input 26		10B	Pink/Black b	General-purpose output 26	
11A	Orange/Red c	General-purpose input 25		11B	Orange/Black c	General-purpose output 25	
12A	Gray/Red c	General-purpose input 24		12B	Gray/Black c	General-purpose output 24	
13A	White/Red c	General-purpose input 23		13B	White/Black c	General-purpose output 23	
14A	Yellow/Red c	General-purpose input 22		14B	Yellow/Black c	General-purpose output 22	
15A	Pink/Red c	General-purpose input 21		15B	Pink/Black c	General-purpose output 21	
16A	Orange/Red d	General-purpose input 20		16B	Orange/Black d	General-purpose output 20	
17A	Gray/Red d	General-purpose input 19		17B	Gray/Black d	General-purpose output 19	
18A	White/Red d	General-purpose input 18		18B	White/Black d	General-purpose output 18	
19A	Yellow/Red d	General-purpose input 17		19B	Yellow/Black d	General-purpose output 17	
20A	Pink/Red d	General-purpose input 16		20B	Pink/Black d	General-purpose output 16	

Note1) Sink type: +24V/+12V(COM), Source type: 24G/12G

<Reference> The example of connection with our PLC

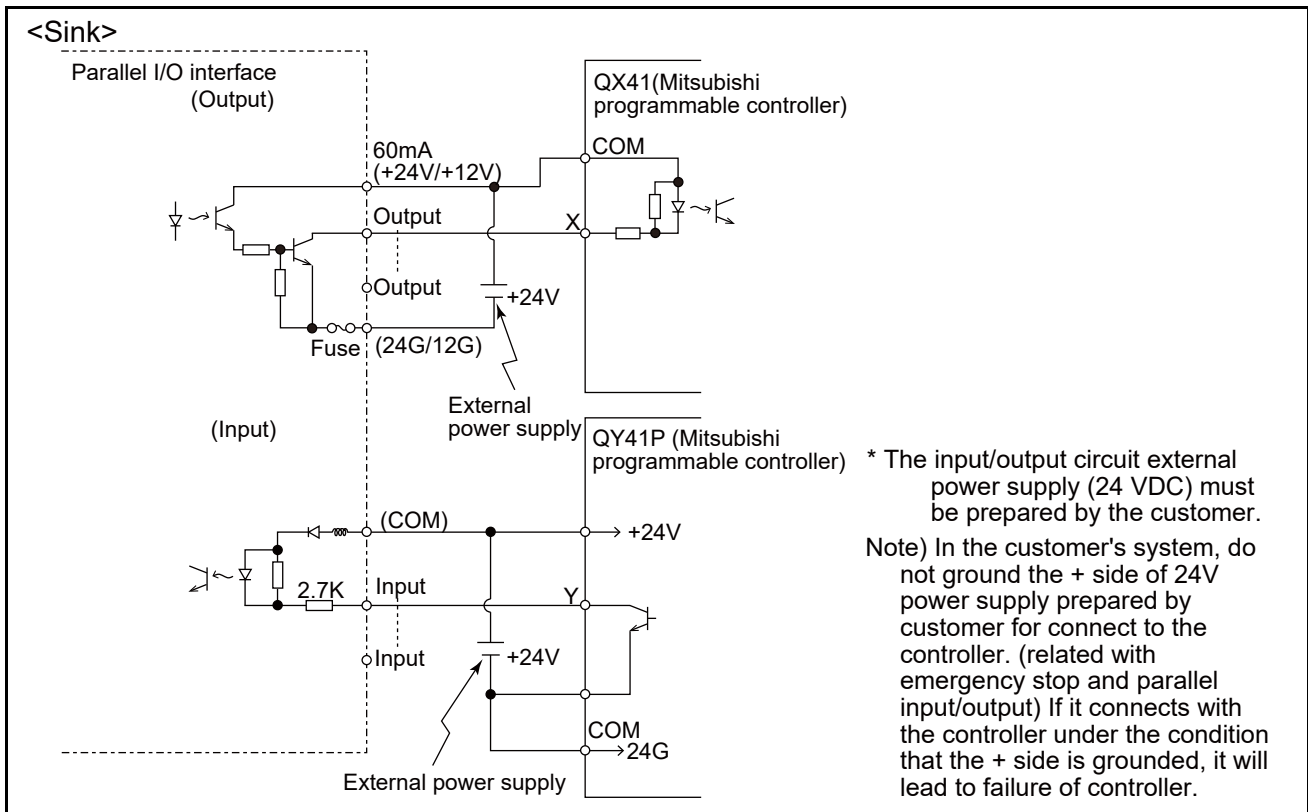

Fig.3-20: Connection with a Mitsubishi PLC (Example of sink type)

The following shows an example of a protective circuit.

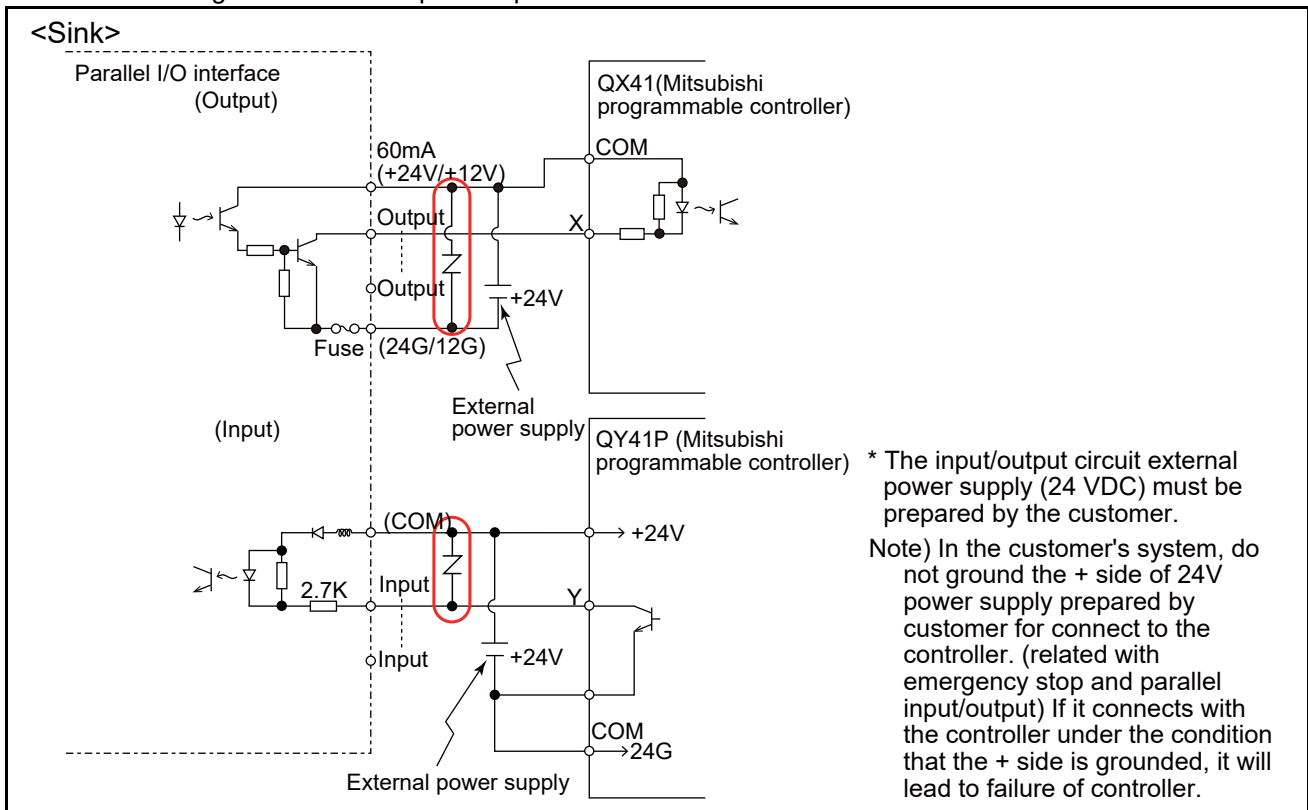

Fig.3-21: Connection with a Mitsubishi PLC (Example of sink type) for use of a protective circuit

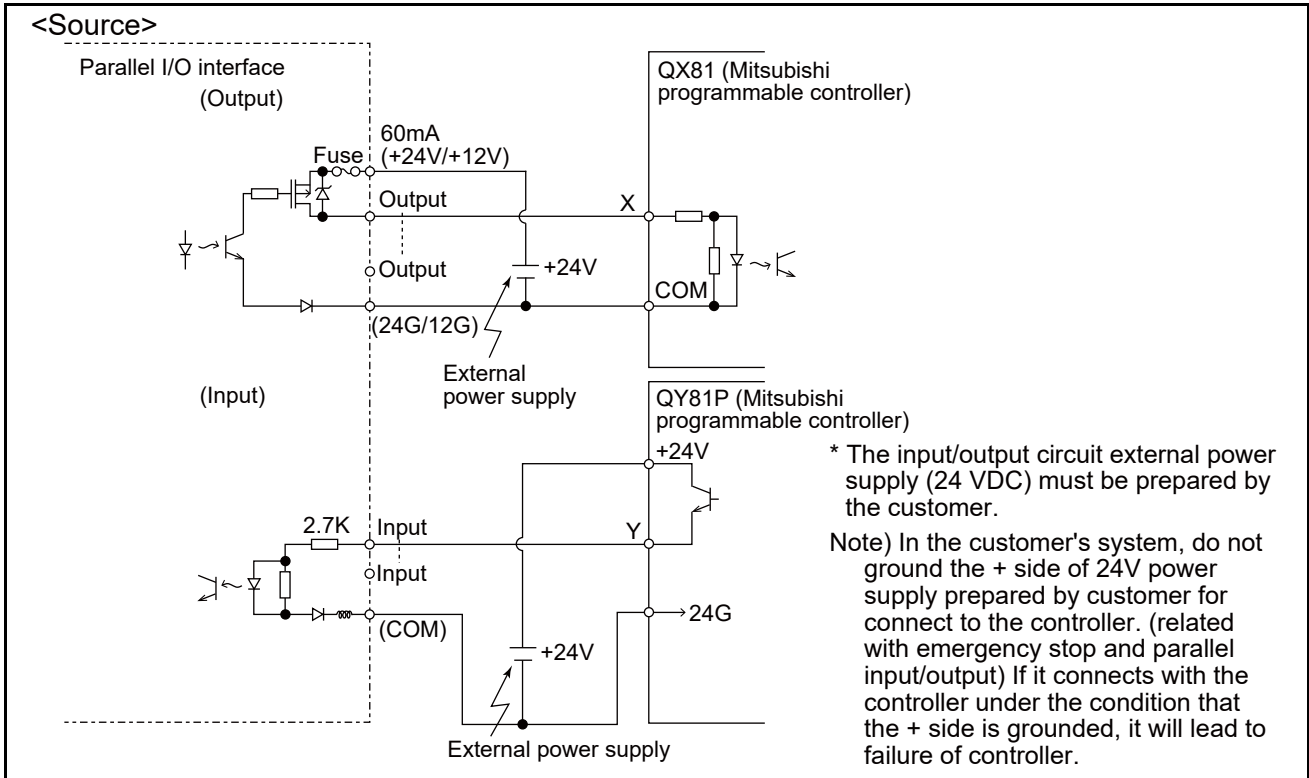

Fig.3-22: Connection with a Mitsubishi PLC (Example of source type)

The following shows an example of a protective circuit.

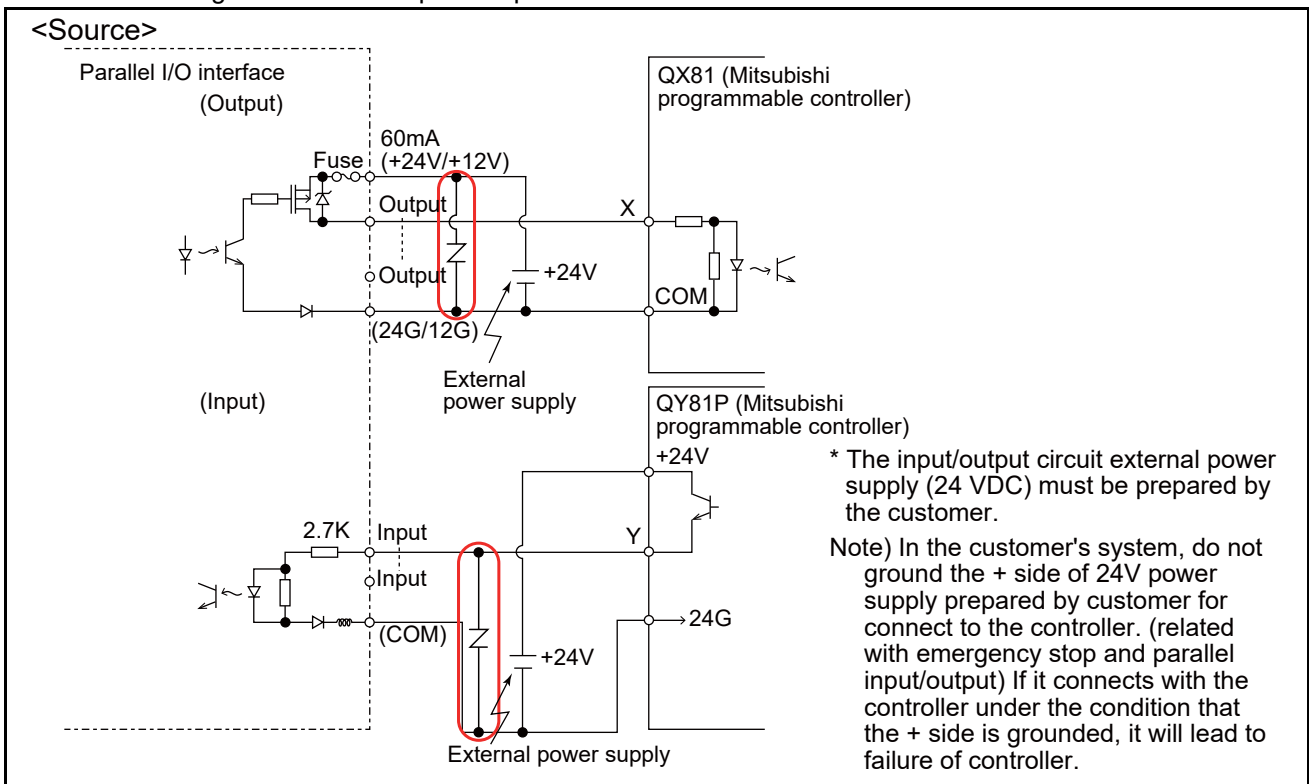

Fig.3-23: Connection with a Mitsubishi PLC (Example of source type) for use of a protective circuit

(6) External I/O cable

■ Order type : ●2D-CBL□□[Note]The numbers in the boxes□□ refer to the length. (05: 5m, 15: 15m)

■ Outline



This is the dedicated cable used to connect an external peripheral device to the connector on the parallel I/O interface.

One end matches the connector on the parallel input/output unit, and the other end is free. Connect the peripheral device's input/output signal using the free end. One cable correspond to the input 16 points and output 16 points.

Two cables are needed to connection of (input 32 points and output 32 points) with built-in standard.

■ Configuration

Table 3-22: Configuration device

Part name	Type	Qty.	Mass (kg) ^{Note1)}	Remarks
External I/O cable	2D-CBL□□	1 pc.	0.7(5m) 1.84(15m)	5m or 15m

Note1) Mass indicates one set.

■ Specifications

Table 3-23: Specifications

Items	Specifications
Number of cables x cable size	AWG #28 x 20P (40 cores)
Total length	5m, 15m

■ Connector pin numbers and cable colors

Table 3-24: Connector pin numbers and cable colors

Pin no.	Cable colors	Pin no.	Cable colors	Pin no.	Cable colors	Pin no.	Cable colors
1A/C	Orange/Red a	11A/C	Orange/Red c	1B/D	Orange/Black a	11B/D	Orange/Black c
2A/C	Gray/Red a	12A/C	Gray/Red c	2B/D	Gray/Black a	12B/D	Gray/Black c
3A/C	White/Red a	13A/C	White/Red c	3B/D	White/Black a	13B/D	White/Black c
4A/C	Yellow/Red a	14A/C	Yellow/Red c	4B/D	Yellow/Black a	14B/D	Yellow/Black c
5A/C	Pink/Red a	15A/C	Pink/Red c	5B/D	Pink/Black a	15B/D	Pink/Black c
6A/C	Orange/Red b	16A/C	Orange/Red d	6B/D	Orange/Black b	16B/D	Orange/Black d
7A/C	Gray/Red b	17A/C	Gray/Red d	7B/D	Gray/Black b	17B/D	Gray/Black d
8A/C	White/Red b	18A/C	White/Red d	8B/D	White/Black b	18B/D	White/Black d
9A/C	Yellow/Red b	19A/C	Yellow/Red d	9B/D	Yellow/Black b	19B/D	Yellow/Black d
10A/C	Pink/Red b	20A/C	Pink/Red d	10B/D	Pink/Black b	20B/D	Pink/Black d

Notes) Pin number of connector<1> are 1C, 2C, ...,20C, 1D, 2D, ...,20D, connector<2> are 1A, 2A, ...,20A, 1B, 2B, ...,20B.

■Connections and outside dimensions

The sheath of each signal cable (40 lines) is color indicated and marked with dots. Refer to the cable color specifications in "Table 3-24: Connector pin numbers and cable colors" when making the connections.

(Eg.) Pin number: color indication

1 : Orange / Red / a

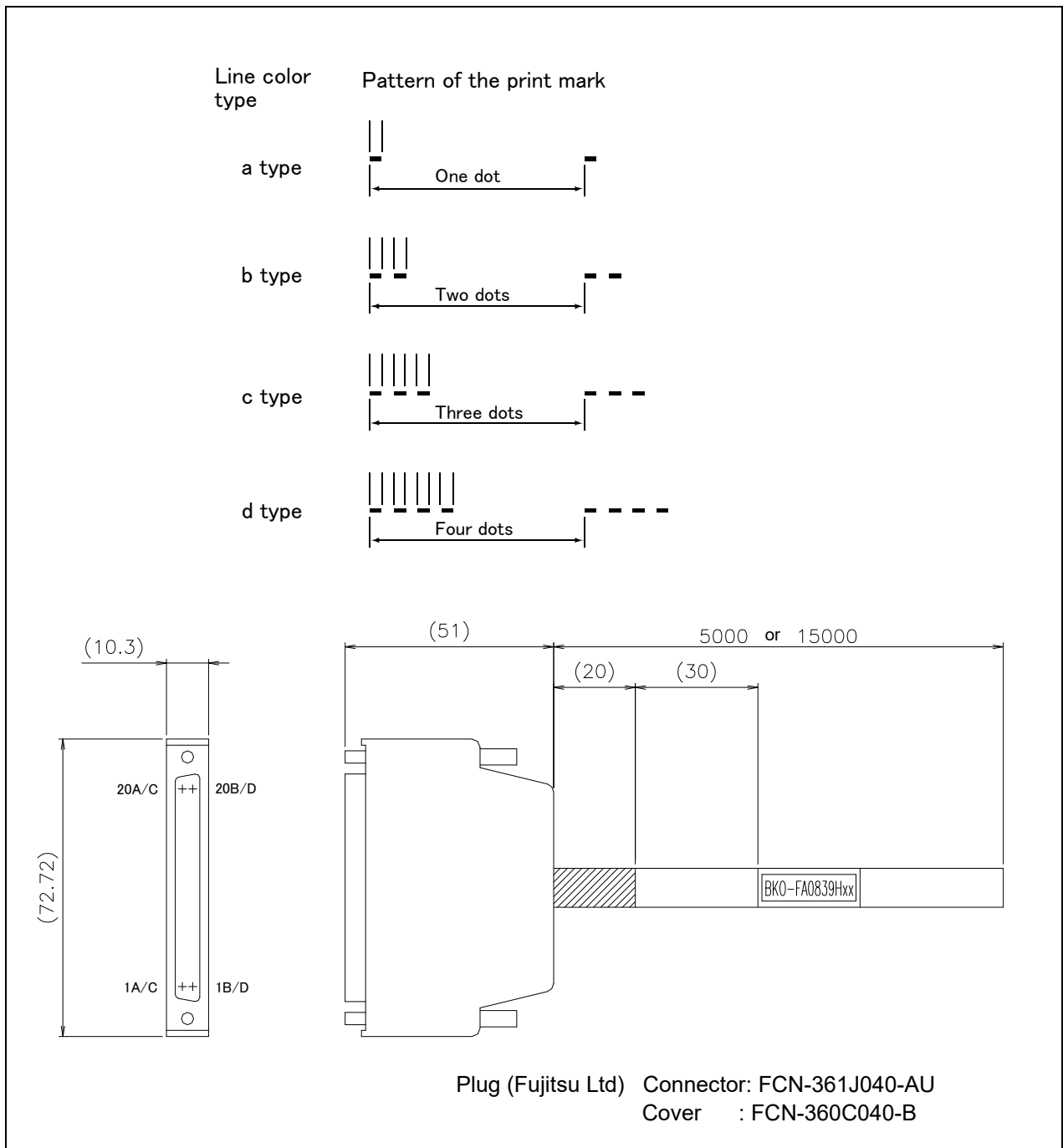
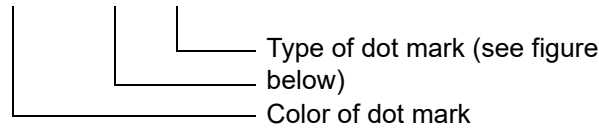

Fig.3-24: Connections and outside dimensions

(7) CC-Link interface

■Order type: ●2D-TZ576

■Outline



The CC-Link interface is the option interface to not only add bit data to the robot controller, but also to add CC-Link field network function that allows cyclic transmission of word data.

■Configuration

Table 3-25: Configuration device

Part name	Type	Qty.	Mass(kg) ^{Note1)}	Remarks
CC-Link interface	TZ576	1	0.6	
Manual	BFP-A8634	1	-	CD-ROM
Ferrite core	E04SR301334	2	-	Be sure to install this for noise countermeasure.
Cable clamp	AL4	2	-	
	AL5	2	-	
On-line connector for communication	A6CON-LJ5P	1	-	
Terminal resistor	A6CON-TR11N	1	-	Resistance value: 100Ω
One-touch connector plug for communication	A6CON-L5P	2	-	

Note1) Mass indicates one set.

Table 3-26: Procured by the customer

Part name	Type	Qty.	Remarks
Master station	FX3U-16CCCL-M (FX series)	1	
	RJ61BT11 (R series)		
	QJ61BT11 (Q series)		
	QJ61BT11N (Q series)		
	AJ61QBT11 (QnA series)		
	A1SJ61QBT11 (QnAS series)		
	AJ61BT11 (A series)		
	A1SJ61BT11 (AnS series)		
	A80BD-J61BT11 (personal computer board)		
Communication cable	-	1	Ddedicated cable

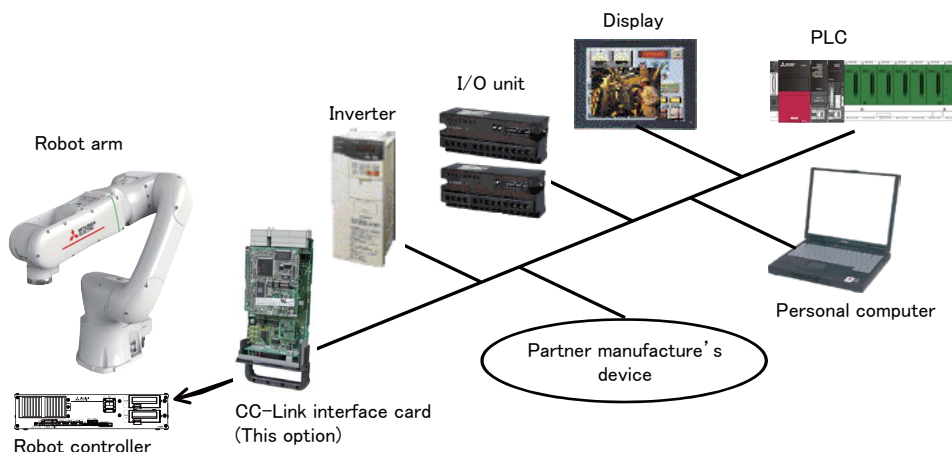

Fig.3-25: Example of CC-Link Product Configuration

■ Specifications

Table 3-27: Specifications

Item		Specifications					Remarks
Communication function		Bit data and word data can be transmitted.					Word data are used by the registers.
Station type		Intelligent device station ^{Note1)}					
Support station		Local station					No master station function
The version corresponding to CC-Link		Ver.2					The extended cyclic setup is possible.
Mountable option slot		Slot 1, 2					
Number of mountable CC-Link interface cards		1					Multiple CC-Link interface cards cannot be inserted.
Number of stations		1 to 64 stations					When four stations are occupied, continuous station numbers are used. The station numbers are set by a DIP switch.
Transmission speed		10M/5M/2.5M/625K/156K bps					This is set by the rotary SW.
Station number		1 to 64					When two or more stations are occupied, continuous station numbers are used.
Number of occupied stations		1/2/3/4					
Extended cyclic setup		1/2/4/8					
Maximum link point	Remote I/O (RX, RY).	Each 896 points					The two last cannot be used.
	Remote register (RW _r , RW _w)	Each 128 register					
Extended cyclic setup	-	1 fold setup	2 fold setup	3 fold setup	4 fold setup		
Link point per set	When one station is occupied	Remote I/O (RX, RY).	32 point	32 point	64 point	128 point	
		Remote register (RW _w)	4 word	8 word	16 word	32 word	
		Remote register (RW _r)	4 word	8 word	16 word	32 word	
	When two stations is occupied	Remote I/O (RX, RY).	64 point	96 point	192 point	384 point	
		Remote register (RW _w)	8 word	16 word	32 word	64 word	
		Remote register (RW _r)	8 word	16 word	32 word	64 word	
	When three stations is occupied	Remote I/O (RX, RY).	96 point	160 point	320 point	640 point	
		Remote register (RW _w)	12 word	24 word	48 word	96 word	
		Remote register (RW _r)	12 word	24 word	48 word	96 word	
	When four stations is occupied	Remote I/O (RX, RY).	128 point	224 point	448 point	896 point	
		Remote register (RW _w)	16 word	32 word	64 word	128 word	
		Remote register (RW _r)	16 word	32 word	64 word	128 word	
Number of the maximum occupancy station		4 stations					
The I/O first number of the robot controller.		No. 6000 - The number corresponding to the station number by the setup of the parameter "CCFIX."					

Note1) Not available for the transient transmission function and FX-series models that do not support intelligent devices.

■Functions**(1) Communication function**

- The number of usable points is 896 points maximum for bit control and 128 points maximum for word control.

(2) Easy setup

- The CC-Link interface card can be set by a rotary switch or DIP switch.
- No separate space is required to mount the CC-Link interface card as it is embedded in the robot controller (can only be mounted into slot 2).
- Easy wiring since only four terminals need to be connected.
- Dedicated commands have been added to MELFA-BASIC VI (robot programming language); thus, no complex interface programming is required.

(3) High-speed response

- The link scan time when connecting 64 stations is approximately 7.2 ms.
- A transmission speed can be selected from 10M, 5M, 2.5M, 625K and 156K bps according to the transmission distance.

(8) SD memory card
■Order type: 2F-2GBSD

■Outline



This card is used as an extended memory.
To save logging data, insert an SD card into the SD card slot on the front of the robot controller.

■Configuration

Table 3-28: Configuration device

Part name	Type	Qty.	Remarks
SD memory card	2F-2GBSD	1	Memory card capacity: 2GB

(9) Easy-setup kit

- Order type: ● 4F-ASSISTA-SETUP-JP (For Japan/North America)
● 4F-ASSISTA-SETUP-EU (For Europe/China)

■ Outline

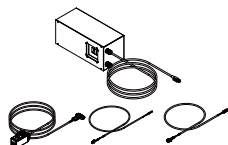

The Easy-setup kit is manufactured from the emergency stop switch, safety extension unit power supply, cables, and other devices shown in [Table 1-1](#).

■ Configuration

Table 3-29: Product configuration

Part name	Type	Qty.	Mass (kg)	Remarks
Easy-setup kit (For Japan/North America)	4F-ASSISTA- SETUP-JP	1	6.1	Plug type A for 100 V power supply
EMG / Mode selector switch box	-	1	0.48	Equipped with an emergency stop switch and a mode selector switch. (Door switch short-circuited)
SDIO cables for the safety extension unit	-	1	0.78	SDI cable: 8 SDO cable: 2
Earth leakage breaker / safety extension unit power supply box	-	1	4.84	24 V DC power supply: 1 24 V DC power input cable: 1 24 V DC power output cable: 1 Earth leakage breaker: 1 Primary power wire (Plug type A): 1
Easy-setup kit (For Europe/China)	4F-ASSISTA- SETUP-EU	1	6.1	Plug type SE for 200 V power supply
EMG / Mode selector switch box	-	1	0.48	Equipped with an emergency stop switch and a mode selector switch. (Door switch short-circuited)
SDIO cables for the safety extension unit	-	1	0.78	SDI cable: 8 SDO cable: 2
Earth leakage breaker / safety extension unit power supply box	-	1	4.84	24 V DC power supply: 1 24 V DC power input cable: 1 24 V DC power output cable: 1 Earth leakage breaker: 1 Primary power wire (Plug type SE): 1

■ Outside dimensions

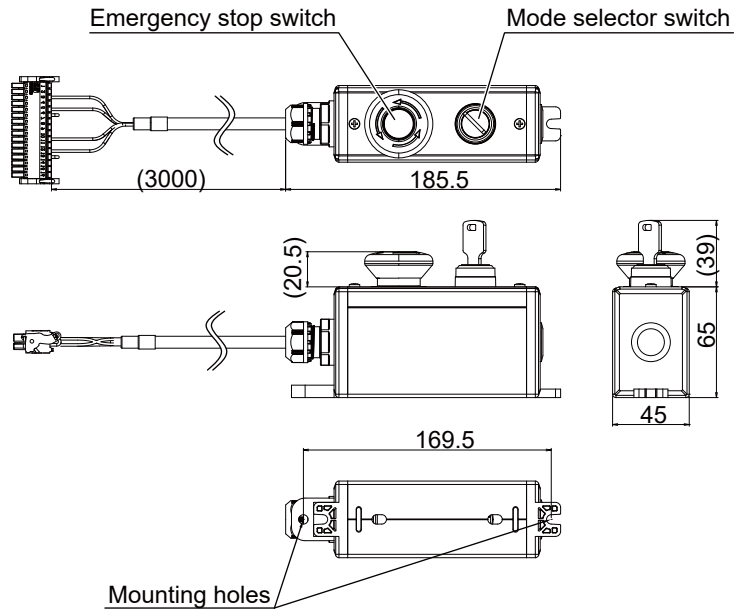

Fig.3-26: Dimensions of the EMG / Mode selector switch box

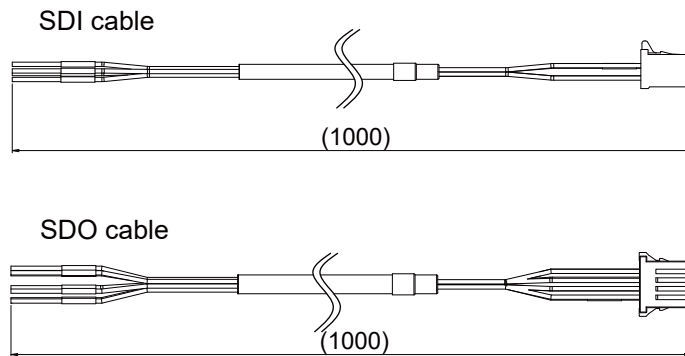

Fig.3-27: Dimensions of SDIO cables for the safety extension unit

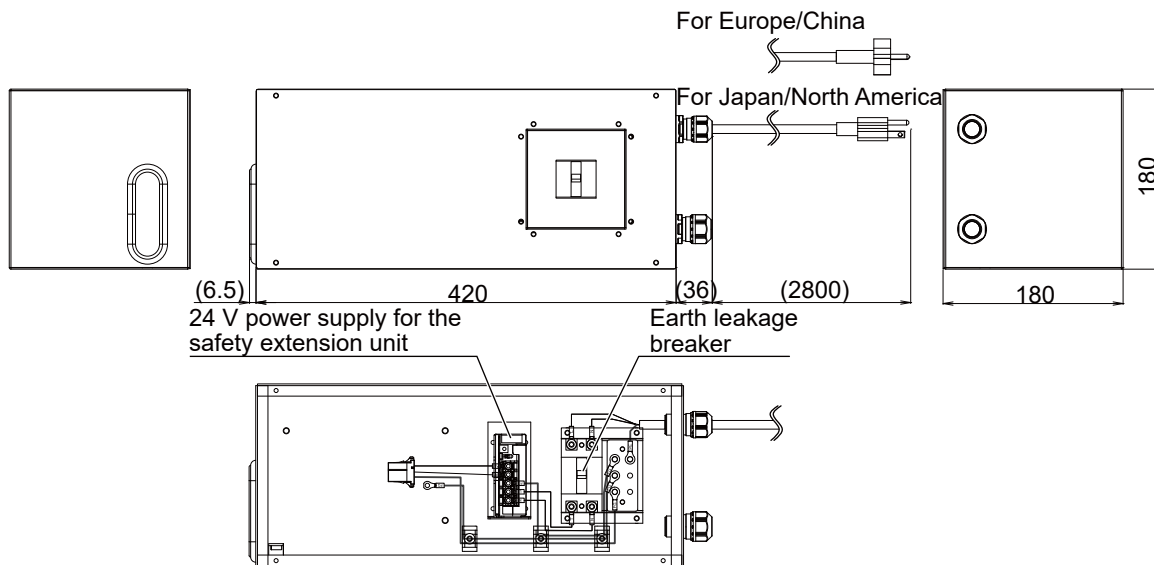

Fig.3-28: Dimensions of the Earth leakage breaker / safety extension unit power supply box

3.8 Maintenance parts

The consumable parts used in the controller are shown in [Table 3-30](#). Purchase these parts from your dealer when required. Some Mitsubishi-designated parts differ from the maker's standard parts. Thus, confirm the part name, robot arm and controller serial No. and purchase the parts from your dealer.

Table 3-30: Controller consumable parts list

No.	Name	Type ^{Note1)}	Qty.	Usage place	Supplier
1	Filter	BKOFA0773H42	1	Inside the filter cover	Mitsubishi Electric











Note1) Confirm the robot arm serial No., and contact the dealer or service branch of Mitsubishi Electric Co., for the type.

4 Software

4.1 List of commands

Table 4-1 shows the main program blocks used in RT VisualBox and their descriptions.

Table 4-1: Program block list

Program block	Block name	Description
	Move	Moves the robot (Tap/click to configure settings)
	Hand	Opens/closes the hand (Tap/click to configure settings)
	Wait	Instructs the robot to wait (Tap/click to configure settings)
	Signal	Outputs signals (Tap/click to configure settings)
	Calculate	Performs calculations (Tap/click to configure settings)
	Vision	Recognizes the workpiece (Tap/click to configure settings) This block becomes available when a robot is connected to the software.
	Pause	Pauses the operation
	Branch	Branches conditions (Tap/click to configure settings)
	Repeat	Repeats the operation (Tap/click to configure settings)
	Pallet	Used to set up palletizing operations (Tap/click to configure settings).

5 Instruction Manual

5.1 The details of each instruction manuals

The contents and purposes of the documents enclosed with this product are shown below.
Use these documents according to the application.

Manual name	Description	Manual No.
Collaborative Robot Safety Manual	To ensure the safety of robot users, this manual provides information on common precautions and safety measures that should be taken when handling the robot or creating and designing robot systems. Read this manual first.	BFP-A3733
Hello ASSISTA Quick Set-up Guide	Describes procedures including unpacking, installation, programming using RT VisualBox, and operation of the robot.	BFP-A3715
Standard Specifications Manual (This manual)	Provides information on standard product specifications, options, and maintenance parts. It also provides information on safety and technical precautions when introducing the robot into a new environment.	BFP-A3727
Robot Arm Setup and Maintenance	Explains pre-operation requirements for the robot (unpacking, transportation, installation, and operation checks) and how to carry out maintenance and inspection.	BFP-A3729
Controller Setup and Maintenance	Explains the steps that must be taken before using the robot controller (unpacking, transportation, and installation). It also contains information on maintenance and inspection.	BFP-A3731
Collaborative Robot: Detailed explanations of functions and operations	Provides information on functions specific to collaborative robots.	BFP-A3735
Detailed explanations of functions and operations ^{Note1)}	Describes details on functions and operation methods, including information of how to use MELFABASIC VI commands in programs, how to connect external input/output devices, and how to set parameters. The FR series is used as an example for explanation purposes. For information on unsupported functions, refer to the Collaborative Robot: Detailed explanations of functions and operations.	BFP-A3478
Troubleshooting ^{Note1)}	Provides information on the causes and solutions to errors that may occur while operating the robot.	BFP-A3480
Tracking Function ^{Note1)}	Provides information on the specifications, functions, and usage of the conveyor tracking function.	BFP-A3520
GOT Direct Connection Extended Function ^{Note1)}	Describes the data configuration of the memory between the GOT and the robot, monitoring, and operating procedures.	BFP-A3546
Ethernet Function ^{Note1)}	Explains how to communicate with a computer over Ethernet using TCP/IP protocols.	BFP-A3379

Note1) Instances where the CR800-D controller is mentioned also refer to the CR800-05VD.

6 Safety

6.1 Safety

For information on safety, refer to the Collaborative Robot Safety Manual and take appropriate measures accordingly.

6.1.1 Self-diagnosis stop functions

This robot has the self-diagnosis stop functions shown in [Table 6-1](#) and the stop functions shown in [Table 6-2](#) for safe use.

Table 6-1: Self-diagnosis stop functions

No.	Function	Details	Remarks
1	Overload protection function	Activates when the total servo current time exceeds the specified value.	The drive circuit is shut off. The robot stops, and an alarm displays.
2	Overcurrent diagnosis function	Activates when an overcurrent flows to the motor circuit.	The drive circuit is shut off. The robot stops, and an alarm displays.
3	Encoder disconnection diagnosis function	Activates when the encoder cable is disconnected.	The drive circuit is shut off. The robot stops, and an alarm displays.
4	Deflection over diagnosis function	Activates when an error occurs between the command value and actual position, and the error exceeds the specified amount.	The drive circuit is shut off. The robot stops, and an alarm displays.
5	AC power voltage drop diagnosis function	Activates when the AC power voltage drops below the specified value.	The drive circuit is shut off. The robot stops, and an alarm displays.
6	CPU error detection function	Activates when an error occurs in the CPU.	The drive circuit is shut off. The robot stops, and an alarm displays.
7	Overrun prevention function	Software limit detection This is the limit provided by the software to enable operation only in the operation range.	The drive circuit is shut off. The robot stops, and an alarm displays.

Table 6-2: List of stop functions

Stop function	Teaching pendant	External input	Operation buttons	Details
Emergency stop	○	○	-	The servo power is shut off and the mechanical brakes activate to stop the robot by stopping operation in an emergency. To recover, reset the alarm, and turn the servo ON with the servo ON command.
Stop	○	○	○	The robot immediately decelerates to stop by stopping operation as usual. Note that the servo power is not shut off. Use this when using the collision evasion sensor, etc.

6.1.2 External I/O signals that can be used for preventative safety measures

Table 6-3: External I/O signals that can be used for preventative safety measures

Signal	Connection point	Parameter	Functions	Usage method	
Input	External emergency stop <small>Note1)</small>	Connector CNUSR11	-	This servo power is shut off, and the robot stops immediately.	Externally installed emergency stop switch. Stopping at high-level error occurrence.
	Door switch input <small>Note1)</small>		-		Machine guard door switch.
	Stop	I/O interface	STOP, STOP2	The program execution is stopped, and the robot stops. The servo power is not shut off.	The robot is stopped when a peripheral device fault occurs. The servo power is not shut off.
	Servo OFF		SRVOFF	The servo power can be shut off.	The robot is stopped when a peripheral device fault occurs. The servo power is also shut off.
	Automatic operation enable		AUTOENA	Disables automatic operation when inactive.	Door switch on safety protection fence.
	Safety input 1	Connector SDI1 (Safety extension unit)	-	Switches between collaborative operation mode and high-speed operation mode.	By connecting a safety sensor to this input, it is possible to make the robot switch to high-speed operation mode once someone leaves the vicinity of the robot. The robot can also be made to switch to collaborative operation mode when someone nears the robot.
Output	Emergency stop output	Connector CNUSR11	-	Outputs the input signal of external emergency stop or emergency stop switch of T/B turned on.	Display and warn the pilot lamp, the input signal of external emergency stop or the emergency stop switch of T/B turned on.
	In servo ON	I/O interface	SRVON	The servo power ON/OFF state is output.	The servo power ON/OFF state is shown and alerted with the display lamps.
	Waiting		STOP, STOP2	Outputs that the robot is temporarily stopped.	The temporary stop state is shown and alerted with the display lamps.
	In alarm	Connector CNUSR11	ERRRESET	Outputs when an alarm occurs in the robot.	The alarm state is shown and alerted with the display lamps.
	Operation status <small>Note2)</small>	I/O interface	SFMODE	Outputs the operation status (high-speed/standard/low-speed).	The operation status is indicated by the Status indicator LED.

Note1) The external emergency stop input and the door switch input have duplicate NC contacts for redundancy. Thus, if the emergency stop input circuit is opened when the robot is started up, the robot will not operate. Refer to [Page 98, "6.1.3 Examples of safety measures"](#) for details. And, refer to [Page 67, "\(1\) Automatic Operation/Jog Operation/Brake Release and Necessary Switch Settings"](#) for the function of the door switch input and the mode selector switch input.

Note2) Safety outputs of the safety extension unit can also output the operation status. For information on how to set this signal, refer to the Collaborative Robot: Detailed explanations of functions and operations. All output signals listed in [Table 6-3](#) are non-safety output. If system requires safety output, please use that of safety extension unit.

6.1.3 Examples of safety measures

The controller's dedicated I/O terminal connector has a duplicate emergency stop circuit. A Safety extension unit must be connected to the robot.

Figures Fig. 6-1 to Fig. 6-6 are examples of safety measures. Refer to these figures when creating safety measures. The figures represent systems which are operating normally (i.e. Systems not in an emergency stop state).

[Note] • In the emergency-stop related wiring by the customer, if the coil (is not the contact points) of the relay prepared by the customer is connected to the controller, please be sure to implement the measure against the noise by the customer in the coil section. And, please also take the lifetime of noise suppression parts into consideration.

- Electric specification of the emergency-stop-related output terminal: 24V DC or less, related current 100mA or less.
- In the customer's system, do not ground the + side of 24V power supply prepared by customer for connect to the controller. (related with emergency stop and parallel input/output) If it connects with the controller under the condition that the + side is grounded, it will lead to failure of controller.

Examples of safety measures	Description	Figure
Wiring example 1	Not using a machine guard and running the robot in collaborative operation mode only	Fig. 6-1
Wiring example 2	Using a safety sensor (such as an area sensor) to switch between collaborative operation mode and high-speed operation mode	Fig. 6-2
Wiring example 3	Using a machine guard and running the robot in high-speed operation mode only	Fig. 6-3
Wiring example 4	Connecting an emergency stop switch of a peripheral device when using collaborative operation mode	Fig. 6-4
Wiring example 5	Connecting an emergency stop switch of a peripheral device to two robot controllers when using collaborative operation mode	Fig. 6-5
Wiring example 6	Connecting a safety relay to a robot controller	Fig. 6-6

<Wiring example 1>: Not using a machine guard and running the robot in collaborative operation mode only
 Connect the emergency stop switch of peripheral equipment to the controller. The power supply for emergency stop input uses the power supply in the controller.
 <Operation of the emergency stop>
 If the emergency stop switch of peripheral equipment is pushed, the robot will also be in the emergency stop state.
 <Operation of Safety input 1>
 Opening the terminals will keep the robot in collaborative operation mode.

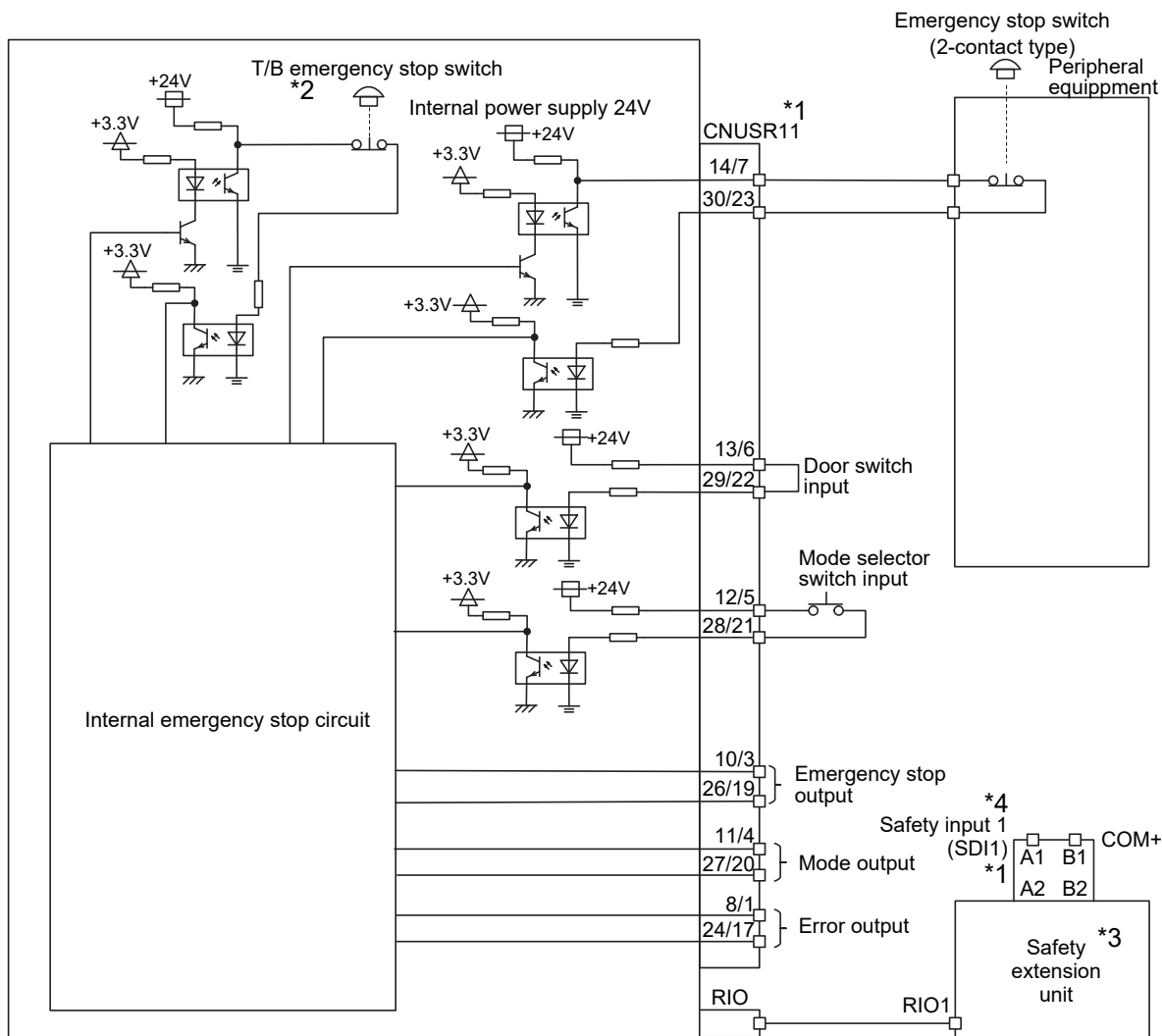

- *1) The CNUSR11 port and SDI1 port both have two rows of terminals, indicating that there are two channels. Both channels must be connected.
- *2) This is the emergency stop switch of the teaching pendant that is connected to the robot controller.
- *3) If a Safety extension unit is not connected to the robot controller, the error H2260 "Safety function execution disabled (No extended safety unit)" will occur.
- *4) For examples of safety input 1 connections, refer to the section "Connecting the safety extension unit to the controller" in the separate manual "Instruction Manual: Controller Setup and Maintenance".

Fig.6-1: Example of safety measures (wiring example 1)

<Wiring example 2>: Using a safety sensor (such as an area sensor) to switch between collaborative operation mode and high-speed operation mode
 Connect the emergency stop switch of peripheral equipment to the controller. The power supply for emergency stop input uses the power supply in the controller.
 <Operation of the emergency stop>
 If the emergency stop switch of peripheral equipment is pushed, the robot will also be in the emergency stop state.
 <Operation of Safety input 1>
 By connecting a safety sensor to this input, it is possible to make the robot switch to high-speed operation mode (safety input 1 closed) once someone leaves the vicinity of the robot. The robot can also be made to switch to collaborative operation mode (safety input 1 open) when someone nears the robot.

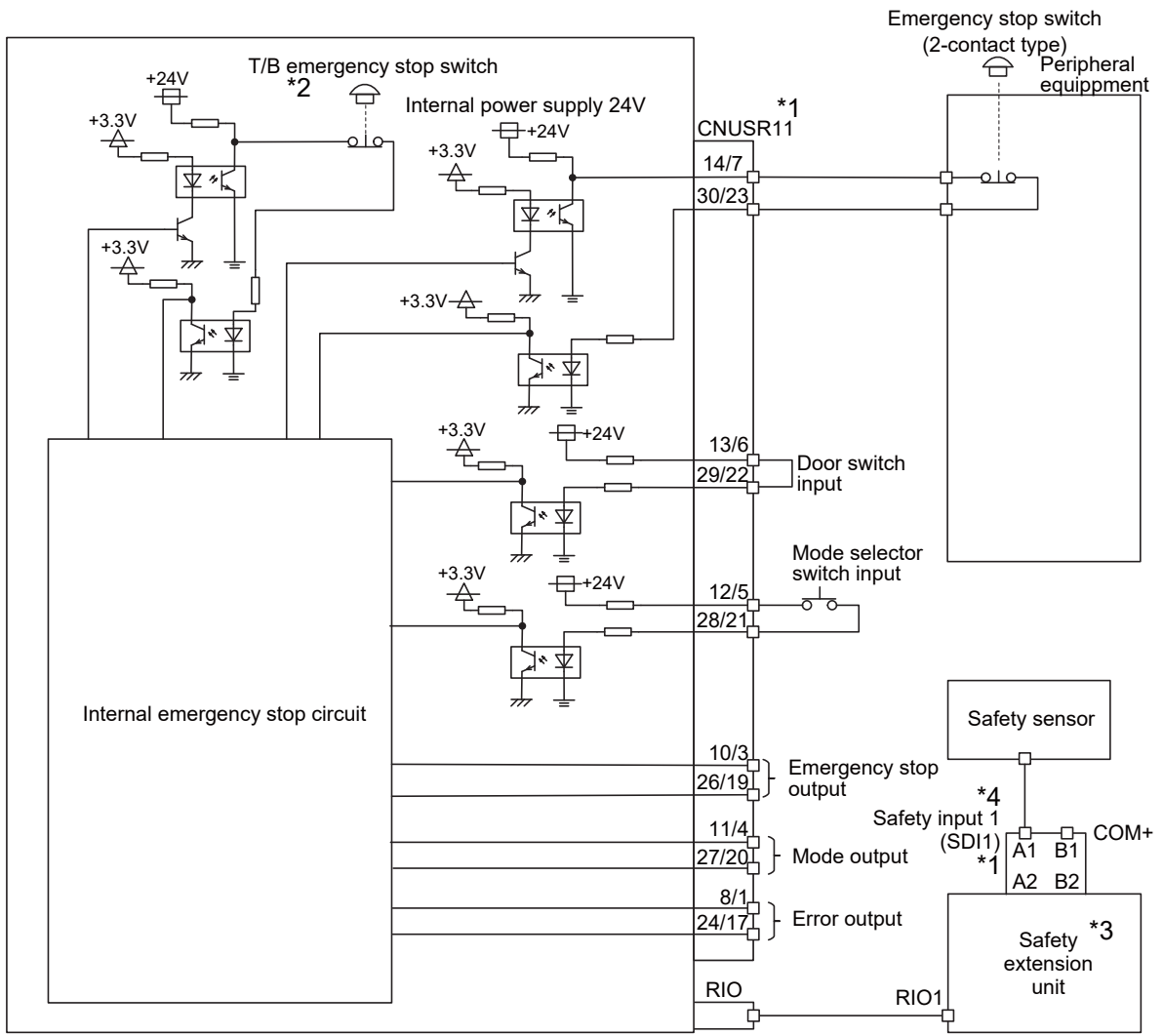

*1) The CNUSR11 port and SDI1 port both have two rows of terminals, indicating that there are two channels. Both channels must be connected.
 *2) This is the emergency stop switch of the teaching pendant that is connected to the robot controller.
 *3) If a Safety extension unit is not connected to the robot controller, the error H2260 "Safety function execution disabled (No extended safety unit)" will occur.
 *4) For examples of safety input 1 connections, refer to the section "Connecting the safety extension unit to the controller" in the separate manual "Instruction Manual: Controller Setup and Maintenance".

Fig.6-2: Example of safety measures (wiring example 2)

<Wiring example 3>: Using a machine guard and running the robot in high-speed operation mode only
 Connect the emergency stop switch of peripheral equipment to the controller. The power supply for emergency stop input uses the power supply in the controller.
 <Operation of the emergency stop>
 If the emergency stop switch of peripheral equipment is pushed, the robot will also be in the emergency stop state.
 <Operation of Safety input 1>
 Closing the terminals will keep the robot in high-speed operation mode.

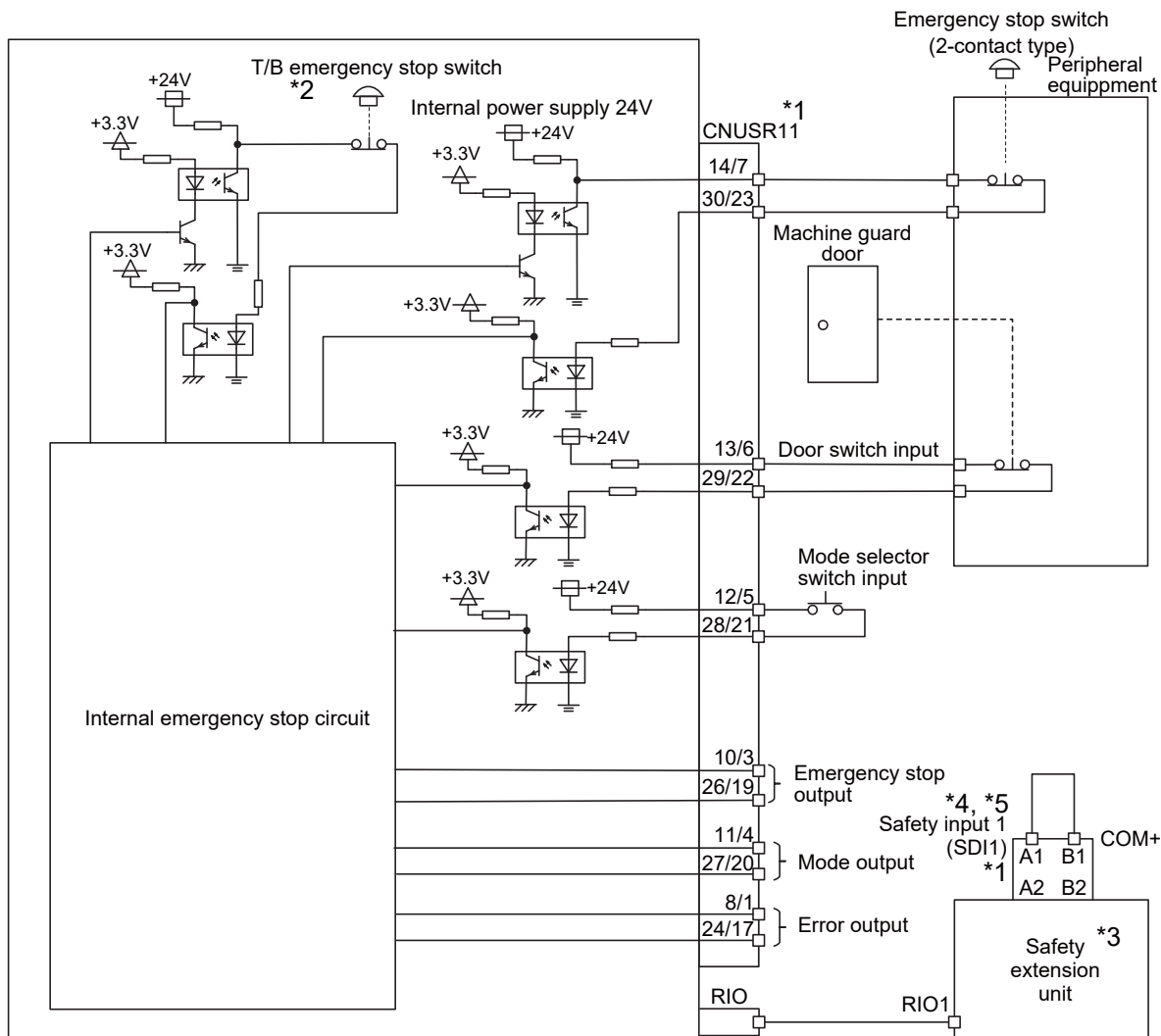

- *1) The CNUSR11 port and SDI1 port both have two rows of terminals, indicating that there are two channels. Both channels must be connected.
- *2) This is the emergency stop switch of the teaching pendant that is connected to the robot controller.
- *3) If a Safety extension unit is not connected to the robot controller, the error H2260 "Safety function execution disabled (No extended safety unit)" will occur.
- *4) For examples of safety input 1 connections, refer to the section "Connecting the safety extension unit to the controller" in the separate manual "Instruction Manual: Controller Setup and Maintenance".
- *5) Direct teaching is not available in high-speed operation mode.

Fig.6-3: Example of safety measures (wiring example 3)

<Wiring example 4>: Connecting an emergency stop switch of a peripheral device when using collaborative operation mode
 The power supply for emergency stop input uses the power supply in the controller. Monitor the emergency stop state by the peripheral equipment side.
 <Operation of the emergency stop>
 If the emergency stop switch of peripheral equipment is pushed, the robot will also be in the emergency stop state.
 When the controller power is OFF, the peripheral devices are in the emergency stop state.

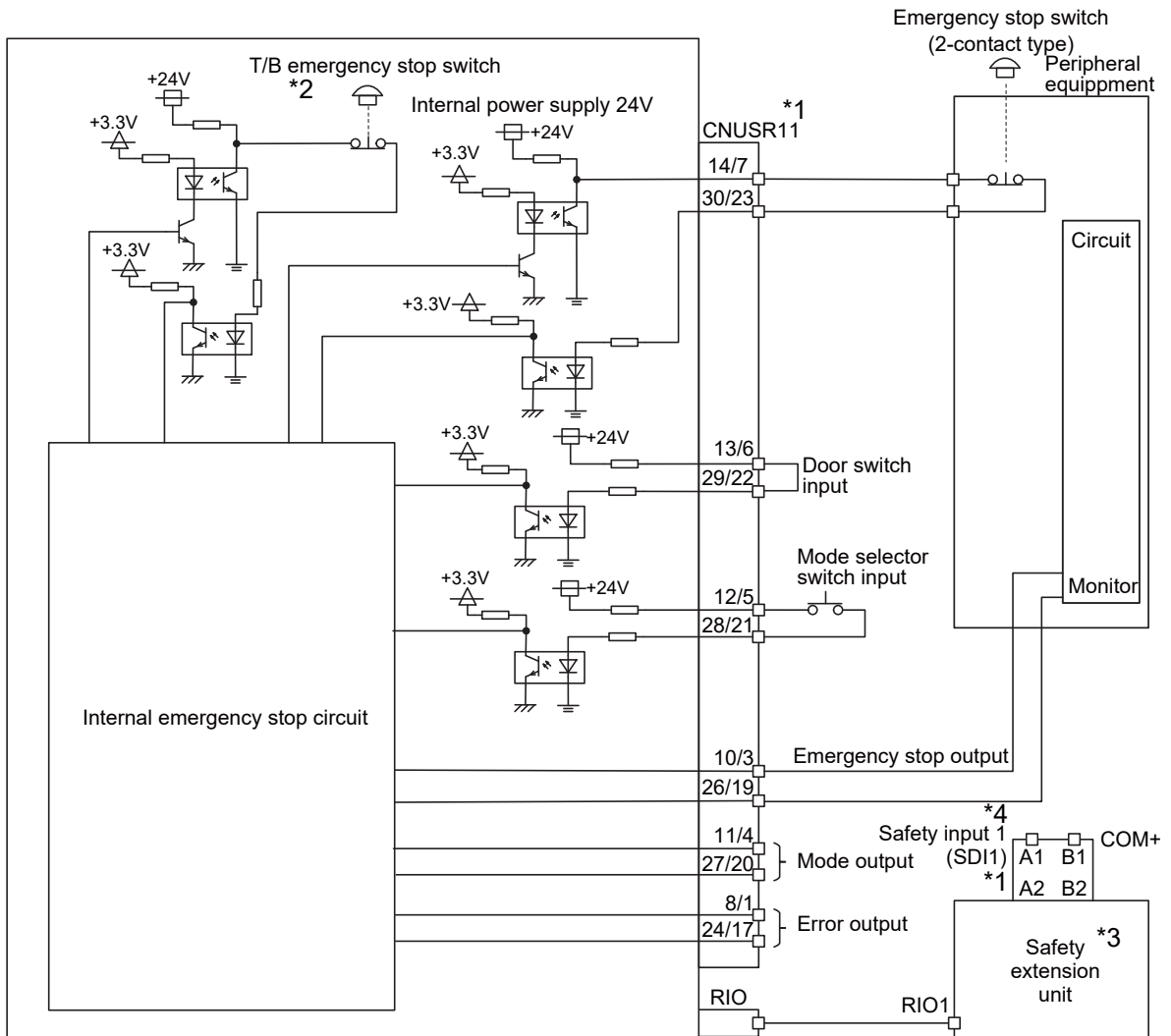

*1) The CNUSR11 port and SDI1 port both have two rows of terminals, indicating that there are two channels. Both channels must be connected.
 *2) This is the emergency stop switch of the teaching pendant that is connected to the robot controller.
 *3) If a Safety extension unit is not connected to the robot controller, the error H2260 "Safety function execution disabled (No extended safety unit)" will occur.
 *4) For examples of safety input 1 connections, refer to the section "Connecting the safety extension unit to the controller" in the separate manual "Instruction Manual: Controller Setup and Maintenance".

Fig.6-4: Example of safety measures (wiring example 4)

<Wiring example 5>: Connecting an emergency stop switch of a peripheral device to two robot controllers when using collaborative operation mode
 The power supply for emergency stop input uses the power supply in the controller. Monitor the emergency stop state by the peripheral equipment side.
 <Operation of the emergency stop>
 If the emergency stop switch of peripheral equipment is pushed, the robot will also be in the emergency stop state. When the controller power is OFF, the peripheral devices are in the emergency stop state.

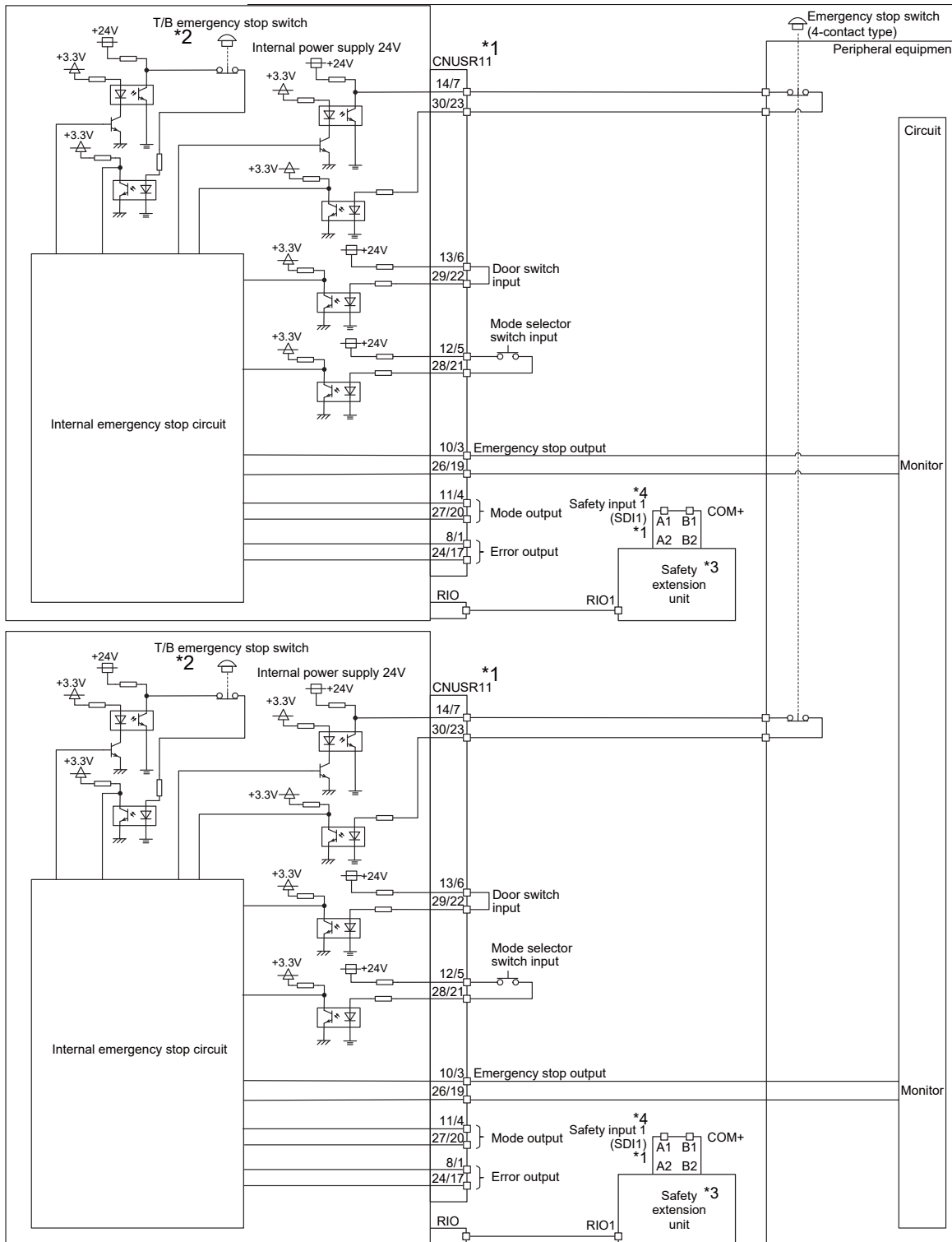

- *1) The CNUSR11 port and SDI1 port both have two rows of terminals, indicating that there are two channels. Both channels must be connected.
- *2) This is the emergency stop switch of the teaching pendant that is connected to the robot controller.
- *3) If a Safety extension unit is not connected to the robot controller, the error H2260 "Safety function execution disabled (No extended safety unit)" will occur.
- *4) For examples of safety input 1 connections, refer to the section "Connecting the safety extension unit to the controller" in the separate manual "Instruction Manual: Controller Setup and Maintenance".

Fig.6-5: Example of safety measures (wiring example 5)

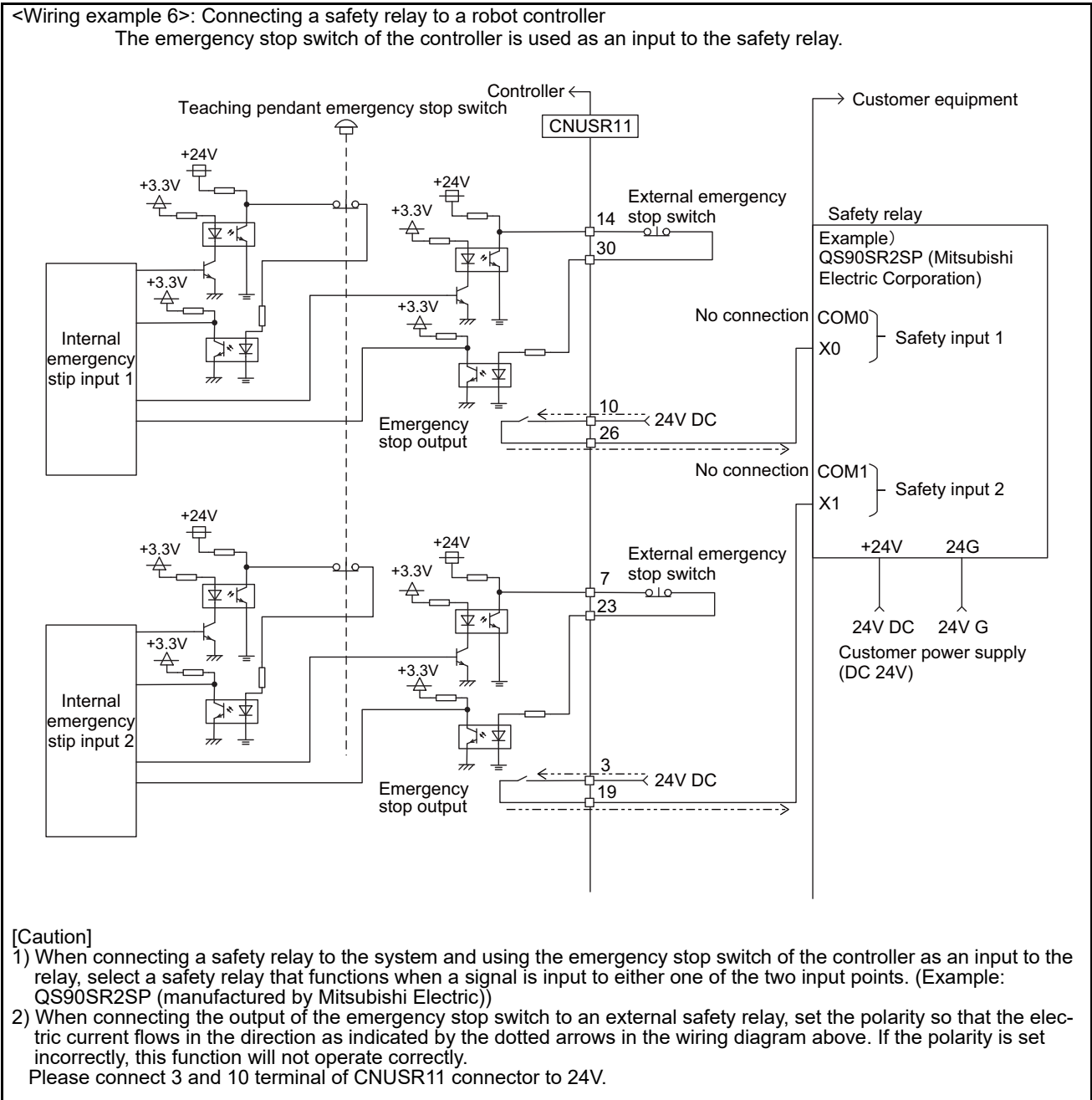

Fig.6-6: Example of safety measures (wiring example 6)

(1) External emergency stop connection [supplementary explanation]

- (1) Use a 2-contact type switch for all switches.
- (2) Install a limit switch on the doors of machine guards. Wire the switch to the Door switch input terminal so that the NO contact (Form-A) turns the terminal On when the door is closed (power applied to switch), and turns the terminal Off when the door is open (switch released).
- (3) Use an IEC 60204-1 compliant emergency stop switch, which has two NC contacts for redundancy and a mechanical latching function.
- (4) Classify the faults into minor faults (faults that are easily restored and that do not have a great effect) and major faults (faults that cause the entire system to stop immediately, and that require care in restoration), and wire accordingly.

[Caution] The external emergency-stop switch pins of the user-wired CNUSR11 connector can be used for safety measures. Please be aware that there are restrictions on the number of switch contacts, cable rating, and cable length.

- Switch contact Prepare a 2-contact type. *1)
- Switch contact capacity Related current of 24 VDC or higher for a no-voltage contact. *1)
- Cable length The length of the wire between the switch and terminal block must be max. 15m or less. Please use the shield line, in case of the cable may receive the noise etc. by other equipment, such as servo amplifier. And, if it is necessary, please fix a ferrite core (recommended model name: E04SR301334, manufacturer: Seiwa Electric Mfg. Co., Ltd.) to the shielded cable.
The size of the wire that fits to use is shown below.
CNUSR11 connector: AWG24 to 16 (0.2 to 1.25mm²)

Electric specification of the emergency stop related output circuit is 100mA/24V or less. Don't connect the equipment except for this range.

CAUTION

Be sure to perform wiring correctly. If there are mistakes in the wiring, the robot may not stop when the emergency stop button is pressed and there will be a risk of damage or personal injury occurring.

After wiring, be sure to press each of the installed emergency stop switches and check whether the emergency stop circuit works properly.

CAUTION

Be sure to duplicate connection of the emergency stop, door switch and mode selector switch. If not duplicated, these functions may fail due to a broken relay used by customer, etc.

*1) The minimum load electric current of the switch is more than 5mA/24V.

6.2 Working environment

Avoid installation in the following places as the equipment's life and operation will be affected by the ambient environment conditions. When using in the following conditions, the customer must pay special attention to the preventive measures.

(1) Power supply

- Where the voltage fluctuation will exceed the input voltage range.
- Where a momentary power failure exceeding 20ms may occur.
- Where the power capacity cannot be sufficiently secured.

CAUTION

Please use the controller with an input power supply voltage fluctuation rate of 10% or less. In the case of 200 VAC input, for example, if the controller is used with 180 VAC during the day and 220 VAC during the night, turn the servo off once and then on again.

If this is not performed, an excessive regeneration or overvoltage error may occur.

(2) Noise

- Where a surge voltage exceeding 2000V, 5kHz (equivalent to EN 61000-4-4) may be applied on the primary voltage. Locations where a strong electric field or magnetic field exists, such as near large inverters, high output frequency oscillator, large contactors and welding machines.

[Recommendation]

A noise-cut transformer; a noise filter; reinforcement of ground lines and electromagnetic shields; isolation by keeping away from noise sources; reduction of noise level of emission.

This product has undergone EMC testing for products intended for use in industrial environments (tested to standards EN 61000-6-2 and EN 61000-6-4). This product is not intended to be connected to residential, commercial, or light-industrial power supplies.

(3) Temperature and humidity

- Where the atmospheric temperature exceeds 40 degree , lower than 0 degree.
- Where the relative humidity exceeds 75% RH or below 45% RH, or condensation may occur.
- Where the robot will be subject to direct sunlight or near heat generating sources such as heaters.

(4) Vibration

- Where excessive vibration or impact may be applied. (Use in an environment of 3.5G or less during transportation and 0.1G or less during operation.)

CAUTION

If the robot is installed on equipment such as an automated guided vehicle (AGV), turn the robot servos OFF while the AGV is moving. Robot servos cannot be turned OFF with RT VisualBox.

(5) Installation environment

- Where strong electric fields or magnetic fields are generated.
- Where the installation surface is rough. (Avoid installing the robot on a bumpy or inclined floor.)
- Where there is heavy powder dust and oil mist present.

6.3 Precautions for handling

- (1) The robot has brakes. If the robot is moved with an excessive external force while the brake is applied, the robot accuracy may decrease, a backlash may occur, or the reduction gear may be damaged.
- (2) Avoid moving the robot arm by hand. When unavoidable, gradually move the arm. If moved suddenly, the accuracy may drop due to an excessive backlash, or the backed up data may be destroyed.
- (3) Note that depending on the posture, even when within the movement range, the wrist section could interfere with the base section. Take care to prevent interference during jog.
- (4) The robot arm consists of precision parts such as bearing. Lubricants such as grease are also applied on the moving parts to keep the mechanical accuracy. In a cold start under low temperature or in the first start after being stored for one month or longer, lubricants may not be spread enough. Such condition may lower the positioning accuracy, cause servo and overload alarms, and early wearing of the moving parts. To avoid such situation, perform warm-up operation of the machine at a low speed (at about 20%

of normal operation speed). Move the robot arm from the lower to the upper limit of the movable range with the 30 degree joint angle or more for about 10 minutes. After that, speed up the operation gradually.

Please use the warm-up operation. (About the details of the warm-up operation, refer to "INSTRUCTION MANUAL/Detailed explanations of functions and operations".)

- (5) The robot arm and controller must be grounded with 100Ω or less (class D grounding) to secure the noise resistance and to prevent electric shocks.
- (6) The items described in these specifications are conditions for carrying out the periodic maintenance and inspections described in the instruction manual.
- (7) If this robot interferes with the workpiece or peripheral devices during operation, the position may deviate, etc. Take care to prevent interference with the workpiece or peripheral devices during operation.
- (8) Do not attach a tape or a label to the robot arm and the controller. If a tape or a label with strong adhesive power, such as a packaging tape, is attached to the coated surfaces of the robot arm and controller, the coated surface may be damaged when such tape or label is peeled off.
- (9) If the robot is operated with a heavy load and at a high speed, the surface of the robot arm gets very hot. It would not result in burns, however, it may cause secondary accidents if touched carelessly.
- (10) Do not shut down the input power supply to stop the robot. If the power supply is frequently shut down during a heavy load or high-speed operation, the speed reducer may be damaged, backlash may occur, and the program data may be destroyed.
- (11) If something collides with body of the robot while it is in automatic operation mode (due to the origin being set incorrectly, for example), the casing or mechanisms such as reduction gears may need to be replaced. Contact Mitsubishi Electric or your local distributor for replacement parts. Continued use of the robot after a collision without inspecting or changing parts will increase the risk of damaging reduction gears or other mechanisms.
- (12) If power is interrupted the brakes will be applied. In which case, the arm may deviate from its original path if it is in automatic operation mode. Depending on the movement the robot is making at the time the power is interrupted, the robot arm may come into contact with the body of the robot. Take measures to ensure that dangerous situations do not arise from the arm interfering with peripherals.
Example) Installing a UPS (uninterruptible power supply unit) to the primary power source in order to reduce interference.
- (13) Do not conduct an insulated voltage test. If conducted by mistake, it may result in a breakdown.
- (14) Fretting may occur on the axis which moving angle or moving distance move minutely, or not moves. Fretting is that the required oil film becomes hard to be formed if the moving angle is small, and wear occurs. The axis which not moved is moving slightly by vibration etc. To make no fretting recommends to move these axes about once every day the 30 degree or more, or the 20mm or more.
- (15) The United Nations' Recommendations on the Transport of Dangerous Goods must be observed for transborder transportation of lithium batteries by air, sea, and land. The lithium batteries (ER6V) used in Mitsubishi industrial robots contain lithium and fall under the definition.
When the lithium batteries are shipped for storage, etc., they will be classified as Class 9: Miscellaneous dangerous substances and articles. Please contact your transportation company and must provide appropriate transport safety measures as the customer's consignor.
- (16) If the air supply temperature (primary piping) used for the tool etc. is lower than ambient air temperature, the dew condensation may occur on the coupling or the hose surface.
- (17) When fumigants that contain halogen materials such as fluorine, chlorine, bromine, and iodine are used for disinfecting and protecting wooden packaging from insects, they cause malfunction when entering our products. Please take necessary precautions to ensure that remaining materials from fumigant do not enter our products, or treat packaging with methods other than fumigation (heat method). Additionally, disinfect and protect wood from insects before packing products.

6.4 EMC installation guideline

6.4.1 Outlines

Industrial robots are one of the components of automation systems as well as main components. This section introduces methods and parts to ensure electromagnetic compatibility (EMC) in automation systems.

We test for EMC in the environment described in this manual, but the noise level varies depending on device types, layout, control panel structure, and wiring, etc. Please make final checks for EMC.

6.4.2 EMC

EMC can be broadly classified into two categories: EMI and EMS.

(1) Emission (EMI: Electromagnetic Interference).....The capacity not to generate the disturbance noise which has a bad influence outside.

(2) Immunity (EMS: Electromagnetic Susceptibility)....The capacity which does not malfunction for the disturbance noise from the outside.

Each contents are shown below.

Item	Name	Contents
Emission (EMI)	Radiative noise disturbance	The electromagnetic noise etc. which are emitted to environments.
	Electrical-conduction noise disturbance	The electromagnetism noise etc. which flow out of the power-supply line.
Immunity (EMS)	Electrostatic discharge immunity test	The noise from the electrified human body.
	Radiated, radio-frequency, electromagnetic field immunity test susceptibility test	The electromagnetism noise from the transceiver, the broadcasting station, etc.
	Electrical fast transient burst immunity test	The relay noise or the electromagnetism noise etc. which are caused in power-supply ON/OFF.
	Immunity to conducted disturbances induced radio-frequency fields	The electromagnetism noise etc. which flow in through the power source wire and the grounding wire.
	Power frequency magnetic field immunity test	The electromagnetism noise with a power supply frequency of 50/60 Hz etc.
	Voltage dips, short interruptions and voltage variations immunity test	The noise in the variation of the source voltage of the power dispatching, etc.
	Surge immunity test	The electromagnetism noise by the thunderbolt, etc.

6.4.3 EMC measures

There are mainly following items in the EMC measures.

- (1) Store into the sealed metal board.
- (2) Grounding all the conductor that have floated electrically (makes the impedance low).
- (3) Wiring so that the power source wire and signal wire are separated.
- (4) Use the shield cable for the cable which wired outside of the metal board.
- (5) Install the noise filter.

To suppress the noise emitted out of the board, be careful of the following item.

- (1) Ensure grounding of the equipment.
- (2) Use the shield cable.
- (3) Separate the metal board electrically. Narrows the distance/hole.

The strength of electromagnetic noise emitted to environment is changed a lot by the shielding efficiency of cable and the distance of metal board, so it should be careful.

6.4.4 Example of EMC measures

Industrial robots are designed for use with other devices. We test our industrial robots for conformity with EMC standards in the following system architecture. However, it does not mean that every system meets the requirements of EMC standards.

Electromagnetic compatibility depends on the relationship between the industrial robot and devices in the system, wiring conditions, layout, or other factors. Therefore, check whether the entire machinery/system meets the requirements.

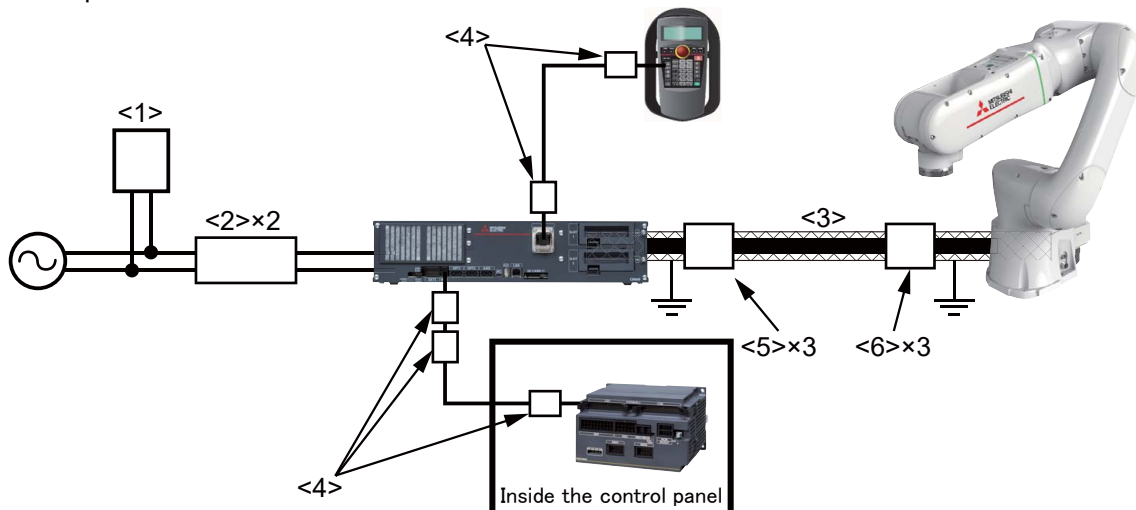

Fig.6-7: Example of EMC measures

- 1) Attach the shield tube <3> to the machine cable and ground both ends of the tube.
- 2) Install the ferrite cores <5> and <6> on the shield tube.
- 3) Install the ferrite cores <4> on the cable of the teaching pendant.
- 4) Attach the noise filters <2> and surge protector <1> to the power cable.
- 5) Install the ferrite cores <4> on the RIO cable of the safety extension unit.

Table 6-4: Parts for EMC measures

No.	Item	Model	Quantity	Manufacturer	Remarks
1	Surge protector	RSPD-250-Q4	1	OKAYA ELECTRIC INDUSTRIES CO., LTD.	-
2	Noise filter	SUP-EL15-ER6	2	OKAYA ELECTRIC INDUSTRIES CO., LTD.	-
3	Shield tube	MTFX40	1	Zippertubing (Japan), Ltd.	-
4	Ferrite core	E04SR301334	5	SEIWA ELECTRIC MFG CO.Ltd	-
5	Ferrite core	GTFC41-27-16	3	KITAGAWA INDUSTRIES CO.,LTD.	Install them on the shield tube.
6			3		

6.4.5 Parts for EMC measures

For details on the parts for EMC measures described on [Page 109, "6.4.4 Example of EMC measures"](#), contact your nearest Mitsubishi branch or dealer.

7 Appendix

Appendix 1: Inertia calculation method

An allowable moment of inertia in the mechanical interface at the tip of the robot arm is determined. If a load exceeding the allowable moment of inertia is put, on the tip of the arm, vibration during operation and an overload alarm may occur. Therefore, consider the matching/appropriateness of the hand and load to be mounted on the tip of the arm for the robot specifications when you select a robot. The following describes the load inertia calculation method.

For the vertical multi-joint robot, consider the load moment and the load inertia on the wrist axes (J4 to J6 axes). To consider them, calculate the load moment and load inertia applied on each of J4 to J6 axes in consideration of the posture of the hand and workpiece. The following figures show the examples.

(1) Load moment calculation example (for J5 axis with flange facing downwards)

The items shown in the right picture are defined as follows.

Hand mass : W_1 (kg)

Center of gravity of the hand : L_1 (m)

Workpiece mass : W_2 (kg)

Center of gravity of the workpiece : L_2 (m)

The load moment applied to the J5 axis is calculated as follows.

Where g is gravitational acceleration (m/s^2).

$$\begin{aligned} \text{Load moment about the J5 axis : } M \text{ (Nm)} \\ = W_1 \times L_1 \times g + W_2 \times L_2 \times g \end{aligned}$$

Check that the value of M is equal to or less than the allowable load moment of the target model.

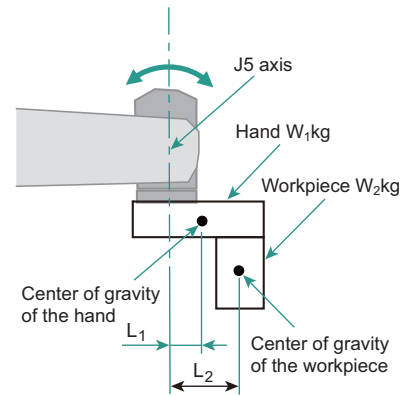

(2) Load inertia calculation example (for J6 axis)

The items shown in the right picture are defined as follows.

Hand mass : W_1 (kg)

Distance between the center of J6 axis and the center of gravity of the hand : L_1 (m)

Workpiece mass : W_2 (kg)

Center of gravity of the workpiece : L_2 (m)

Assume that both hand and workpiece are rectangle. When their surface areas can be expressed as follows, respectively: $a_1 \times b_1$, and $a_2 \times b_2$ (where a = height, b = width), the load inertia about the J6 axis is calculated as follows.

$$\begin{aligned} \text{Load inertia about the J6 axis of the hand : } I_1 \text{ (kg}\cdot\text{m}^2) \\ = I_{z1} + W_1 \times L_1^2 = W_1 \times (a_1^2 + b_1^2)/12 + W_1 \times L_1^2 \end{aligned}$$

$$\begin{aligned} \text{Load inertia about the J6 axis of the workpiece : } I_2 \text{ (kg}\cdot\text{m}^2) \\ = I_{z2} + W_2 \times L_2^2 = W_2 \times (a_2^2 + b_2^2)/12 + W_2 \times L_2^2 \end{aligned}$$

$$\text{Total load inertia about the J6 axis of both hand and workpiece : } I \text{ (kg}\cdot\text{m}^2) = I_1 + I_2$$

Check that the value of I is equal to or less than the allowable load moment of the target model.

Note) When the robot changes its posture significantly in a direction other than the vertical downward direction, check the load moment inertia about the J4 axis as well.

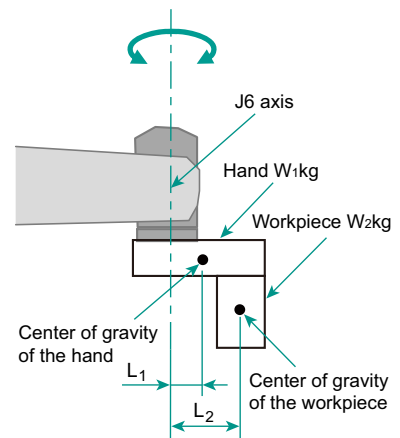

Appendix 2: Classification of external I/O functions

Take note of the following information regarding external I/O functions.

Table 7-1: Classification of external I/O functions

Classification	Function	Description
Safety signals	Emergency stop input	This function detects emergency stop inputs. The STO function will meet Category 4, Performance Level e standards when the safety diagnosis function of the emergency stop input circuit is enabled. This product meets Category 3, Performance Level d at factory settings. To use this product at a performance level of Category 4, Performance Level e, refer to Page 112, "Appendix 3: Safety diagnosis function (test pulse diagnosis)" and set the parameters accordingly.
	Mode selector switch input	This function switches the control mode between manual and automatic.
	Door switch input	This function checks the state of machine guard door switches to detect whether machine guard doors are open.
Non-safety signals	Emergency stop output	This function monitors the emergency stop state of the robot.
	Mode output	This function monitors the manual and automatic operation modes.
	Robot error output	This function monitors the error state of the robot.

Appendix 3: Safety diagnosis function (test pulse diagnosis)

The Safety diagnosis function checks the emergency stop status of the robot using the pulse output from the emergency stop signals (EXTEMG11, EXTEMG21). By changing the settings of TPOEMG, off pulses can be output regularly from EXTEMG11 and EXTEMG21. The width of the pulses that are output is approximately 20 ms. By checking the robot controller test pulses regularly, it is possible to ascertain whether the emergency stop line is working properly.

When using this function, connect emergency stop switches by seeing Fig. 7-2.

Make sure to prevent test pulses of this function from causing faulty operation of peripheral devices.

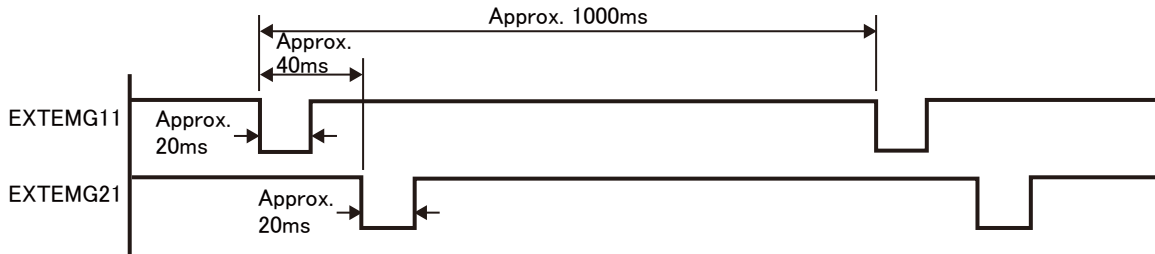

Fig.7-1: Test pulse diagnosis

Table 7-2: Parameter details

Item	Description
Parameter name	TPOEMG
Function	This enables configuring the pulse output function for outputting test pulse signals from emergency stop ports (EXTEMG11, EXTEMG21).
What parameter settings means	0: Outputs no test pulses 1: Outputs test pulses
Default	0

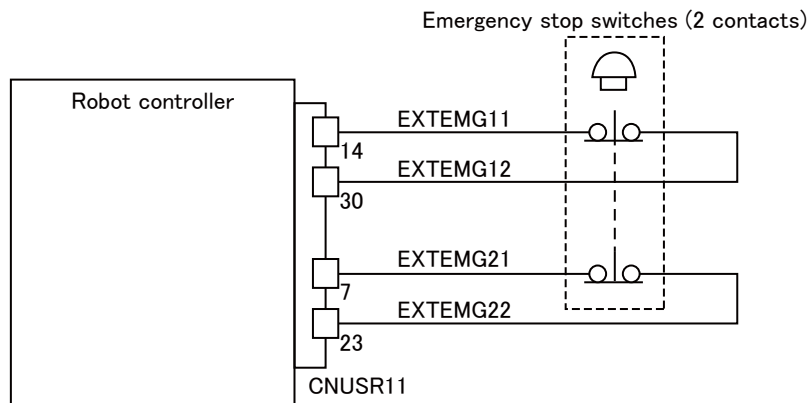

Fig.7-2: How to wire emergency stop lines

Appendix 4: Safety block diagram

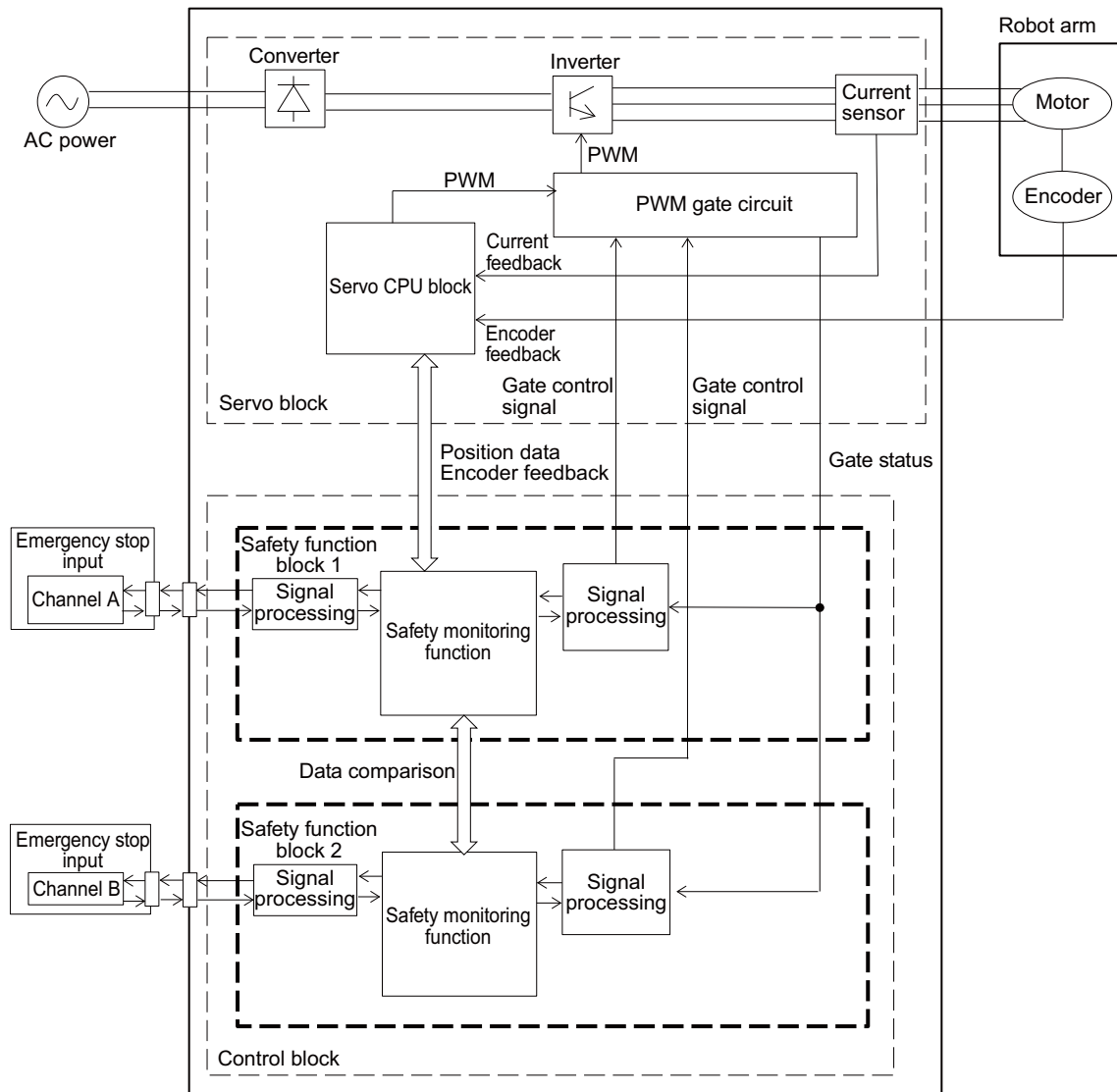

Fig.7-3: Safety block diagram

Appendix 5: Connections of recommended hands, recommended vision sensors and the force sensor

This section explains the connections of recommended hands (all types), recommended vision sensors, and the force sensor.

CAUTION

When using a vision sensor, prevent the J5 and J6 axes from being at the following angles during Joint free mode (direct teaching).

J5 axis: +95° or more

J6 axis: ±20° or more

(1) Hand: Co-act EGP-C40 N-N-Assista (Manufactured by SCHUNK)

Fig. 7-4 shows the connection details of a hand, vision sensor, and force sensor.

The items required depend on which devices are used.

Table 7-3 lists the items required for using each device. Purchase the relevant options. For details on the steps of mounting devices, refer to their Instruction Manuals.

Fig. 7-5 shows the overall view of the robot with a hand and vision sensor mounted.

Fig. 7-6 shows the wiring of a hand and vision sensor to the robot.

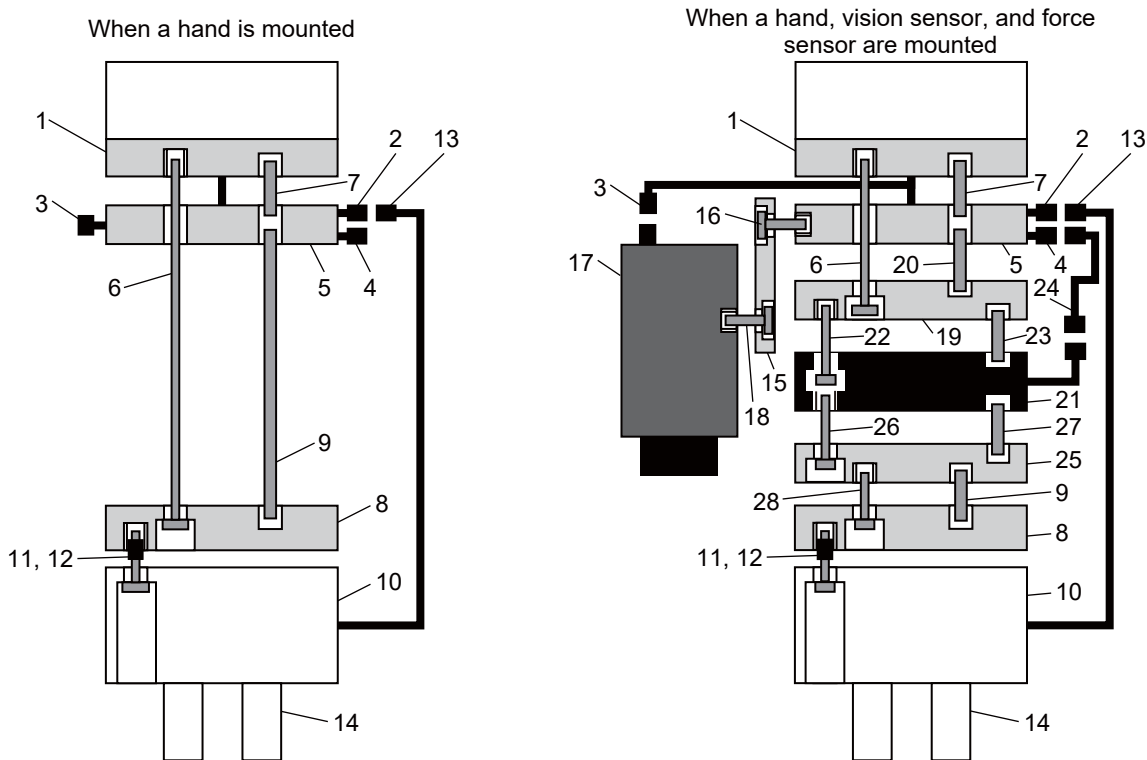

Fig.7-4: Connection details of the hand (Co-act EGP-C40 N-N-Assista)

Table 7-3: List of the items required to use the hand (Co-act EGP-C40 N-N-Assista), vision sensor, and force sensor

No.	Name	Device used (○: Required, -: Not required)				Model
		Hand only	Hand and vision sensor	Hand and force sensor	Hand, vision sensor, and force sensor	
1	Mechanical interface					- (End of the robot arm)
2	Hand connector cable	○	○	○	○	
3	Vision sensor connector cable					
4	Force sensor connector cable					

No.	Name	Device used (○: Required, -: Not required)				Model
		Hand only	Hand and vision sensor	Hand and force sensor	Hand, vision sensor, and force sensor	
5	Hand bracket	○	○	○	○	Co-act EGP-C40 N-N-Assista (Manufactured by SCHUNK)
6	Screw for installing hand brackets					
7	Positioning pin for hand brackets					
8	Adapter plate					
9	Positioning pin for adapter plates					
10	Hand					
11	Screw for mounting hands (inserted into the hand)					
12	Positioning collar for hands (attached to two screws of No.11)					
13	Hand connector cable					
14	Fingers					
15	Vision sensor mounting bracket	-	○	-	○	1F-ASSISTA-2DVSFLG (Manufactured by Mitsubishi Electric)
16	Screw for installing vision sensor mounting brackets (M4 hex socket screw x 2)	-	○	-	○	VS80M-202, VS80M-202-R (Manufactured by Mitsubishi Electric) In-Sight 8402M-363-50, In-Sight 8402M-373-50 (Manufactured by Cognex)
17	Vision sensor	-	○	-	○	
18	Screw for mounting vision sensors (M3 hex socket screw x 4)	-	○	-	○	4F-FS002H-W200 (Manufactured by Mitsubishi Electric)
19	Vision sensor mounting adapter	-	-	○	○	
20	Positioning pin for sensor mounting adapters (φ5 pin x 1)					
21	Force sensor					
22	Screw for mounting force sensors (inserted into the force sensor, M6 hex socket screw x 4)					
23	Positioning pin for force sensors (φ3 pin x 2)					
24	Force sensor conversion cable	-	-	○	○	1F-ASSISTA-ADCBL (Manufactured by Mitsubishi Electric)

No.	Name	Device used (○: Required, -: Not required)				Model
		Hand only	Hand and vision sensor	Hand and force sensor	Hand, vision sensor, and force sensor	
25	Flange for connecting force sensors to adapter plates	-	-	○	○	- (Fabrication required) ^{Note1)}
26	Screw for mounting flanges to connect force sensors to adapter plates					
27	Positioning pin for flanges to connect force sensors to adapter plates					
28	Screw for mounting flanges to connect force sensors to adapter plates					

Note1) For information on hands, refer to [Page 10, "1.4.5 Recommended hands"](#) and contact the manufacturer.

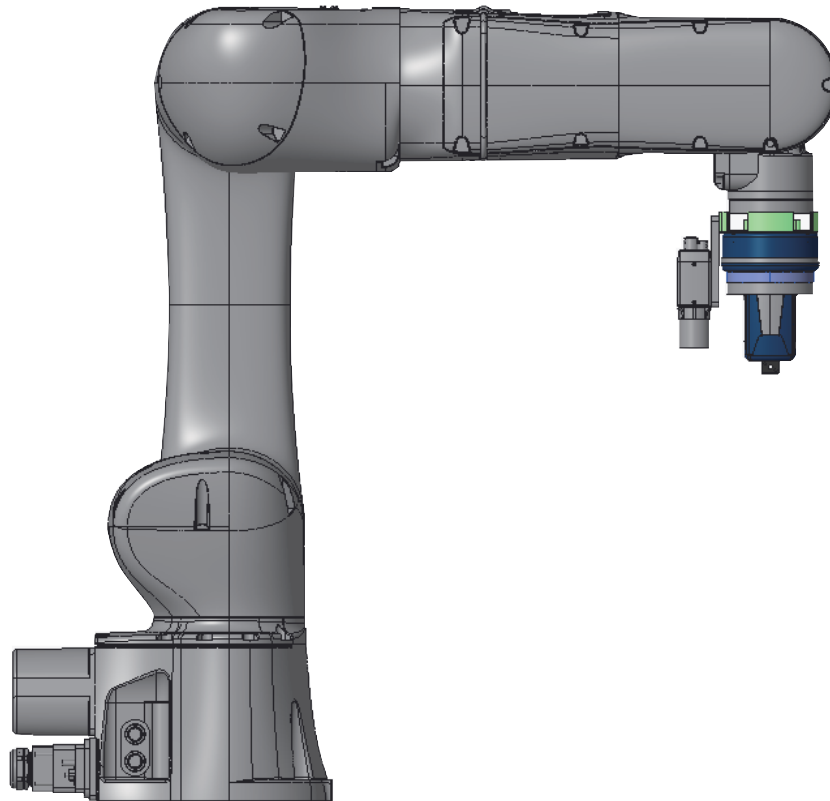

Fig.7-5: Overall view of the robot with the hand (Co-act EGP-C40 N-N-Assista) and a vision sensor mounted

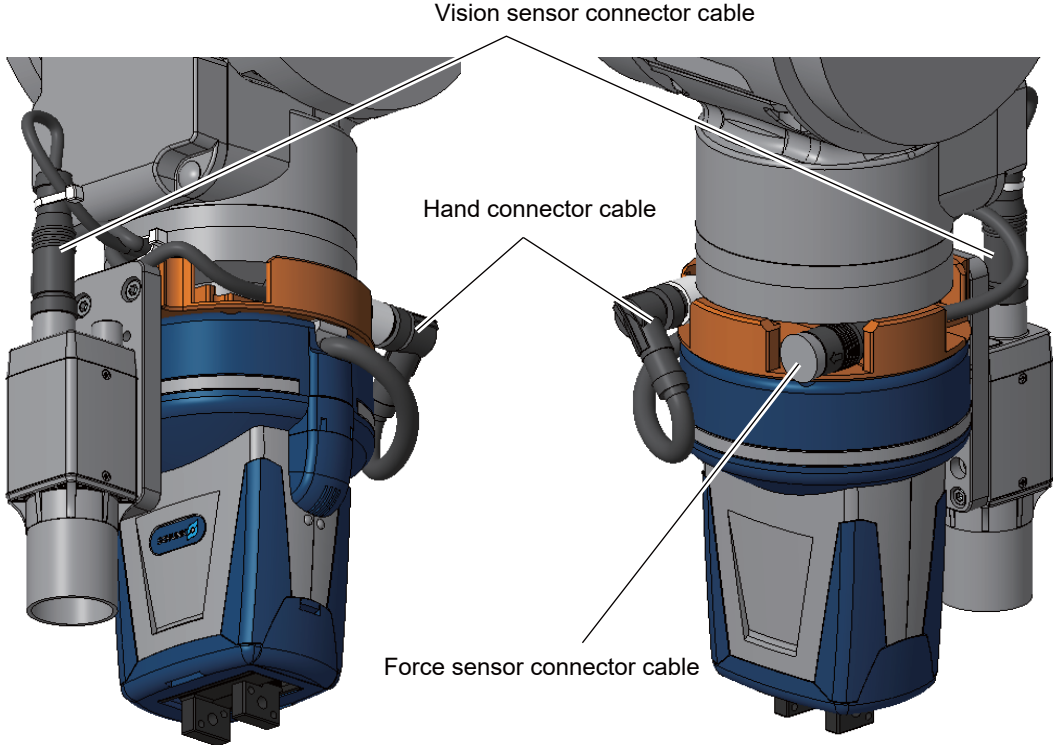
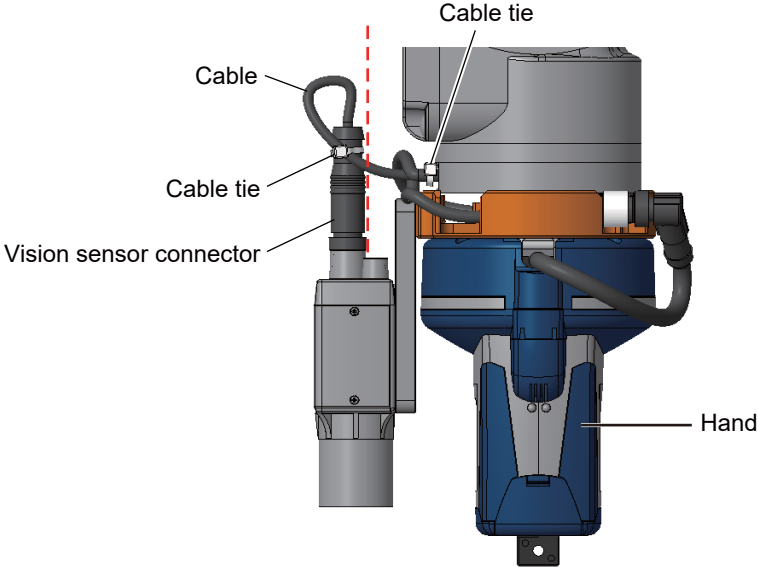

Fig.7-6: Wiring of the hand (Co-act EGP-C40 N-N-Assista) and a vision sensor to the robot

CAUTION

Check that the cable fixed with a cable tie does not cross the dotted line as shown in the figure below.



⚠ CAUTION

To prevent interference due to cable sag, check that the hand connector has been installed at the angle shown below before attaching the hand.

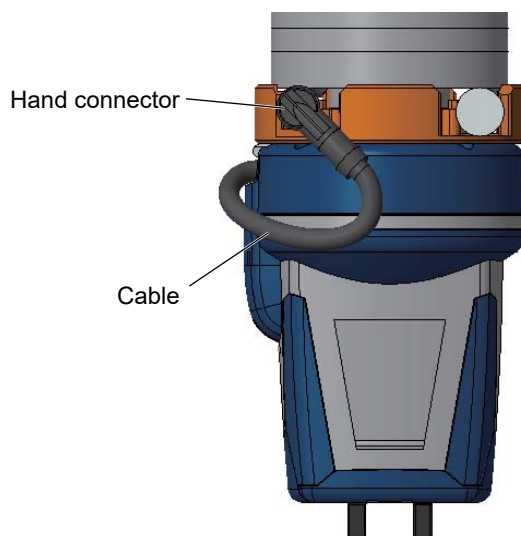

(2) Hand: HRC-03-099455 (Manufactured by Zimmer Group)

Fig. 7-7 shows the connection details of a hand, vision sensor, and force sensor.

The items required depend on which devices are used.

Table 7-4 lists the items required for using each device. Purchase the relevant options. For details on the steps of mounting devices, refer to their Instruction Manuals.

Fig. 7-8 shows the overall view of the robot with a hand and vision sensor mounted.

Fig. 7-9 shows the wiring of a hand and vision sensor to the robot.

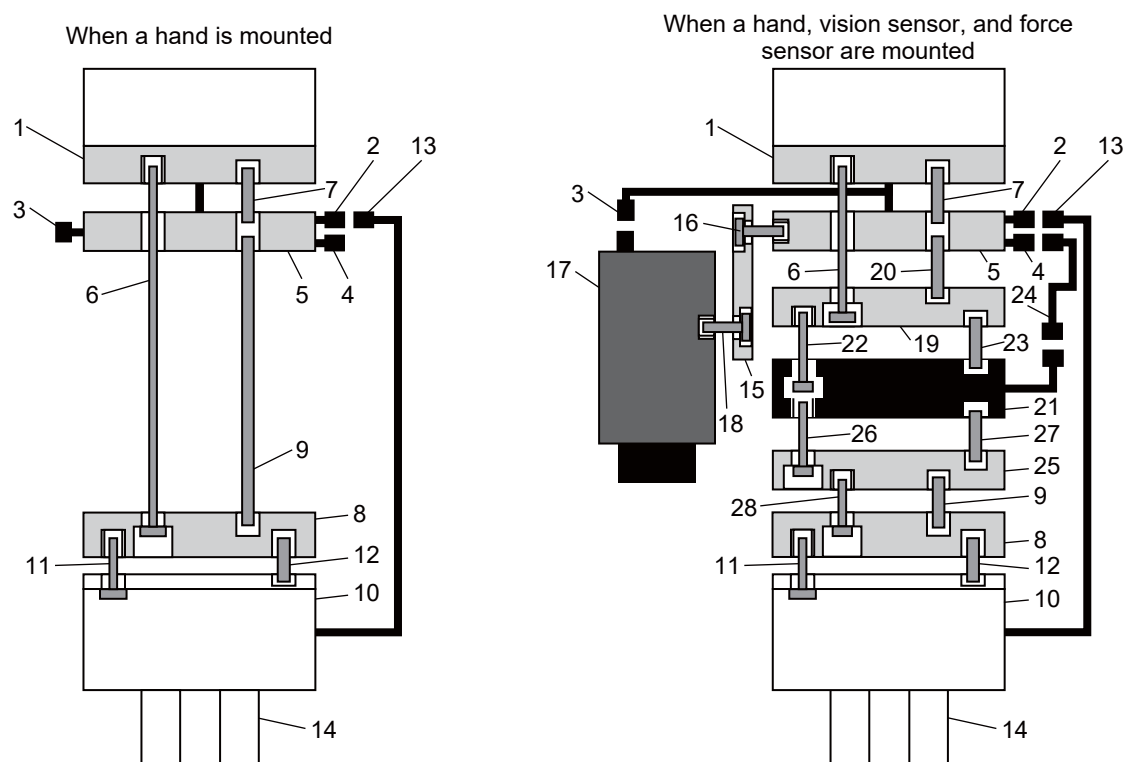

Fig.7-7: Connection details of the hand (HRC-03-099455)

Table 7-4: List of the items required to use the hand (HRC-03-099455), vision sensor, and force sensor

No.	Name	Device used (○: Required, -: Not required)				Model
		Hand only	Hand and vision sensor	Hand and force sensor	Hand, vision sensor, and force sensor	
1	Mechanical interface					- (End of the robot arm)
2	Hand connector cable	○	○	○	○	
3	Vision sensor connector cable					
4	Force sensor connector cable					

7 Appendix

No.	Name	Device used (○: Required, -: Not required)				Model
		Hand only	Hand and vision sensor	Hand and force sensor	Hand, vision sensor, and force sensor	
5	Hand bracket	○	○	○	○	HRC-03-099455 (Manufactured by Zimmer Group)
6	Screw for installing hand brackets					
7	Positioning pin for hand brackets					
8	Adapter plate					
9	Positioning pin for adapter plates					
10	Hand					
11	Screw for mounting hands					
12	Positioning pin for hands					
13	Hand connector cable					
14	Fingers	-	○	-	○	1F-ASSISTA-2DVSFLG (Manufactured by Mitsubishi Electric)
15	Vision sensor mounting bracket					
16	Screw for installing vision sensor mounting brackets (M4 hex socket screw x 2)					
17	Vision sensor					
18	Screw for mounting vision sensors (M3 hex socket screw x 4)					
19	Vision sensor mounting adapter					
20	Positioning pin for sensor mounting adapters (φ5 pin x 1)					
21	Force sensor					
22	Screw for mounting force sensors (inserted into the force sensor, M6 hex socket screw x 4)					
23	Positioning pin for force sensors (φ3 pin x 2)	-	-	○	○	4F-FS002H-W200 (Manufactured by Mitsubishi Electric)
24	Force sensor conversion cable					

No.	Name	Device used (○: Required, -: Not required)				Model
		Hand only	Hand and vision sensor	Hand and force sensor	Hand, vision sensor, and force sensor	
25	Flange for connecting force sensors to adapter plates	-	-	○	○	- (Fabrication required) ^{Note1)}
26	Screw for mounting flanges to connect force sensors to adapter plates					
27	Positioning pin for flanges to connect force sensors to adapter plates					
28	Screw for mounting flanges to connect force sensors to adapter plates					

Note1) For information on hands, refer to [Page 10, "1.4.5 Recommended hands"](#) and contact the manufacturer.

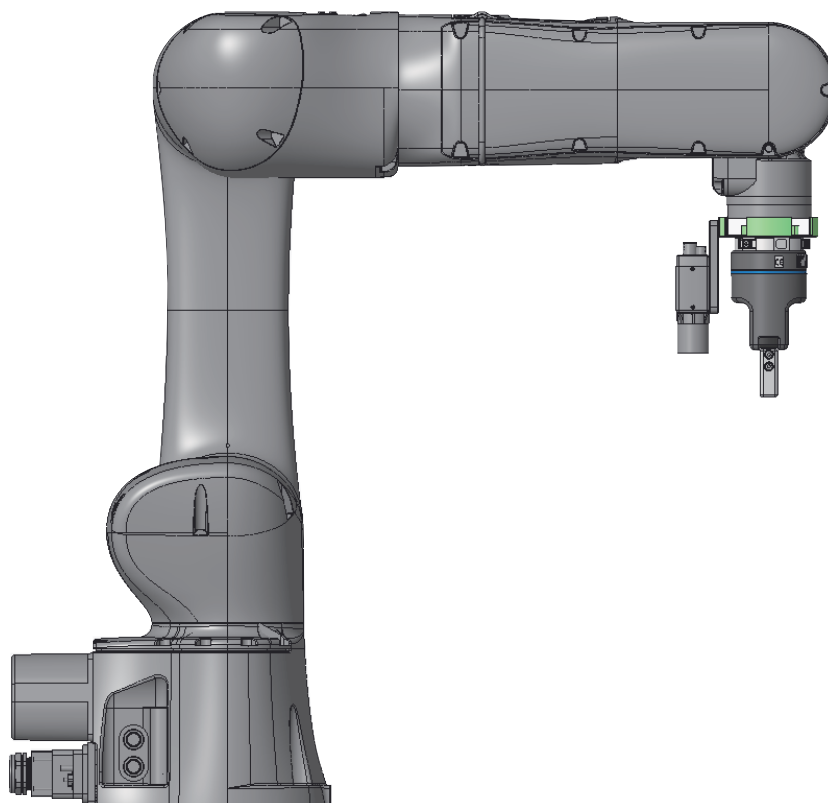

Fig.7-8: Overall view of the robot with the hand (HRC-03-099455) and a vision sensor mounted

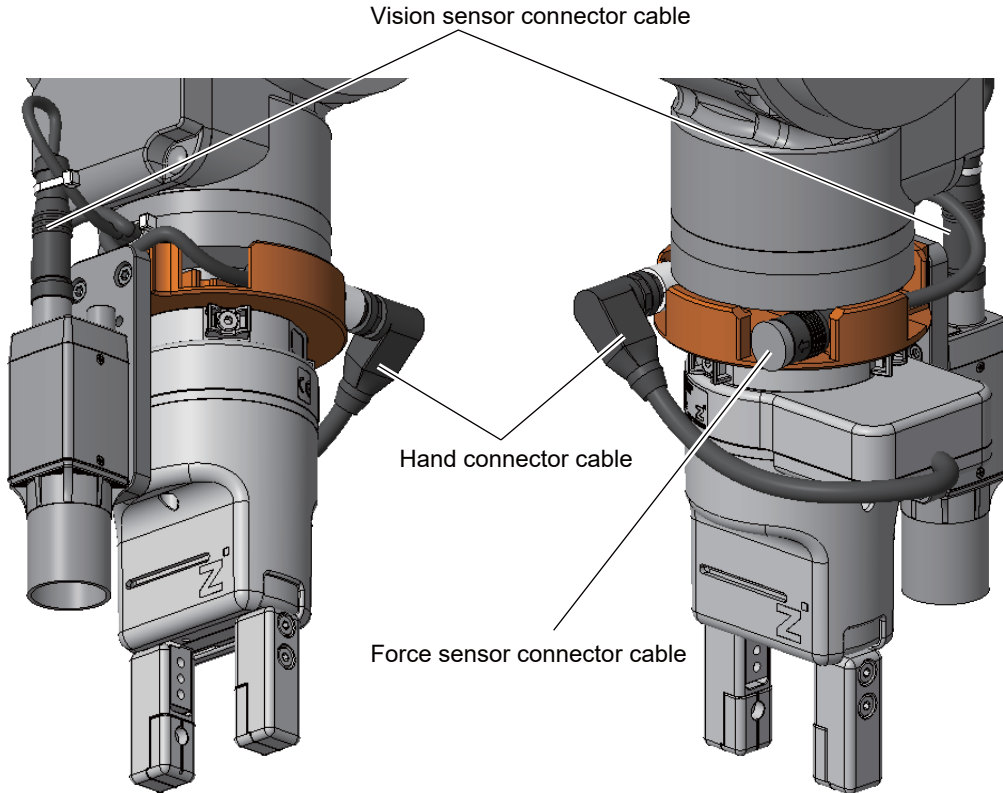
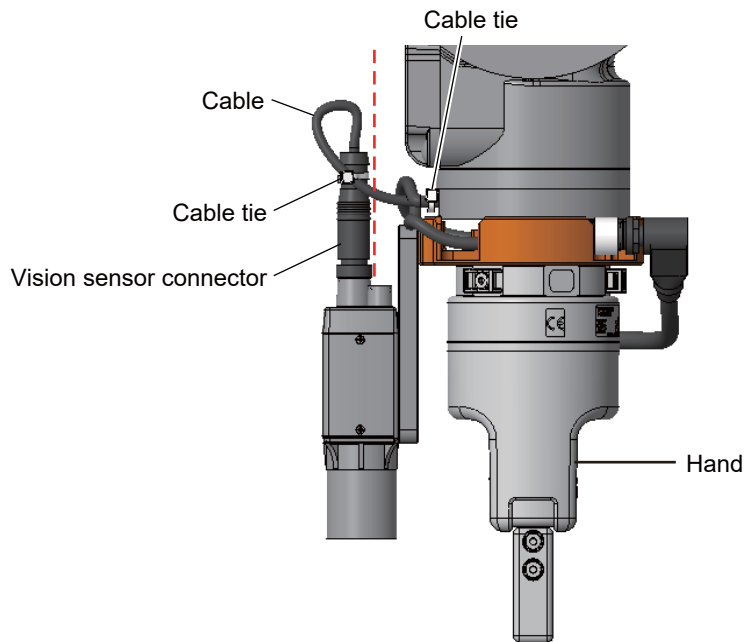

Fig.7-9: Wiring of the hand (HRC-03-099455) and a vision sensor to the robot

⚠ CAUTION

Check that the cable fixed with a cable tie does not cross the dotted line as shown in the figure below.



(3) Hand: KIT-ASSISTA-G (Manufactured by GIMATIC)

Fig. 7-10 shows the connection details of a hand, vision sensor, and force sensor.

The items required depend on which devices are used.

Table 7-5 lists the items required for using each device. Purchase the relevant options. For details on the steps of mounting devices, refer to their Instruction Manuals.

Fig. 7-11 shows the overall view of the robot with a hand and vision sensor mounted.

Fig. 7-12 shows the wiring of a hand and vision sensor to the robot.

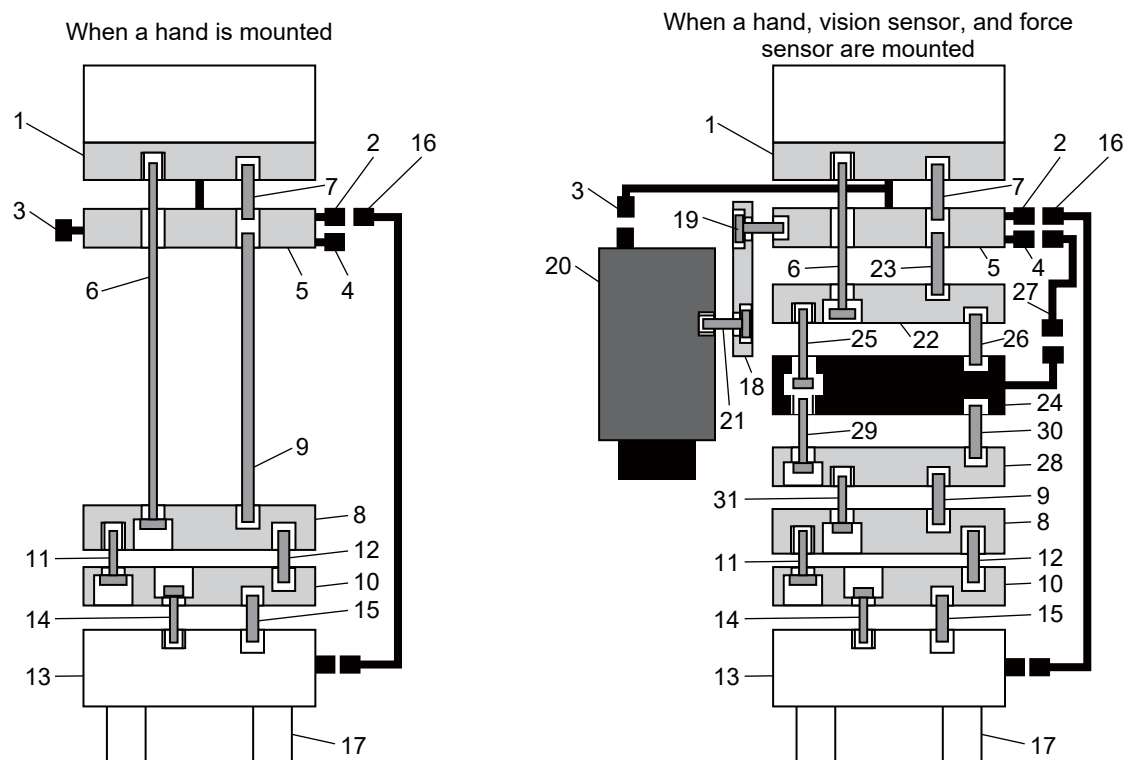

Fig.7-10: Connection details of the hand (KIT-ASSISTA-G)

Table 7-5: List of the items required to use the hand (KIT-ASSISTA-G), vision sensor, and force sensor

No.	Name	Device used (○: Required, -: Not required)				Model
		Hand only	Hand and vision sensor	Hand and force sensor	Hand, vision sensor, and force sensor	
1	Mechanical interface					- (End of the robot arm)
2	Hand connector cable	○	○	○	○	
3	Vision sensor connector cable					
4	Force sensor connector cable					

7 Appendix

No.	Name	Device used (○: Required, -: Not required)				Model
		Hand only	Hand and vision sensor	Hand and force sensor	Hand, vision sensor, and force sensor	
5	Hand bracket	○	○	○	○	KIT-ASSISTA-G (Manufactured by GIMATIC)
6	Screw for installing hand brackets					
7	Positioning pin for hand brackets					
8	Adapter plate 1					
9	Positioning pin for adapter plate 1					
10	Adapter plate 2					
11	Screw for mounting adapter plate 2					
12	Positioning pin for adapter plate 2					
13	Hand					
14	Screw for mounting hands					
15	Positioning pin for hands					
16	Hand connector cable					
17	Fingers	○	○	○	○	-(Fabrication required) ^{Note1)}
18	Vision sensor mounting bracket	-	○	-	○	1F-ASSISTA-2DVSFLG (Manufactured by Mitsubishi Electric)
19	Screw for installing vision sensor mounting brackets (M4 hex socket screw x 2)					
20	Vision sensor	-	○	-	○	VS80M-202, VS80M-202-R (Manufactured by Mitsubishi Electric) In-Sight 8402M-363-50, In-Sight 8402M-373-50 (Manufactured by Cognex)
21	Screw for mounting vision sensors (M3 hex socket screw x 4)					
22	Vision sensor mounting adapter	-	-	○	○	4F-FS002H-W200 (Manufactured by Mitsubishi Electric)
23	Positioning pin for sensor mounting adapters (φ5 pin x 1)					
24	Force sensor					
25	Screw for mounting force sensors (inserted into the force sensor, M6 hex socket screw x 4)					
26	Positioning pin for force sensors (φ3 pin x 2)					
27	Force sensor conversion cable	-	-	○	○	1F-ASSISTA-ADCBL (Manufactured by Mitsubishi Electric)

No.	Name	Device used (○: Required, -: Not required)				Model
		Hand only	Hand and vision sensor	Hand and force sensor	Hand, vision sensor, and force sensor	
28	Flange for connecting force sensors to adapter plates	-	-	○	○	- (Fabrication required) ^{Note2)}
29	Screw for mounting flanges to connect force sensors to adapter plates					
30	Positioning pin for flanges to connect force sensors to adapter plates					
31	Screw for mounting flanges to connect force sensors to adapter plates					

Note1) Refer to "Fig. 7-13: Opening and closing of the hand" and position fingers correctly.

Note2) For information on hands, refer to Page 10, "1.4.5 Recommended hands" and contact the manufacturer.

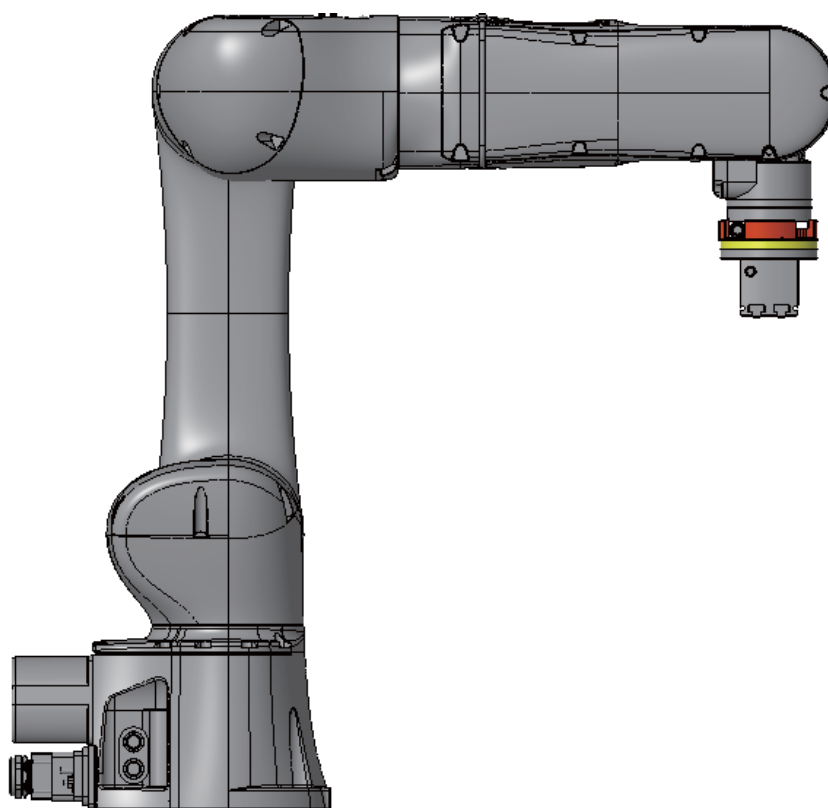

Fig.7-11: Overall view of the robot with the hand (KIT-ASSISTA-G) and a vision sensor mounted

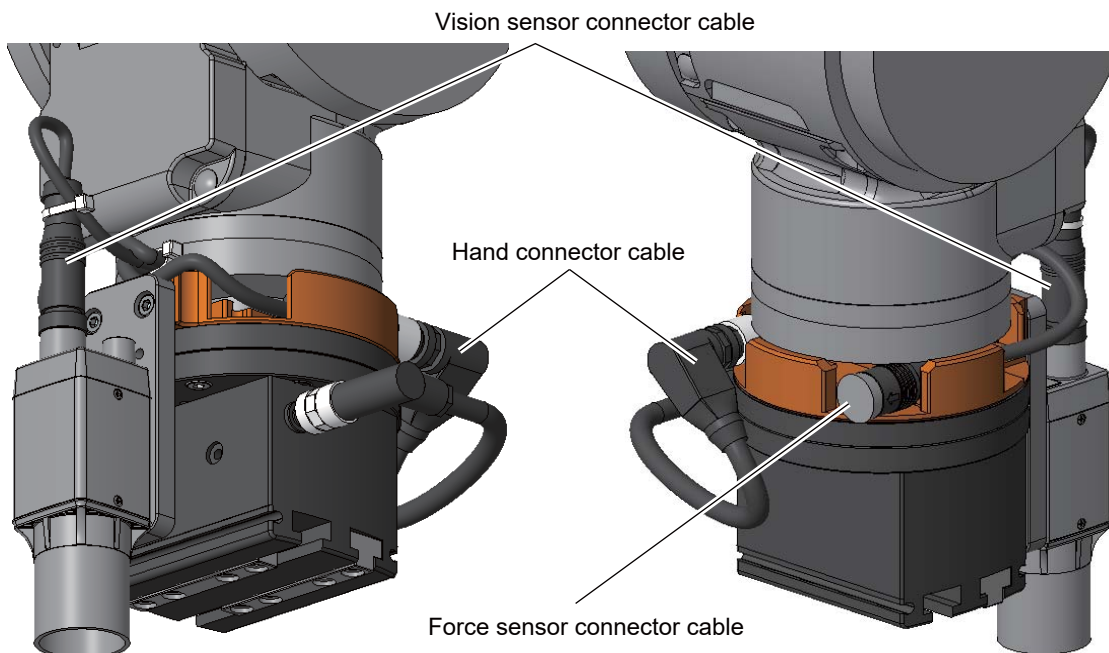
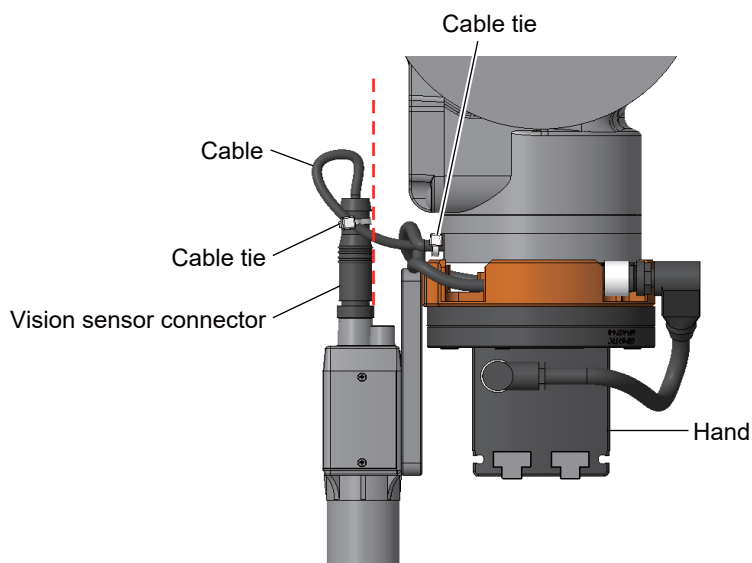

Fig.7-12: Wiring of the hand (KIT-ASSISTA-G) and a vision sensor to the robot

⚠ CAUTION

Check that the cable fixed with a cable tie does not cross the dotted line as shown in the figure below.



⚠ CAUTION

To prevent interference due to cable sag, check that the hand connector has been installed at the angle shown below before attaching the hand.

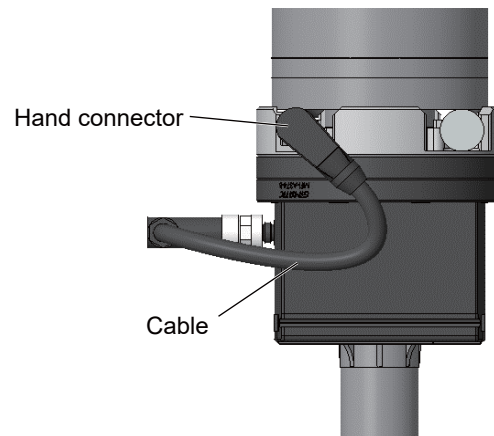
**⚠ CAUTION**

Fingers must be created and attached to the hand (KIT-ASSISTA-G). Refer to the following figure "Opening and closing of the hand" and position fingers correctly.

In the initial settings, the electric hand opens upon power on. Keep in mind that workpieces may drop in certain conditions.

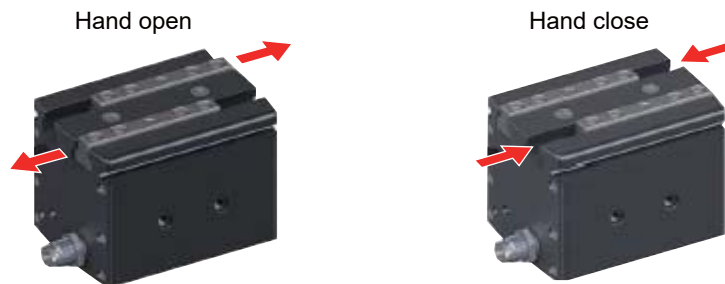

Fig.7-13: Opening and closing of the hand (KIT-ASSISTA-G)

(4) Hand: ROB-SET ECBPM ASSISTA (Manufactured by SCHMALZ)

Fig. 7-14 shows the connection details of a hand, vision sensor, and force sensor.

The items required depend on which devices are used.

Table 7-6 lists the items required for using each device. Purchase the relevant options. For details on the steps of mounting devices, refer to their Instruction Manuals.

Fig. 7-15 shows the overall view of the robot with a hand and vision sensor mounted.

Fig. 7-16 shows the wiring of a hand and vision sensor to the robot.

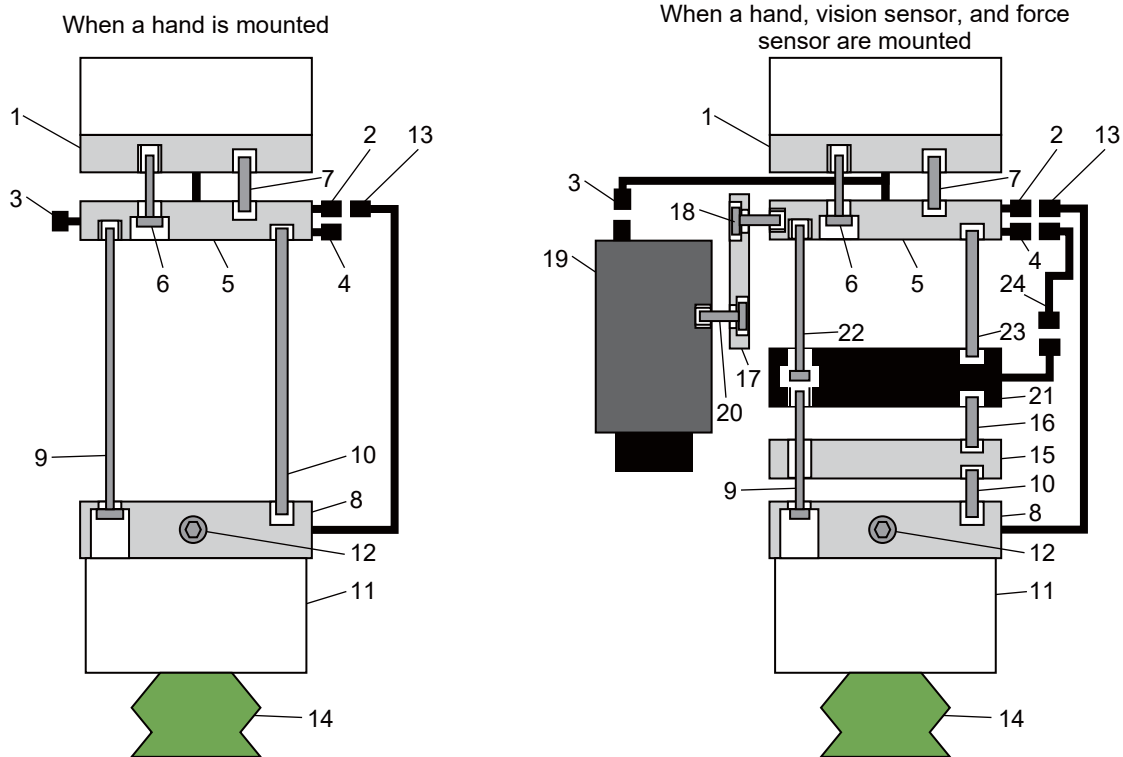

Fig.7-14: Connection details of the hand (ROB-SET ECBPM ASSISTA)

Table 7-6: List of the items required to use the hand (ROB-SET ECBPM ASSISTA), vision sensor, and force sensor

No.	Name	Device used (○: Required, -: Not required)				Model
		Hand only	Hand and vision sensor	Hand and force sensor	Hand, vision sensor, and force sensor	
1	Mechanical interface					- (End of the robot arm)
2	Hand connector cable	○	○	○	○	
3	Vision sensor connector cable					
4	Force sensor connector cable					

No.	Name	Device used (○: Required, -: Not required)				Model
		Hand only	Hand and vision sensor	Hand and force sensor	Hand, vision sensor, and force sensor	
5	Hand bracket	○	○	○	○	ROB-SET ECBPM ASSISTA (Manufactured by SCHMALZ)
6	Screw for installing hand brackets					
7	Positioning pin for hand brackets					
8	Flange with cable					
9	Screw for attaching the flange with cable					
10	Positioning pin for the flange with cable					
11	Hand					
12	Screw for mounting hands					
13	Hand connector cable					
14	Suction pad					
15	Distance plate	-	-	○	○	- (Fabrication required) ^{Note1)}
16	Positioning pin for distance plates	-	-	○	○	
17	Vision sensor mounting bracket	-	○	-	○	1F-ASSISTA-2DVSFLG (Manufactured by Mitsubishi Electric)
18	Screw for installing vision sensor mounting brackets (M4 hex socket screw x 2)	-	○	-	○	
19	Vision sensor	-	○	-	○	VS80M-202, VS80M-202-R (Manufactured by Mitsubishi Electric) In-Sight 8402M-363-50, In-Sight 8402M-373-50 (Manufactured by Cognex)
20	Screw for mounting vision sensors (M3 hex socket screw x 4)	-	○	-	○	
21	Force sensor	-	-	○	○	4F-FS002H-W200 (Manufactured by Mitsubishi Electric)
22	Screw for mounting force sensors ((inserted into the force sensor, M6 hex socket screw x 4))	-	-	○	○	
23	Positioning pin for force sensors (φ3 pin x 2)	-	-	○	○	
24	Force sensor conversion cable	-	-	○	○	1F-ASSISTA-ADCBL (Manufactured by Mitsubishi Electric)

Note1) Select the screw No. 9 suitable for the distance plate.

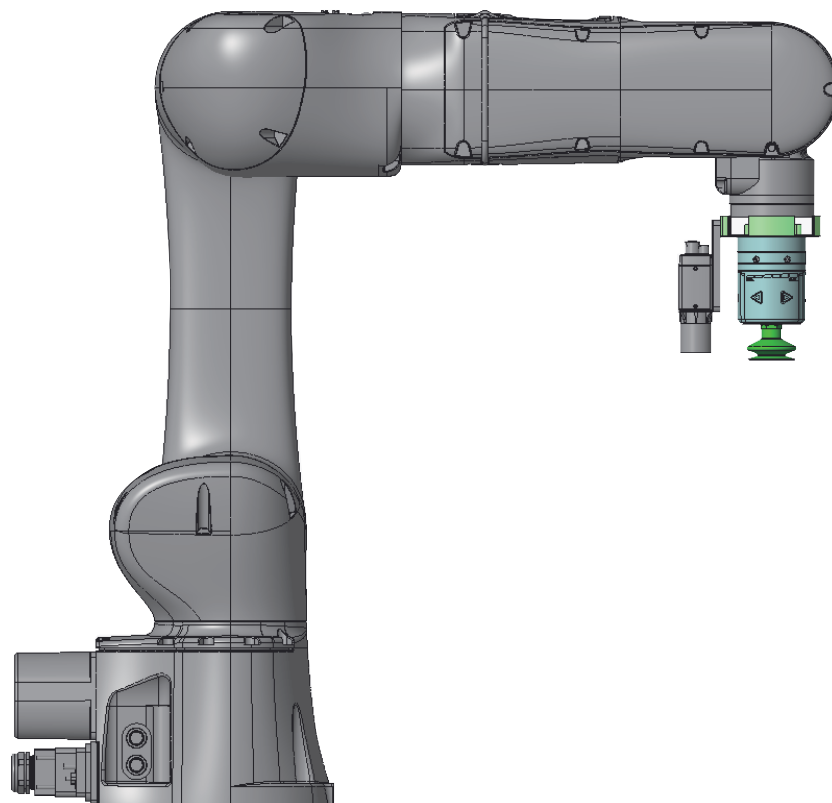

Fig.7-15: Overall view of the robot with the hand (ROB-SET ECBPM ASSISTA) and a vision sensor mounted

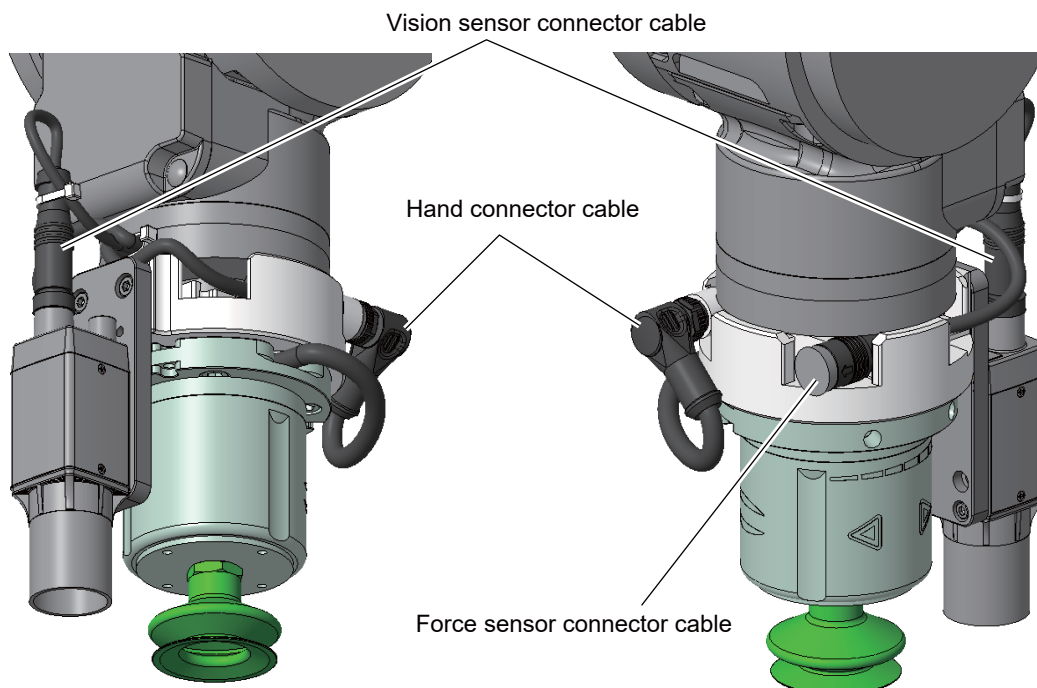
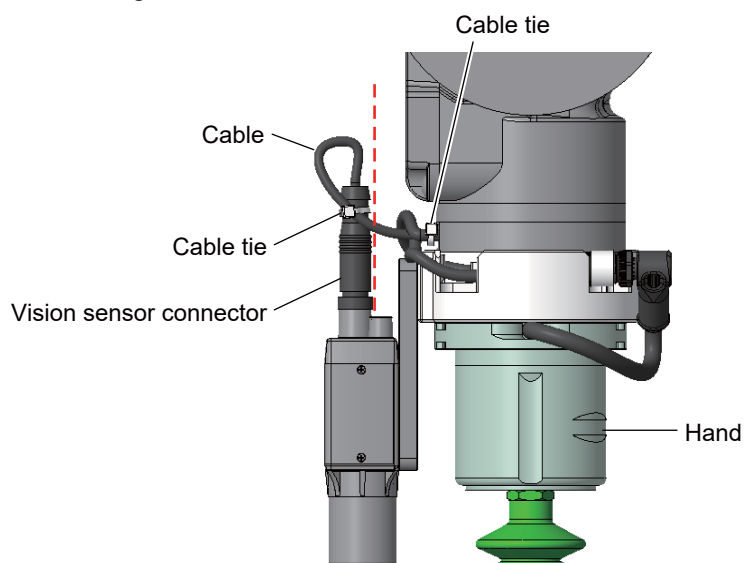

Fig.7-16: Wiring of the hand (ROB-SET ECBPM ASSISTA) and a vision sensor to the robot

⚠ CAUTION

Check that the cable fixed with a cable tie does not cross the dotted line as shown in the figure below.

**⚠ CAUTION**

To prevent interference due to cable sag, check that the hand connector has been installed at the angle shown below before attaching the hand.

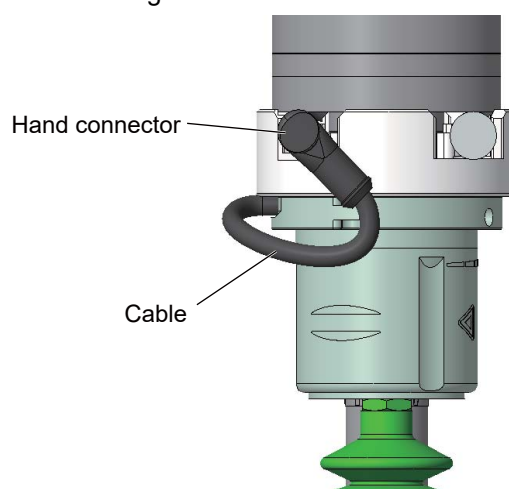

Appendix 6: Declaration of Conformity

The latest version of the Declaration of Conformity (hardcopy) is included with the product.



EU DECLARATION OF CONFORMITY (EMC Directive, RoHS Directive)
 EU DECLARATION OF INCORPORATION OF PARTLY COMPLETE MACHINERY
 (Machinery Directive)

We,
 Manufacturer : MITSUBISHI ELECTRIC CORPORATION
 Address : TOKYO 100-8310, JAPAN
 (Place of Declare)
 Brand Name : 

declare under our sole responsibility that the product
 Description : Industrial robot
 Type of Model : AS (See appendix)
 Notice : Refer to Appendix for each type name
 For industrial environment only

to which this declaration relates is in conformity with the following standard and directive.

Directive		Harmonized Standard	Notified Body
EMC Directive	2014/30/EU	EN 61000-6-4:2007/A1:2011 EN 61000-6-2:2005 EN 61800-3:2004/A1:2012 (Category C2, Second Environment)	1
Machinery Directive	2006/42/EC	EN ISO 12100:2010 EN ISO 10218-1:2011 EN ISO 13849-1:2015 ISO/TS 15066:2016 EN 60204-1:2006/A1:2009 EN ISO 4414:2010 EN ISO 13850:2015 EN 349:1993/A1:2008	—
RoHS Directive	2011/65/EU	EN 50581:2012 EN 62321:2009	—

This declaration is based on the conformity assessment of following Notified Body		
No.	Name and Address	Identification Number
1	TÜV SÜD Product Service GmbH, Ridlerstrasse 65 80339 Muenchen	0123

Essential requirements of Machinery Directive are applied and fulfilled and the relevant technical documentation is compiled in accordance with part B of Annex VII of Machinery Directive.
 The product above complies with all applicable health and safety requirements of the Machinery Directive, annex I, sections 1.1.3, 1.1.5, 1.2.1, 1.2.3, 1.2.5, 1.2.6, 1.3.2, 1.3.3, 1.3.4, 1.3.8.1, 1.3.9, 1.5.1, 1.5.2, 1.5.4-1.5.10, 1.5.16, 1.6.1, 1.6.2, 1.6.3, 1.6.4, 1.7.1.1, 1.7.3, 1.7.4 .
 If National authorities require relevant information on this product by rational reasons, we transmit its information by mail.

This product must not be put into service until the final machinery into which it is to be incorporated has been declared in conformity with Machinery Directive.

Authorized representative in Europe
 MITSUBISHI ELECTRIC EUROPE B.V., German Branch
 Mitsubishi-Electric-Platz 1, 40882 Ratingen, Germany

Issue Date (Date of Declaration): 13 Apr. 2020

Signed for and on behalf of

(Signature) Tomu Otsuka
 [Toru Otsuka]
 General Manager, Robot Manufacturing Department
 MITSUBISHI ELECTRIC CORPORATION

Appendix
List 1 Type name to declare

Robot type	Robot model
RV-5AS-D	RV-5AS-D

Appendix 7: Specifications discussion material

■ Customer information

Company name		Name	
Address		Telephone	

■ Purchased model

Type ^{Note1)}	Controller
RV-5AS-D	CR800-05VD

Note1) Refer to the [Page 2, "1.2 Model type name of robot"](#) for the details of the robot arm type name.

■ Options (Installable after shipment)

Item		Type	Provision, and specifications when provided.
Robot arm	Machine cable (replacement)	1F-□UCBL-41	Fixed type: <input type="checkbox"/> Not provided <input type="checkbox"/> 2m <input type="checkbox"/> 10m
	Solenoid valve set	1F-VD0□-01 1F-VD0□E-01	<input type="checkbox"/> Not provided 1F-VD0□-01 (Sink): <input type="checkbox"/> 1 valve <input type="checkbox"/> 2 valves 1F-VD0□E-01 (Source): <input type="checkbox"/> 1 valve <input type="checkbox"/> 2 valves
	2-piece force sensor conversion cable set	1F-ASSISTA-ADCBL	<input type="checkbox"/> Not provided <input type="checkbox"/> Provided
	Vision sensor mounting bracket	1F-ASSISTA-2DVSFLG	<input type="checkbox"/> Not provided <input type="checkbox"/> Provided
Control-ler	Simple teaching pendant	R32TB-□□	<input type="checkbox"/> Not provided <input type="checkbox"/> 7m <input type="checkbox"/> 15m
	Highly efficient teaching pendant	R56TB-□□	<input type="checkbox"/> Not provided <input type="checkbox"/> 7m <input type="checkbox"/> 15m
	Parallel I/O interface	2D-TZ368/ 2D-TZ378	<input type="checkbox"/> Not provided 2D-TZ368(Sink type)/ <input type="checkbox"/> -1pc. <input type="checkbox"/> -2pc. 2D-TZ378(Source type)/ <input type="checkbox"/> -1pc. <input type="checkbox"/> -2pc.
	External I/O cable (For parallel I/O interface)	2D-CBL□□ (2D-TZ368/TZ378)	<input type="checkbox"/> Not provided <input type="checkbox"/> 5m-()pc. <input type="checkbox"/> 15m-()pc.
	CC-Link interface	2D-TZ576	<input type="checkbox"/> Not provided <input type="checkbox"/> Provided
	EtherNet/IP interface	2D-TZ535	<input type="checkbox"/> Not provided <input type="checkbox"/> Provided
	PROFINET interface	2D-TZ535-PN	<input type="checkbox"/> Not provided <input type="checkbox"/> Provided
	CC-Link IE Field interface	2F-DQ535	<input type="checkbox"/> Not provided <input type="checkbox"/> Provided
	EtherCAT interface	2F-DQ535-EC	<input type="checkbox"/> Not provided <input type="checkbox"/> Provided
	SD memory card	2F-2GBSD	<input type="checkbox"/> Not provided <input type="checkbox"/> Provided
	RT ToolBox3	3F-14C-WINE	<input type="checkbox"/> Not provided <input type="checkbox"/> Windows7/8.1/10 English DVD-ROM
	RT ToolBox3 mini	3F-15C-WINE	<input type="checkbox"/> Not provided <input type="checkbox"/> Windows 7/8.1/10 English DVD-ROM
	RT VisualBox	3G-30C-WINE	<input type="checkbox"/> Not provided <input type="checkbox"/> Windows 10 English CD-ROM
Function extension	Force sensor set	4F-FS002H-W200	<input type="checkbox"/> Not provided <input type="checkbox"/> Provided
	MELFA-3D Vision 3.0	3F-53U-WINM	<input type="checkbox"/> Not provided <input type="checkbox"/> Provided

■ Maintenance parts (Consumable parts)

Maintenance parts	<input type="checkbox"/> Backup batteries ER6V () pcs.
-------------------	---

■ Robot selection check list

Work description	<input type="checkbox"/> Material handling <input type="checkbox"/> Assembly <input type="checkbox"/> Machining L/UL <input type="checkbox"/> Sealing <input type="checkbox"/> Testing and inspection <input type="checkbox"/> Other ()		
Workpiece mass ()g	Hand mass ()g	Atmosphere <input type="checkbox"/> General environment <input type="checkbox"/> Oil mist: Confirm oil proof <input type="checkbox"/> request (Oil name:) ^{Note1)} / <input type="checkbox"/> not request <input type="checkbox"/> Other ()	
Remarks			

Note1) Refer to [Page 17, "2.2.6 Protection specifications"](#) about oil resistance.

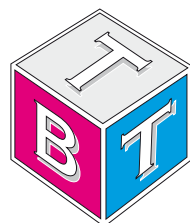

Technisches **B**üro **T**raffa

Zentrale:
TBT Technisches Büro Traffa e.K.
Theodor-Heuss-Str. 8
71336 Waiblingen
Tel.: +49 (0)7151/60424-0
Fax.: +49 (0)7151/60424-40
info@traffa.de
www.traffa.de

NL Bayern:
TBT Technisches Büro Traffa e.K.
Schöneckerstr. 4
91522 Ansbach
Tel.: +49 (0)981/487866-50
Fax.: +49 (0)981/487866-55
mail@traffa.de
www.traffa.de