

Installation and Maintenance Manual

Electric Actuator / Guide Rod Type

Series LEYG



Applicable model number:
(*-)LEYG*G*(S/T/V)*-*



Note: For special models LEYG*-X* please check the appropriate drawing for the dimensions and specifications.

1 Safety Instructions

This manual contains essential information for the protection of users and others from possible injury and/or equipment damage.

- Read this manual before using the product to ensure correct handling and also read the manuals of related apparatus before use.
- Keep this manual in a safe place for future reference.
- These instructions indicate the level of potential hazard by label of "Caution", "Warning" or "Danger", followed by important safety information which must be carefully followed.
- To ensure safety of personnel and equipment the safety instructions in this manual and the product catalogue must be observed, along with other relevant safety practices.

Caution	Indicates a hazard with a low level of risk which, if not avoided, could result in minor or moderate injury.
Warning	Indicates a hazard with a medium level of risk, which, if not avoided, could result in death or serious injury.
Danger	Indicates a hazard with a high level of risk which, if not avoided, will result in death or serious injury.

- Electromagnetic compatibility: This product is class A equipment that is intended for use in an industrial environment. There may be potential difficulties in ensuring electromagnetic compatibility in other environments due to conducted as well as radiated disturbances.

Warning

- **Do not disassemble, modify (including change of printed circuit board) or repair the product.**
An injury or product failure may result.
- **Do not operate the product beyond the specification range.**
Fire, malfunction or equipment damage may result.
Use the product only after confirming the specifications.
- **Do not use the product in the presence of flammable, explosive or corrosive gas.**
Fire, explosion or corrosion may result.
This product does not have an explosion proof construction.
- **When using the product as part of an interlocking system:**
Provide a double interlocking system, for example a mechanical system.
Check the product regularly to ensure correct operation.
- **Before performing maintenance, be sure of the following:**
Turn off the power supply.

Caution

- **Always perform a system check after maintenance.**
Do not use the product if any error occurs.
Safety cannot be assured if caused by un-intentional malfunction.
- **Provide grounding to ensure correct operation and to improve noise resistance of the product.**
This product should be individually grounded using a short cable.
- **Follow the instructions given below when handling the product.**
Failing to do so may result in product damage.
- **Maintenance space should always be provided around the product.**
- **Do not remove labels from the product.**
- **Do not drop, hit or apply excessive shock to the product.**
- **Unless stated otherwise, follow all specified tightening torques.**
- **Do not bend, apply tensile force, or apply force by placing heavy loads on the cables.**

1 Safety Instructions (continued)

- **Connect wires and cables correctly and do not connect while the power is turned on.**
- **Do not route input/output wires and cables together with power or high-voltage cables.**
- **Check the insulation of wires and cables.**
- **Take appropriate measures against noise, such as noise filters, when the product is incorporated into other equipment or devices.**
- **Take sufficient shielding measures when the product is to be used in the following conditions:**
 - Where noise due to static electricity is generated.
 - Where electro-magnetic field strength is high.
 - Where radioactivity is present.
 - Where power lines are located.
- **Do not use the product in a place where electrical surges are generated.**
- **Use suitable surge protection when a surge generating load such as a solenoid valve is to be directly driven.**
- **Prevent any foreign matter from entering this product.**
- **Do not expose the product to vibration or impact.**
- **Use the product within the specified ambient temperature range.**
- **Do not expose the product to any heat radiation.**
- **Use a precision screwdriver with flat blade to adjust the DIP switch.**
- **Close the cover over the switches before power is turned on.**
- **Do not clean the product with chemicals such as benzene or thinners.**

2 General Instructions

2.1 Wiring

Warning

- **Adjusting, mounting or wiring change should not be done before disconnecting the power supply to the product.**
Electrical shock, malfunction and damage can result.
- **Do not disassemble the cables.**

- **Use only specified cables.**
- **Do not connect or disconnect the wires, cables and connectors when the power is turned on.**

Caution

- **Wire the connector correctly and securely.**
Check the connector for polarity and do not apply any voltage to the terminals other than those specified in the Operation Manual.
- **Take appropriate measures against noise.**
Noise in a signal line may cause malfunction. As a countermeasure separate the high voltage and low voltage cables, and shorten the wiring lengths, etc.
- **Do not route input/output wires and cables together with power or high voltage cables.**
The product can malfunction due to interference of noise and surge voltage from power and high voltage cables to the signal line. Route the wires of the product separately from power or high voltage cables.
- **Take care that actuator movement does not catch cables.**
- **Operate with all wires and cables secured.**
- **Avoid bending cables at sharp angles where they enter the product.**
- **Avoid twisting, folding, rotating or applying an external force to the cable.**
Risk of electric shock, wire breakage, contact failure and loss of control of the product can happen.
- **Select "Robotic cables" in case of inflecting cable (encoder/ motor/ rock) repeatedly.**
Refer to the "Driver operation manual" for the bending life due to the bending radius of the cable.

2 General Instructions (continued)

- **Confirm correct insulation of the product.**
Poor insulation of wires, cables, connectors, terminals etc. can cause interference with other circuits. Also there is the possibility that excessive voltage or current may be applied to the product causing damage.

2.2 Transportation

Caution

- **Do not carry or swing the product by the cables.**

2.3 Mounting

Warning

- **Observe the tightening torque for screws.**
Unless stated otherwise, tighten the screws to the recommended torque for mounting the product.
- **Do not make any alterations to this product.**
Alterations made to this product may lead to a loss of durability and damage to the product, which can lead to human injury and damage to other equipment and machinery.
- **When an external guide is used, connect the moving parts of the product and the load in such a way that there is no interference at any point within the stroke.**
Do not scratch or dent the sliding parts of the table or mounting face etc., by striking or holding them with other objects. The components are manufactured to precise tolerances, so that even a slight deformation may cause faulty operation or seizure.
- **Do not use the product until you verify that the equipment can be operated correctly.**
After mounting or repair, connect the power supply to the product and perform appropriate functional inspections to check it is mounted correctly.
- **When attaching to the work piece, do not apply strong impact or large moment.**
If an external force over the allowable moment is applied, it may cause looseness in the guide unit, an increase in sliding resistance or other problems.

- **Maintenance space**
Allow sufficient space for maintenance and inspection.

2.4 Handling

Warning

- **Do not touch the motor while in operation.**
The surface temperature of the motor can increase to approx. 80°C due to operating conditions.
Energizing alone may also cause this temperature increase.
As it may cause burns, do not touch the motor when in operation.
- **If abnormal heating, smoking or fire, etc. occurs in the product, immediately turn off the power supply.**
- **Immediately stop operation if abnormal operation noise or vibration occurs.**
If abnormal operation noise or vibration occurs, the product may have been mounted incorrectly. Unless operation of the product is stopped for inspection, the product can be seriously damaged.
- **Never touch the rotating part of the motor or the moving part of the actuator while in operation.**
There is a serious risk of injury.
- **When installing, adjusting, inspecting or performing maintenance on the product, driver and related equipment, be sure to turn off the power supply to each of them. Then, lock it so that no one other than the person working can turn the power on, or implement measures such as a safety plug.**

Caution

- **Keep the driver and product combined as delivered for use.**
The product is set in parameters for shipment.
If it is combined with a different product parameter, failure can result.

2 General Instructions (continued)

- **Check the product for the following points before operation.**
 - Damage to electric driving line and signal lines.
 - Looseness of the connector to each power line and signal line.
 - Looseness of the actuator/cylinder and driver mounting.
 - Abnormal operation.
 - Stop function
- **When more than one person is performing work, decide on the procedures, signals, measures and resolution for abnormal conditions before beginning the work.**
- **Also designate a person to supervise the work, other than those performing the work.**
- **An operation test should be performed at low speed, start the test at a predefined speed, after confirming there are no problems.**
- **Actual speed of the product will be changed by the workload.**
Before selecting a product, check the catalogue for the instructions regarding selection and specifications.
- **Do not apply a load, impact or resistance in addition to a transferred load during return to origin.**
In the case of the return to origin by pushing force, additional force will cause displacement of the origin position since it is based on detected motor torque.
- **Do not remove the nameplate.**

2.5 Actuator with lock

Warning

- **Do not use the lock as a safety lock or a control that requires a locking force.**
The lock used is designed to prevent dropping of work piece.
- **For vertical mounting, use the product with a lock.**
If the product is not equipped with a lock, the product will move and drop the work piece when the power is removed.
- **"Measures against drops," means preventing a work piece from dropping due to its weight when the product operation is stopped and the power supply is turned off.**

- **Do not apply an impact load or strong vibration while the lock is activated.**
If an external impact load or strong vibration is applied to the product, the lock will lose its holding force and damage to the sliding part of the lock or reduced lifetime can result. The same situation will happen when the lock slips due to a force higher than its holding force, as this will accelerate the wear to the lock.
- **Do not apply liquid, oil or grease to the lock or its surroundings.**
When liquid, oil or grease is applied to the sliding part of the lock, its holding force will be reduced significantly.
- **Take "measures against drops" and check that safety is assured before mounting, adjustment and inspection of the product.**
If the lock is released with the product mounted vertically, a work piece can drop due to its weight.

2.6 Please refer to the auto switch references in "Best Pneumatics" when an auto switch is to be used.

2.7 Unpacking

Caution

- **Check the received product is as ordered.**
If a different product is installed from the one ordered, injury or damage could result.

3 Specifications

Model		LEYG25/ LEYG25*D (Parallel / In-line)			LEYG32 (Parallel type)			LEYG32*D (In-line mounting)		
Stroke (mm) ^{Note1)}		30, 50, 100, 150, 200, 250,300	30, 50, 100, 150, 200, 250,300	30, 50, 100, 150, 200, 250,300	30, 50, 100, 150, 200, 250,300	30, 50, 100, 150, 200, 250,300	30, 50, 100, 150, 200, 250,300	30, 50, 100, 150, 200, 250,300	30, 50, 100, 150, 200, 250,300	30, 50, 100, 150, 200, 250,300
Work load (kg)	Horizontal ^{Note2)}	18	50	50	30	60	60	30	60	60
	Vertical	7	15	29	7	17	35	10	22	44
Pushing force (N) ^{Note3)}		65- 131	127- 255	242- 485	79- 157	154- 308	294- 588	98- 197	152- 385	368- 736
Maximum Speed (mm/s) ^{Note4)}		900	450	225	1200	600	300	1000	500	250
Pushing speed (mm/s) ^{Note4)}		35 or less			30 or less			30 or less		
Positioning repeatability (mm)	Basic type	± 0.02								
	High precision type	± 0.01								
Lost motion (mm) ^{Note8)}	Basic type	0.1 or less								
	High precision type	0.05 or less								
Lead (mm) ^{Included outlay ratio}		12	6	3	20	10	5	16	8	4
Impact resistance / vibration resistance (m/s ²) ^{Note5)}		50 / 20								
Drive method		Ball screw and Belt [1:1]/Ball screw			Ball screw and Belt [1.25:1]			Ball screw		
Guide type		Slide bearing (LEYG=L), Ball bushing bearing (LEYG=L)								
Operating temperature range (°C)		5 to 40								
Operating humidity range (%RH)		90 or less (No condensation)								
Motor output/size		100W/±40			200W/±60					
Elec. Itrc	Type of Motor	AC servo motor								
	Type ^{Note6)}	No excitation operating type								
Lock	Holding force (N)	131	255	485	157	308	588	197	385	736
	Power consumption (W) ^{Note7)} at 20°C	6.3 / 5.5			7.9 / 6			7.9 / 6		
	Rated voltage	24VDC ⁰ -10%								

- Note 1) Strokes other than the above are produced as a special order.
- Note 2) The maximum value of the horizontal workload (an external guide is necessary).The actual workload will depend on the type of external guide.
- Note 3) Thrust setting range when "pushing" operation in torque control mode, etc. Set it referring to the thrust conversion graph shown in the catalogue as a guide.
- Set value LEYG25*S/32*S: 15 to 30%
- Set value LEYG25*T/32*T: 12 to 24%

- Set value LEYG25*V/32*V: 45 to 90%
- Note 4) Allowable impact speed when "pushing" operation in torque control mode, etc.
- Note 5) Impact resistance:
No malfunction occurred when the actuator was tested with a drop tester in both an axial direction and perpendicular direction to the lead screw (The test was performed with the actuator in the initial state).
Vibration resistance:
No malfunction occurred in a test ranging between 45 to 2000 Hz, when the actuator was tested in both an axial direction and a perpendicular direction to the lead screw (The test was performed with the actuator in the initial state).
- Note 6) Only when the motor option, "with lock", is selected.
- Note 7) For an actuator with lock, add the power consumption for the lock.
- Note 8) A reference value for correcting an error in reciprocal operation.

Weight [kg]

Model	LEYG25M (Parallel type) / LEYG25L (Parallel type)						LEYG25MD (In-line mounting type) / LEYG25LD (In-line mounting type)							
	30	50	100	150	200	250	300	30	50	100	150	200	250	300
Incremental Encoder [S2]	1.8 / 1.8	2.0 / 2.0	2.3 / 2.3	2.7 / 2.7	3.1 / 3.1	3.4 / 3.4	3.7 / 3.7	1.8 / 1.8	2.0 / 2.0	2.3 / 2.3	2.8 / 2.8	3.1 / 3.1	3.4 / 3.4	3.7 / 3.7
Absolute Encoder [S6]	1.9 / 1.9	2.1 / 2.1	2.4 / 2.4	2.8 / 2.8	3.1 / 3.1	3.5 / 3.5	3.7 / 3.7	1.9 / 1.9	2.1 / 2.1	2.4 / 2.4	2.8 / 2.8	3.1 / 3.1	3.5 / 3.5	3.8 / 3.8
Absolute Encoder [T6]	1.8 / 1.9	2.0 / 2.1	2.3 / 2.4	2.8 / 3.1	3.1 / 3.5	3.7 / 3.7	1.9 / 1.9	2.1 / 2.1	2.4 / 2.4	2.8 / 2.8	3.1 / 3.1	3.5 / 3.5	3.7 / 3.7	3.8 / 3.8
Absolute Encoder [V6]	1.7 / 1.7	1.9 / 1.9	2.2 / 2.2	2.6 / 2.6	3.0 / 3.0	3.3 / 3.3	3.6 / 3.6	1.7 / 1.7	1.9 / 1.9	2.2 / 2.2	2.7 / 2.7	3.0 / 3.0	3.3 / 3.3	3.6 / 3.6

Model	LEYG32M (Parallel type) / LEYG32L (Parallel type)						LEYG32MD (In-line mounting type) / LEYG32LD (In-line mounting type)							
	30	50	100	150	200	250	300	30	50	100	150	200	250	300
Incremental Encoder [S3]	3.2 / 3.2	3.5 / 3.5	4.1 / 4.1	4.8 / 4.8	5.4 / 5.4	5.8 / 5.8	6.3 / 6.3	3.3 / 3.3	3.5 / 3.5	4.1 / 4.1	4.8 / 4.8	5.4 / 5.4	5.9 / 5.9	6.3 / 6.3
Absolute Encoder [S7]	3.2 / 3.2	3.4 / 3.4	4.0 / 4.0	4.7 / 4.7	5.3 / 5.3	5.8 / 5.8	6.2 / 6.2	3.2 / 3.2	3.5 / 3.5	4.0 / 4.0	4.8 / 4.8	5.3 / 5.3	5.8 / 5.8	6.2 / 6.2
Absolute Encoder [T7]	3.2 / 3.1	3.4 / 3.4	4.0 / 4.0	4.7 / 4.7	5.3 / 5.3	5.7 / 5.7	6.2 / 6.2	3.2 / 3.2	3.4 / 3.4	4.0 / 4.0	4.7 / 4.7	5.3 / 5.3	5.8 / 5.8	6.2 / 6.2
Absolute Encoder [V7]	3.1 / 3.1	3.4 / 3.4	4.0 / 4.0	4.7 / 4.7	5.3 / 5.3	5.7 / 5.7	6.2 / 6.2	3.2 / 3.2	3.4 / 3.4	4.0 / 4.0	4.7 / 4.7	5.3 / 5.3	5.8 / 5.8	6.2 / 6.2

Additional weight for lock [kg]

Size	25	32
Incremental Encoder [S2/S4]	0.2	0.4
Absolute Encoder [S6/S7]	0.3	0.7
Absolute Encoder [T6/T7]	0.3	0.4
Absolute Encoder [V6/V7]	0.3	0.6

4 Installation

4.1 Design and selection



Warning

- Do not apply a load in excess of the actuator specification. A product should be selected based on the maximum work load and allowable moment. If the product is used outside of the operating specification, the eccentric load applied to the guide will become excessive and have adverse effects such as creating play in the guide, reduced accuracy and reduced product life.
- Do not exceed the speed limit of the actuator specification. Select a suitable actuator by the relationship of allowable work load and speed. Noise or reduction of accuracy may occur if the actuator is operated in excess of its specification and could lead to reduced accuracy and reduced product life.
- Do not use the product in applications where excessive external force or impact force is applied to it. This can lead to premature failure of the product.

4.2 Handling



Caution

- Do not operate by fixing the piston rod and moving the actuator body. An excessive load will be applied to the piston rod, leading to damage to the actuator and reduced lifetime.
- Do not operate by fixing the piston rod and moving the actuator body. An excessive load will be applied to the piston rod, leading to damage to the actuator and reduced lifetime.

4.3 Mounting



Caution

- When mounting the product, use screws with adequate length and tighten them to the recommended torque.

Tightening to a torque over the specified range can cause operation failure, and insufficient torque can cause displacing or dropping of the attachment.

Work fixed/ Plate tapped style

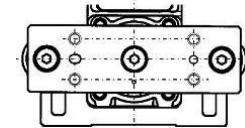

Model	Screw	Max. tightening torque [Nm]	Max. thread depth [mm]
LEYG25 ^M _L	M6 x 1.0	5.2	11
LEYG32 ^M _L	M6 x 1.0	5.2	12

- Tighten the product mounting screws to the specified torque. Tightening to a torque over the specified range can cause operation failure, and insufficient torque can cause displacing or dropping of the attachment.

Mounting / Upper mounting tapped style

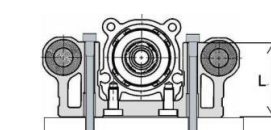

Model	Screw	Max. tightening torque [Nm]	Length L [mm]
LEYG25 ^M _L	M5 x 0.8	3.0	40.3
LEYG32 ^M _L	M5 x 0.8	3.0	50.3

Mounting / Lower mounting tapped style

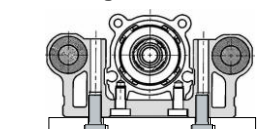

Model	Screw	Max. tightening torque [Nm]	Max. thread depth [mm]
LEYG25 ^M _L	M6 x 1.0	5.2	12
LEYG32 ^M _L	M6 x 1.0	5.2	12

Mounting / Head side tapped style

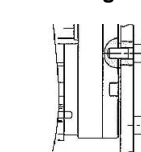

Model	Screw	Max. tightening torque [Nm]	Max. thread depth [mm]
LEYG25 ^M _L	M8 x 0.8	3.0	8
LEYG32 ^M _L	M8 x 1.0	5.2	10

5 Names and Function of Individual Parts

Parallel motor type

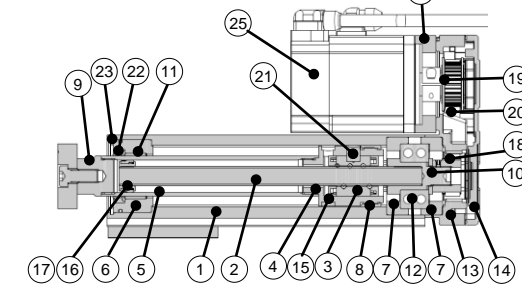

LEYG0M

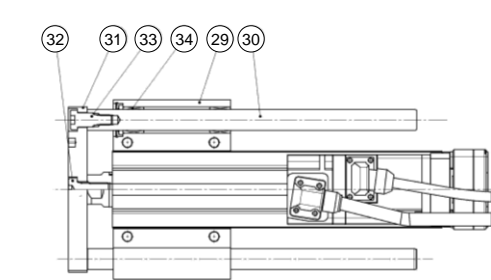

LEYG0L

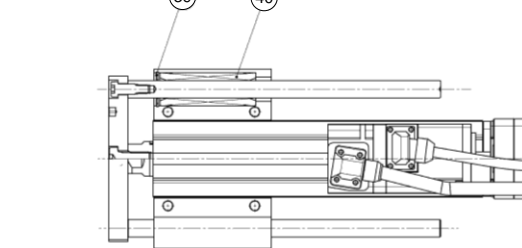

LEYG25/32M: 50 stroke or less



LEYG25/32M: Over 50 stroke



LEYG25/32L 100 stroke or less

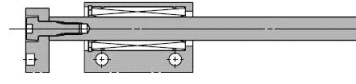

LEYG25/32L: Over 100 stroke

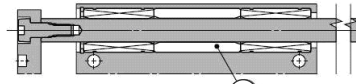

When "Grease maintenance mechanism" is selected

LEYG25/3 M: 50 stroke or less

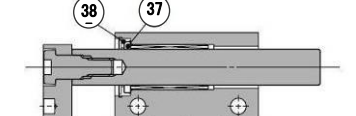

LEYG25/32M: Over 50 stroke

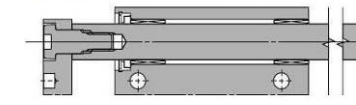

5 Names and function of Individual Parts (continued)

No.	Part	Material	Remarks
1	Body	Aluminium alloy	Anodized
2	Ball screw shaft	Alloy steel	
3	Ball screw nut	-	
4	Piston	Aluminium alloy	
5	Piston rod	Stainless steel	Hard chrome anodized
6	Rod cover	Aluminium alloy	
7	Bearing holder	Aluminium alloy	
8	Rotation stopper	POM	
9	Socket	Free cutting carbon steels	Nickel plated
10	Connected shaft	Free cutting carbon steels	Nickel plated
11	Bushing	Lead bronze cast	
12	Bearing	-	
13	Pulley box	Aluminium die-cast	Non-Hexavalent chromated
14	Pulley plate	Aluminium die-cast	Non-Hexavalent chromated
15	Magnet	-	
16	Wear ring holder	Stainless steel	Only stroke 101 mm or more
17	Wear ring	POM	Only stroke 101 mm or more
18	Pulley(for Screw shaft)	Aluminium alloy	
19	Pulley (for motor)	Aluminium alloy	
20	Belt	-	
21	Parallel pin	Stainless steel	
22	Rod seal	NBR	
23	Retaining ring	Steel for spring	
24	Motor adapter	Aluminium alloy	Anodized
25	Motor	-	
26	Motor block	Aluminium alloy	Anodized
27	Hub	Aluminium alloy	Hub
28	Spider	Urethane	Spider
29	Guide attachment	Aluminium alloy	Anodized
30	Guide rod	Carbon steel	Hard chrome plated
31	Plate	Aluminium alloy	Anodized
32	Plate mounting screw	Carbon tool steel	Nickel plated
33	Guide screw	Carbon tool steel	Nickel plated

36	Slide Bearing	Babbitt	
37	Felt	Felt	
38	Holder	Resin	
39	Retaining ring	Carbon tool steel	Phosphate coated
40	Ball bushing		
41	Spacer	Aluminium alloy	

6 Wiring

LECSA (Pulse input / Positioning) driver

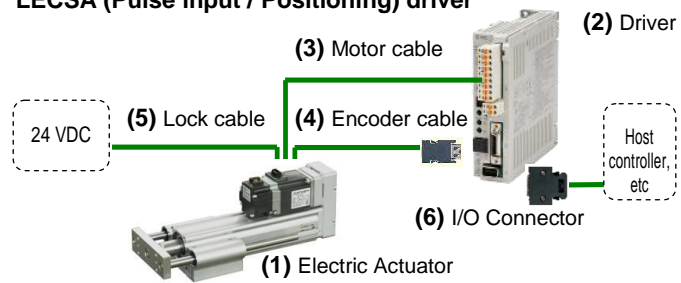

LECSB (Pulse input) driver LECS (CC-Link) driver LECS (SSCNET) driver

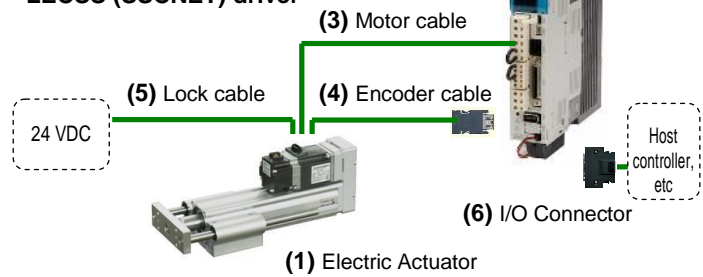

LECYM/LECYU (MECHATROLINK) driver

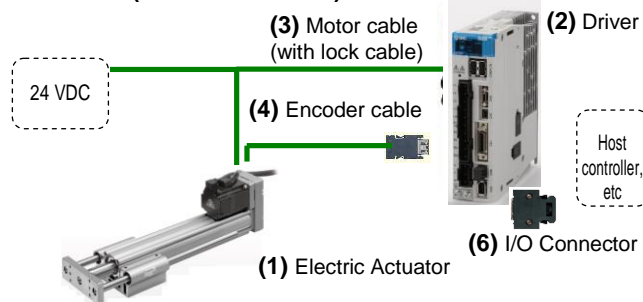

Warning

Use only specified cables otherwise there may be risk of fire and damage

7 Maintenance

Warning

- **Do not disassemble or repair the product.**
Fire or electric shock can result.
- **Before modifying or checking the wiring, the voltage should be checked with a tester 5 minutes after the power supply is turned off.**
Electrical shock can result.

Caution

- **Maintenance should be performed according to the procedure indicated in the Operating Manual.**
Incorrect handling can cause an injury, damage or malfunction of equipment and machinery.
- **Removal of product.**
When equipment is serviced, first confirm that measures are in place to prevent dropping of work pieces and run-away of equipment, etc. and then turn off the power supply to the system.
When machinery is restarted, check that operation is normal with actuators in the correct positions.

7 Maintenance (continued)

- **The product has been lubricated for life at manufacture, and does not require lubrication in service.**
Contact SMC if lubrication will be applied.
Please read the maintenance manual for each actuator.
- **Maintenance frequency.**
Perform maintenance according to the table below.
Contact SMC if any abnormality is found.

	Appearance check	Belt check
Inspection before daily operation	○	○
Inspection every 6 months / 250 km / 5 million cycles *	○	○
Inspection every 5 million cycles / yearly *	○	○

* Whichever occurs first

- **Items for visual appearance check.**
Loose screws, abnormal dirt.
Check of flaws and cable joint.
Vibration, noise.
- **Items for belt check**
Check the belt regularly as shown in "maintenance frequency".
Stop operation immediately and contact SMC when the belt appears to be like the photographs shown below.
- **Tooth shape canvas is worn out**
Canvas fibre becomes fuzzy.
Rubber is removed and the fibre becomes whitish.
Lines of fibres become unclear.



Teeth become fuzzy

- **Peeling off or wearing of the side of the belt**
Belt corner becomes round and frayed threads stick out.



- **Belt partially cut**
Belt is partially cut;

Foreign matter caught in teeth other than cut part causes flaw.

- **Vertical line of belt teeth**
Flaw which is made when the belt runs on the flange.
- **Rubber back of the belt is softened and sticky.**
- **Crack on the back of the belt.**

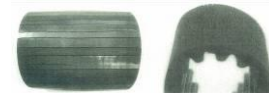

8 CE Directive

- **Electromagnetic Compatibility (EMC) Directive**
The LE series actuators and motor drivers conform to the EMC directive, if they are installed in accordance with the following instructions.
These components are intended for incorporation into machinery and assemblies forming part of a larger system.
The CE compliance was achieved when the above two components were connected as shown in the diagram below.

Please note that the EMC performance changes according to the configuration of the customers control panel and the relationship with other electrical equipment and wiring.
Therefore conformity to the EMC directive cannot be certified for SMC components incorporated into the customer's equipment under actual operating conditions. As a result it is necessary for the customer to verify conformity to the EMC directive for the machinery and equipment as a whole.

- **Low Voltage Directive (LVD)**
The LE series of actuators and drivers are in compliance with the LVD.
Please refer to the relevant manuals for installation guidelines.

- **Grounding the actuator and the driver**
Please refer to the IMM of the LEC driver used along with the actuator for the information of grounding.

8 CE Directive(continued)

- **Location of grounding point**
IF the actuator needs the ground that is bolted, see below figure.
The bolt, cable with crimping terminal and toothed washer should be obtained separately.

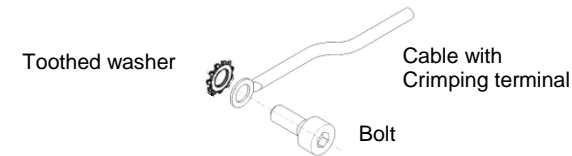

Location of grounding point

Parallel motor type

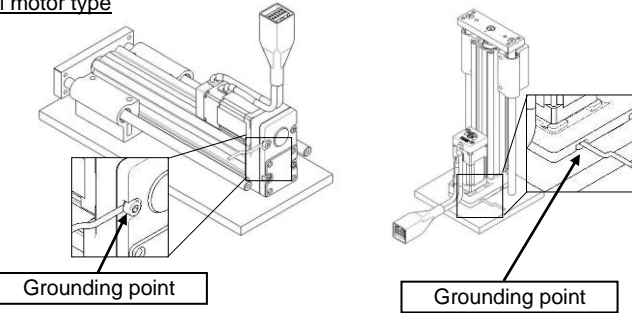

In-line motor type

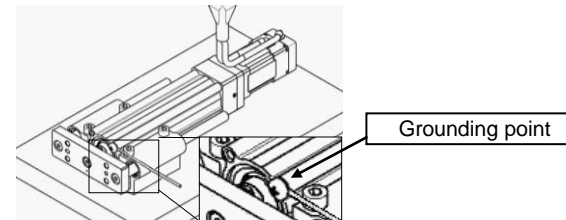

9 Contacts

AUSTRIA	(43) 2262 62280-0	LATVIA	(371) 781 77 00
BELGIUM	(32) 3 355 1464	LITHUANIA	(370) 5 264 8126
BULGARIA	(359) 2 974 4492	NETHERLANDS	(31) 20 531 8888
CZECH REP.	(420) 541 424 611	NORWAY	(47) 67 12 90 20
DENMARK	(45) 7025 2900	POLAND	(48) 22 211 9600
ESTONIA	(372) 651 0370	PORTUGAL	(351) 21 471 1880
FINLAND	(358) 207 513513	ROMANIA	(40) 21 320 5111
FRANCE	(33) 1 6476 1000	SLOVAKIA	(421) 2 444 56725
GERMANY	(49) 6103 4020	SLOVENIA	(386) 73 885 412
GREECE	(30) 210 271 7265	SPAIN	(34) 945 184 100
HUNGARY	(36) 23 511 390	SWEDEN	(46) 8 603 1200
IRELAND	(353) 1 403 9000	SWITZERLAND	(41) 52 396 3131
ITALY	(39) 02 92711	UNITED KINGDOM	(44) 1908 563888

SMC Corporation

URL : [http:// www.smcworld.com](http://www.smcworld.com) (Global) [http:// www.smceu.com](http://www.smceu.com) (Europe)
Specifications are subject to change without prior notice from the manufacturer.
© 2016 SMC Corporation All Rights Reserved.