

Traffa

Bedienhandbuch
Elektr. Antriebe Miniaturausführung LEP



TRAFFA
TECHNISCHES BÜRO



Innovative Antriebslösungen

Der optimale Antrieb individuell für Ihre Anforderung



Operation Manual

PRODUCT NAME

Electric Actuator Miniature Rod Type Miniature Slide table Type

MODEL / Series / Product Number

LEP Series

Applicable models: LEPY[], LEPS[],

LEPY Series

(Rod type)



LEPS Series

(Slide table type)

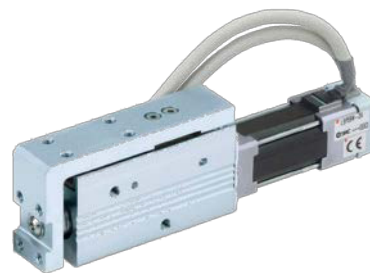

<Controller>
LEC Series



This manual describes the actuators operation in combination with the LEC*6 series controllers. Refer to the manual relevant to the controller being used for full operating instructions.

SMC Corporation

Safety Instructions	2
1. Procedure before operation/simple setting to use straight away4	
1.1 Preparation	4
1.2 Controller setting software version.....	5
1.3 Teaching box.....	7
2. Electric Actuator / Miniature Rod type.....	9
2.1 Specification.....	9
2.2 How to Order	10
2.3 Construction.....	11
3. Electric Miniature Actuator / Slide table type.....	12
3.1 Specification.....	12
3.2 How to Order	13
3.3 Construction.....	14
4. Product Outline	15
4.1 System construction	15
4.2 Setting Function.....	16
4.3 Step data setting method	19
4.4 Parameter setting method.....	30
5. Wiring of cables / Common precautions.....	33
6. Electric actuators / Common precautions	34
6.1 Design and selection	34
6.2 Mounting.....	35
6.3 Handling	36
6.4 Operating environment	37
6.5 Maintenance	38
6.6 Precautions for actuator with lock	38
7. Electric actuators / Common precautions	39
7.1 Design and selection	39
7.2 Mounting.....	39
7.3 Handling	42
7.4 Precaution on maintenance	44
8. Troubleshooting	45



LEP Series / Electric Actuator Safety Instructions

These safety instructions are intended to prevent hazardous situations and/or equipment damage. These instructions indicate the level of potential hazard with the labels of "Caution," "Warning" or "Danger." They are all important notes for safety and must be followed in addition to International Standards (ISO/IEC)*1), and other safety regulations.

*1) ISO 4414: Pneumatic fluid power -- General rules relating to systems

ISO 4413: Hydraulic fluid power -- General rules relating to systems

IEC 60204-1: Safety of machinery -- Electrical equipment of machines (Part 1: General requirements)

ISO 10218-1: Manipulating industrial robots -Safety.

etc.



Caution

Caution indicates a hazard with a low level of risk which, if not avoided, could result in minor or moderate injury.



Warning

Warning indicates a hazard with a medium level of risk which, if not avoided, could result in death or serious injury.



Danger

Danger indicates a hazard with a high level of risk which, if not avoided, will result in death or serious injury.

Warning

1. The compatibility of the product is the responsibility of the person who designs the equipment or decides its specifications.

Since the product specified here is used under various operating conditions, its compatibility with specific equipment must be decided by the person who designs the equipment or decides its specifications based on necessary analysis and test results.

The expected performance and safety assurance of the equipment will be the responsibility of the person who has determined its compatibility with the product.

This person should also continuously review all specifications of the product referring to its latest catalog information, with a view to giving due consideration to any possibility of equipment failure when configuring the equipment.

2. Only personnel with appropriate training should operate machinery and equipment.

The product specified here may become unsafe if handled incorrectly.

The assembly, operation and maintenance of machines or equipment including our products must be performed by an operator who is appropriately trained and experienced.

3. Do not service or attempt to remove product and machinery/equipment until safety is confirmed.

1. The inspection and maintenance of machinery/equipment should only be performed after measures to prevent falling or runaway of the driven objects have been confirmed.

2. When the product is to be removed, confirm that the safety measures as mentioned above are implemented and the power from any appropriate source is cut, and read and understand the specific product precautions of all relevant products carefully.

3. Before machinery/equipment is restarted, take measures to prevent unexpected operation and malfunction.

4. Contact SMC beforehand and take special consideration of safety measures if the product is to be used in any of the following conditions.

1. Conditions and environments outside of the given specifications, or use outdoors or in a place exposed to direct sunlight.

2. Installation on equipment in conjunction with atomic energy, railways, air navigation, space, shipping, vehicles, military, medical treatment, combustion and recreation, or equipment in contact with food and beverages, emergency stop circuits, clutch and brake circuits in press applications, safety equipment or other applications unsuitable for the standard specifications described in the product catalog.

3. An application which could have negative effects on people, property, or animals requiring special safety analysis.

4. Use in an interlock circuit, which requires the provision of double interlock for possible failure by using a mechanical protective function, and periodical checks to confirm proper operation.



LEP Series / Electric Miniature Actuator Safety Instructions

Caution

1. The product is provided for use in manufacturing industries.

The product herein described is basically provided for peaceful use in manufacturing industries. If considering using the product in other industries, consult SMC beforehand and exchange specifications or a contract if necessary.
If anything is unclear, contact your nearest sales branch.

Limited warranty and Disclaimer/Compliance Requirements

The product used is subject to the following “Limited warranty and Disclaimer” and “Compliance Requirements”.

Read and accept them before using the product.

Limited warranty and Disclaimer

1. The warranty period of the product is 1 year in service or 1.5 years after the product is delivered.*2)

Also, the product may have specified durability, running distance or replacement parts. Please consult your nearest sales branch.

2. For any failure or damage reported within the warranty period which is clearly our responsibility, a replacement product or necessary parts will be provided.

This limited warranty applies only to our product independently, and not to any other damage incurred due to the failure of the product.

3. Prior to using SMC products, please read and understand the warranty terms and disclaimers noted in the specified catalog for the particular products.

***2) Vacuum pads are excluded from this 1 year warranty.**

A vacuum pad is a consumable part, so it is warranted for a year after it is delivered. Also, even within the warranty period, the wear of a product due to the use of the vacuum pad or failure due to the deterioration of rubber material are not covered by the limited warranty.

Compliance Requirements

1. The use of SMC products with production equipment for the manufacture of weapons of mass destruction (WMD) or any other weapon is strictly prohibited.

2. The exports of SMC products or technology from one country to another are governed by the relevant security laws and regulation of the countries involved in the transaction. Prior to the shipment of a SMC product to another country, assure that all local rules governing that export are known and followed.

1. Procedure before operation/simple setting to use straight away

The controller is already set with the data of the actuator.

With the simple setting “easy mode”, it can be operated and running parameters can be changed easily.

1.1 Preparation

(1) Items to be prepared

Please check on the label, and the quantity of accessories, to confirm that it is the product that was ordered.

Table 1. Components

No.	Part name	Qty
(1)	Electric Actuator	1
(2)	Controller	1
(3)	Power supply plug	1
(4)	Actuator cable	1
(5)	I/O cable (Not use in this section)	1
(6)	Teaching box	1
(7)	Controller setting kit [The controller setting software, The communication cable, USB cable and conversion unit are included.]	1

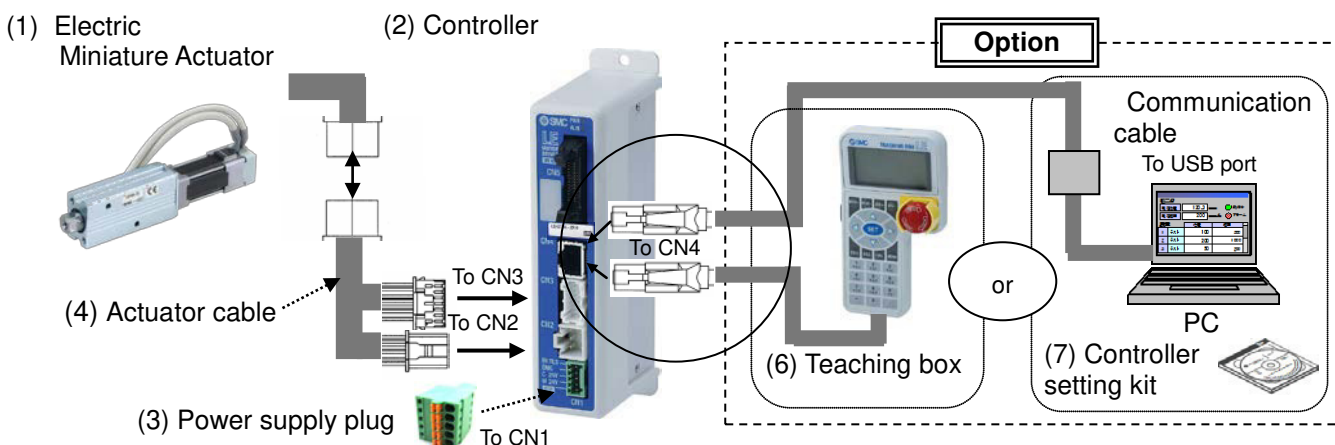
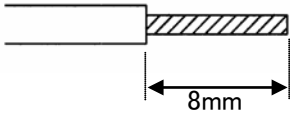
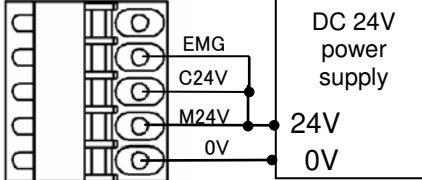
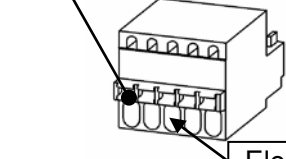

Table 2. Items to be prepared by the customer

Part name	Conditions
Power supply 24VDC Do not use the power supply with “Inruch-restraining type”	Refer to power consumption of each actuator / See 2.1 Specification [LEPY] on p.9, 3.1 Specification [LEPS] on p.12 (Prepare the power supply that has capacity of “Moment max.power consumption” or more.)
Wire AWG20 (0.5mm ²)	Stripped wire length 
Power supply plug Wiring	Connect the plus side of DC 24V to the C24V, M24V and EMG terminals of the power supply plug, and the minus side to the 0V terminal. When conformity to UL is required, the electric actuator and controller should be used with a UL1310 Class 2 power supply.  Push the open/ close lever and insert the wire into the electrical wire entry. 

1.2 Controller setting software version

1. Installation of software

With the controller setting software CD-ROM, install the communication unit software, following the "Software Installation procedure" (PDF)

2. Startup of software

After turning on the controller power supply, start up the ACT Controller setting software.

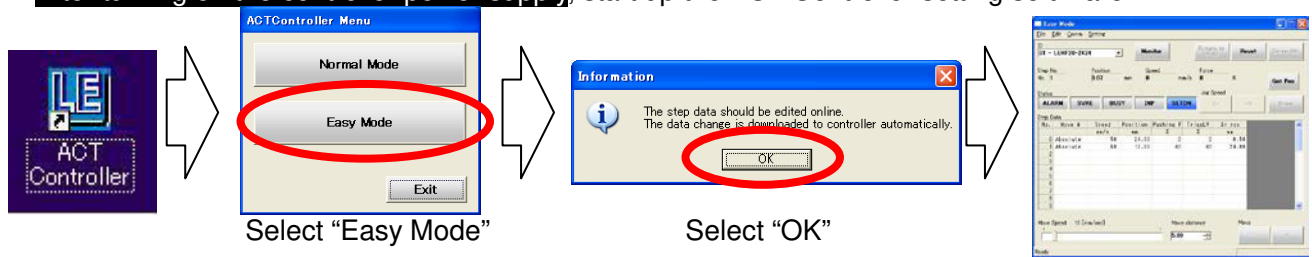

3. JOG Drive

a. Driving preparation: Servo On → Return to ORIG

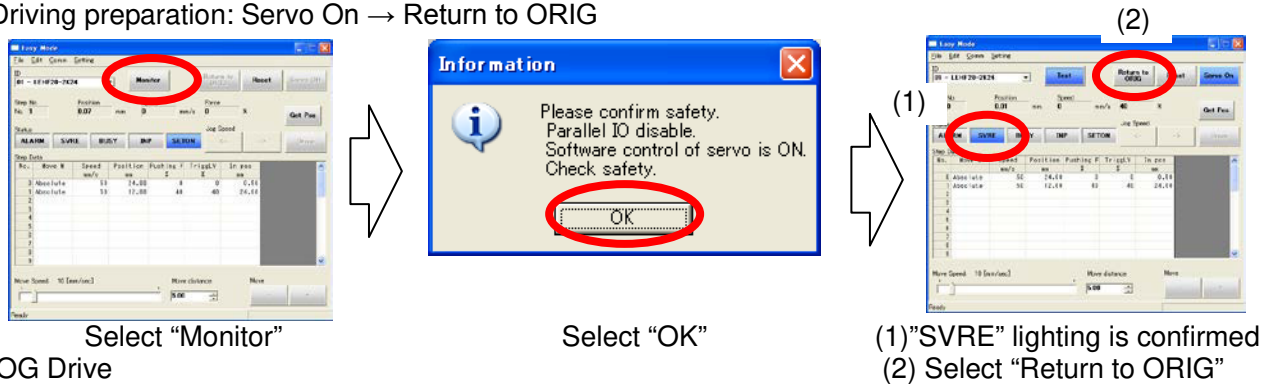

b. JOG Drive

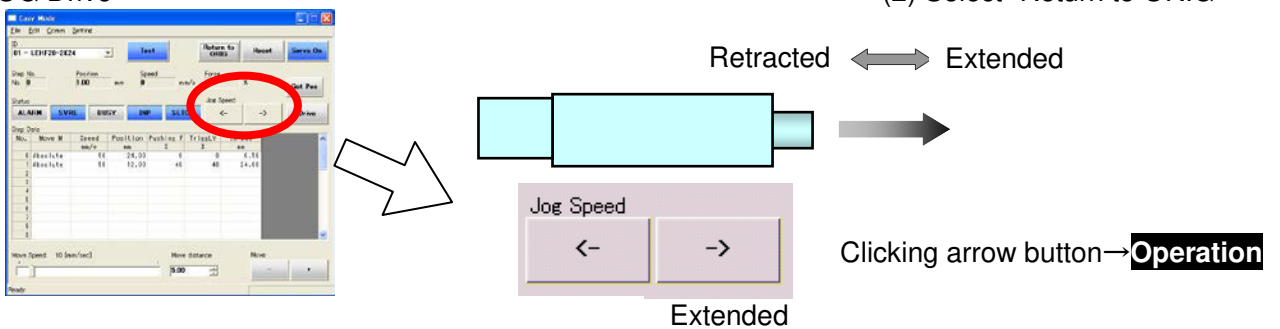

c. Driving stop: Servo Off

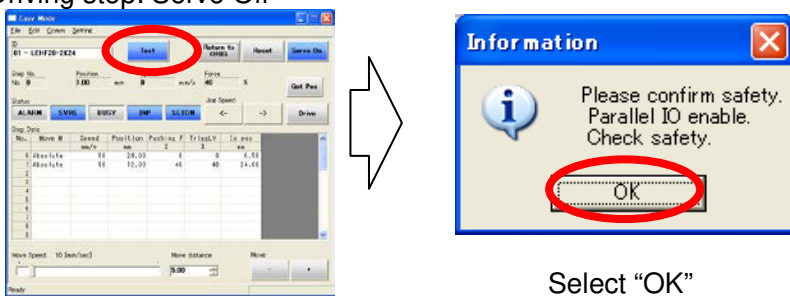

⚠ Caution

If an alarm is generated

(1) When "ALARM" is generated, release it by selecting (2) Reset.

In the case of an alarm code that cannot be released with "Reset", turn the power supply OFF and ON again. (1)

Note) For details of alarm codes, refer to the Controller Operation Manual.



4. TEST Drive / Step No.0 → No.1 → No.0...

a. Driving preparation: Servo On → Return to ORIG / Refer to “3.JOG Drive”.

b. TEST Drive

“Step No.0” Operation

Procedure 1:
Select “Step No.0”
You can select anywhere in the row

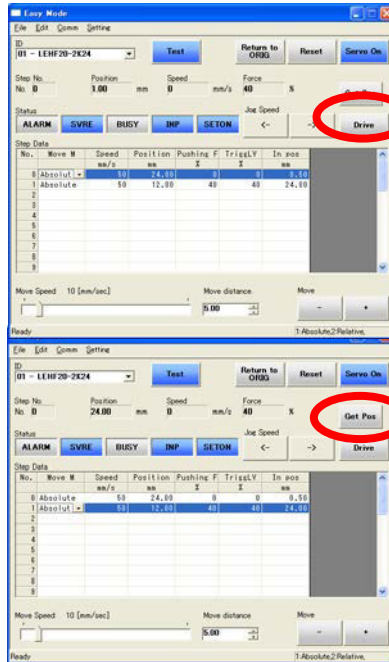

Procedure 2:
Select “Drive”

→ **Operation**

“Step No.1” Operation

Procedure 3:
Select “Step No.1”
You can select anywhere in the row



Procedure 4:
Select “Drive”

→ **Operation**

c. Driving stop : Servo Off / Refer to “3.JOG Drive”.

5. Step data change

Ex) “Step No.0” / Pushing operation

No.	Move M	Speed	Position	Pushing F	TriggLV	In pos
		mm/s	mm	%	%	mm
0	Absolute	100	20.00	70	70	25.00

Change of pushing start position

Position: 20mm → 10mm

Change of pushing force

Pushing force: 70% → 100%

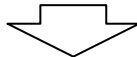

Input “10” Input “100”

No.	Move M	Speed	Position	Pushing F	TriggLV	In pos
		mm/s	mm	%	%	mm
0	Absolute	100	10.00	100	70	25.00

Ex) “Step No.1” / Positioning operation

No.	Move M	Speed	Position	Pushing F	TriggLV	In pos
		mm/s	mm	%	%	mm
0	Absolute	100	20.00	70	70	25.00
1	Absolute	100	0.00	0	0	0.50

Change of positioning stop position

Position: 0mm → 5mm

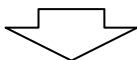

Input “5”

No.	Move M	Speed	Position	Pushing F	TriggLV	In pos
		mm/s	mm	%	%	mm
0	Absolute	100	20.00	70	70	20.00
1	Absolute	100	5.00	0	0	0.50

For details of operation, and relationship between operation procedure and input/output signals, refer to “4.3 Step Data setting method” p. 19 to 27.

6. Controller setting software screen explanation

Refer to the “Help / Easy mode” menu in the “ACT Controller” setting software.

1.3 Teaching box

1. Name

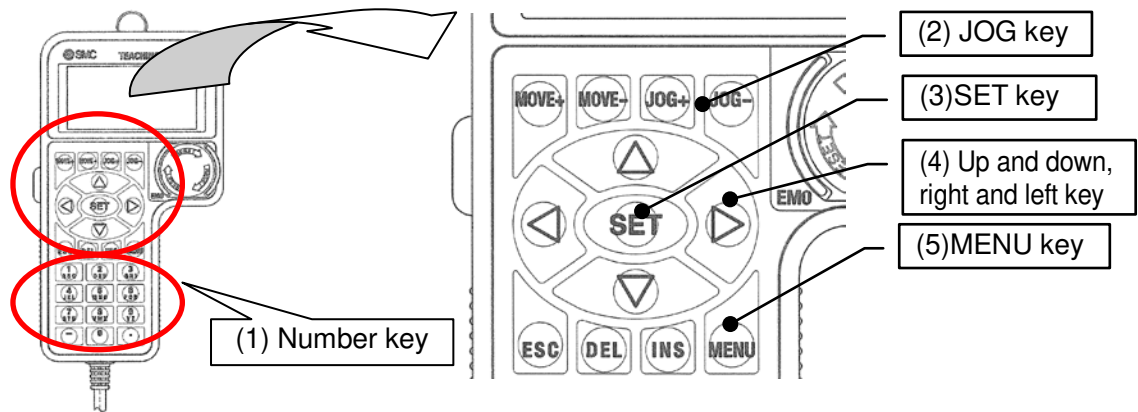

2. JOG Drive

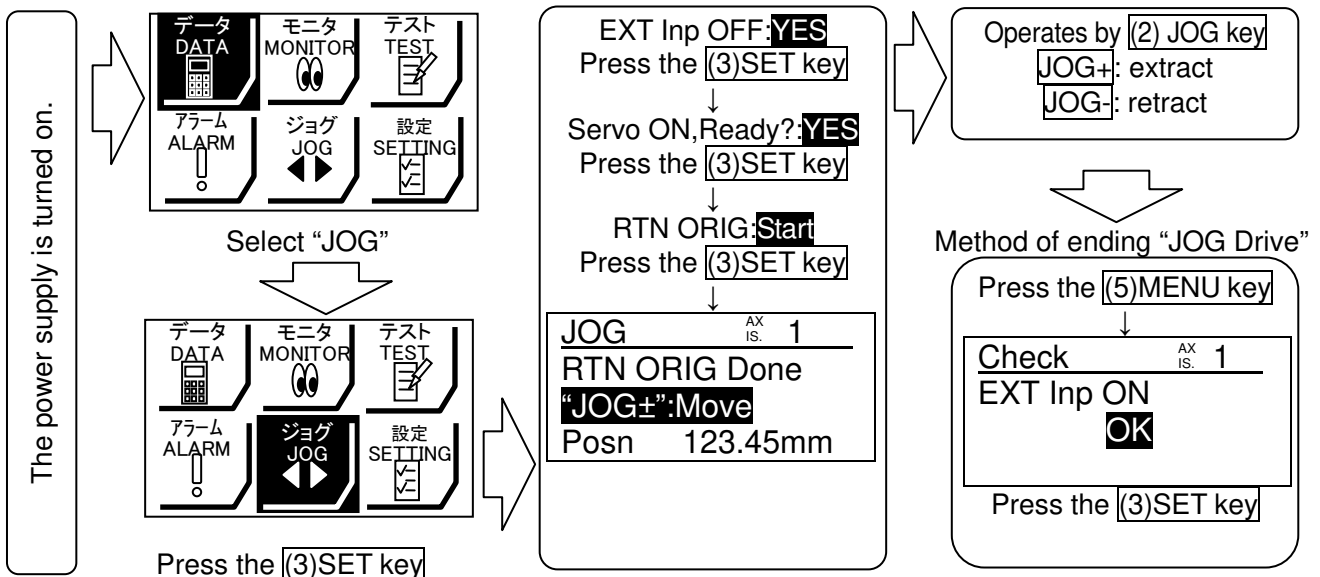

3. TEST Drive / Step No.0 → No.1 → No.0...

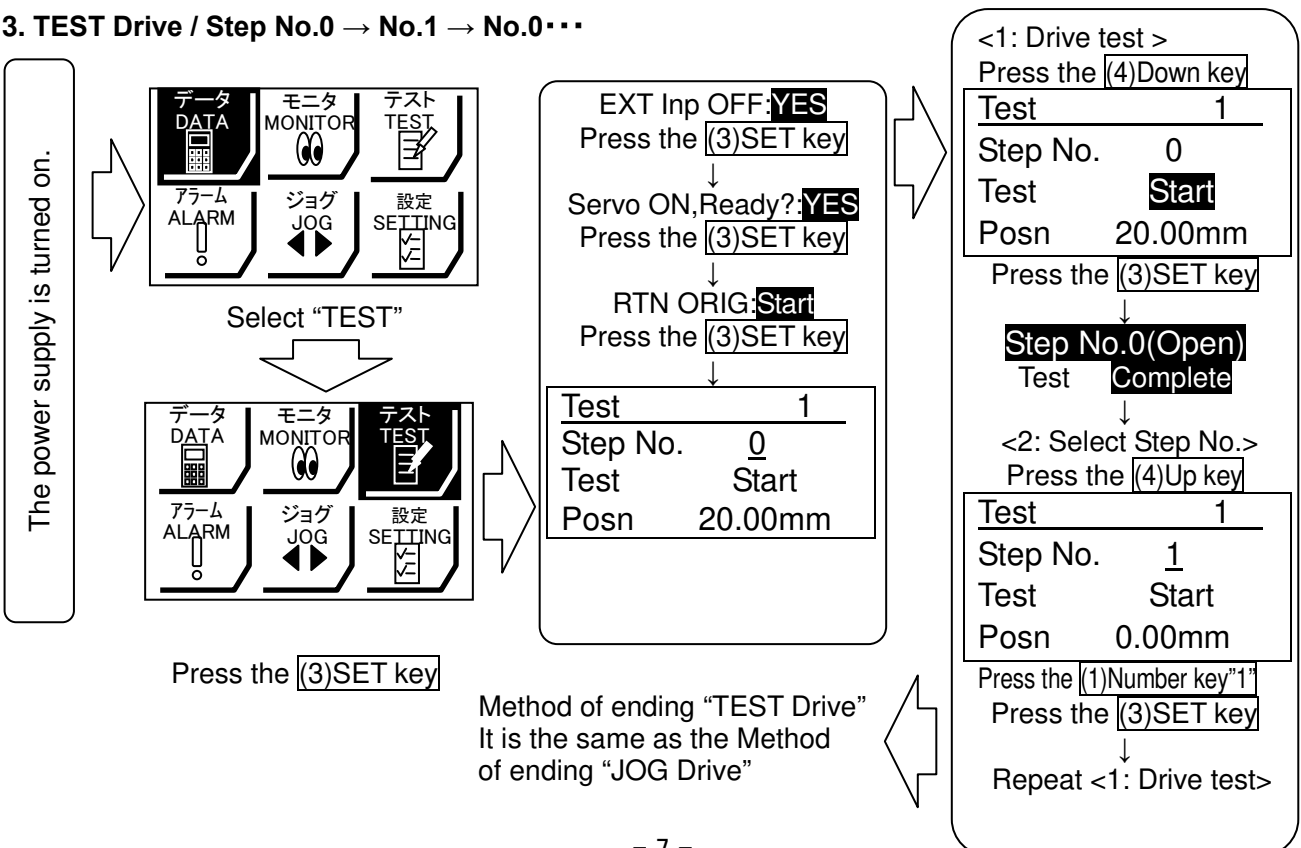

4. Step data change

“Step No.0” / Pushing operation

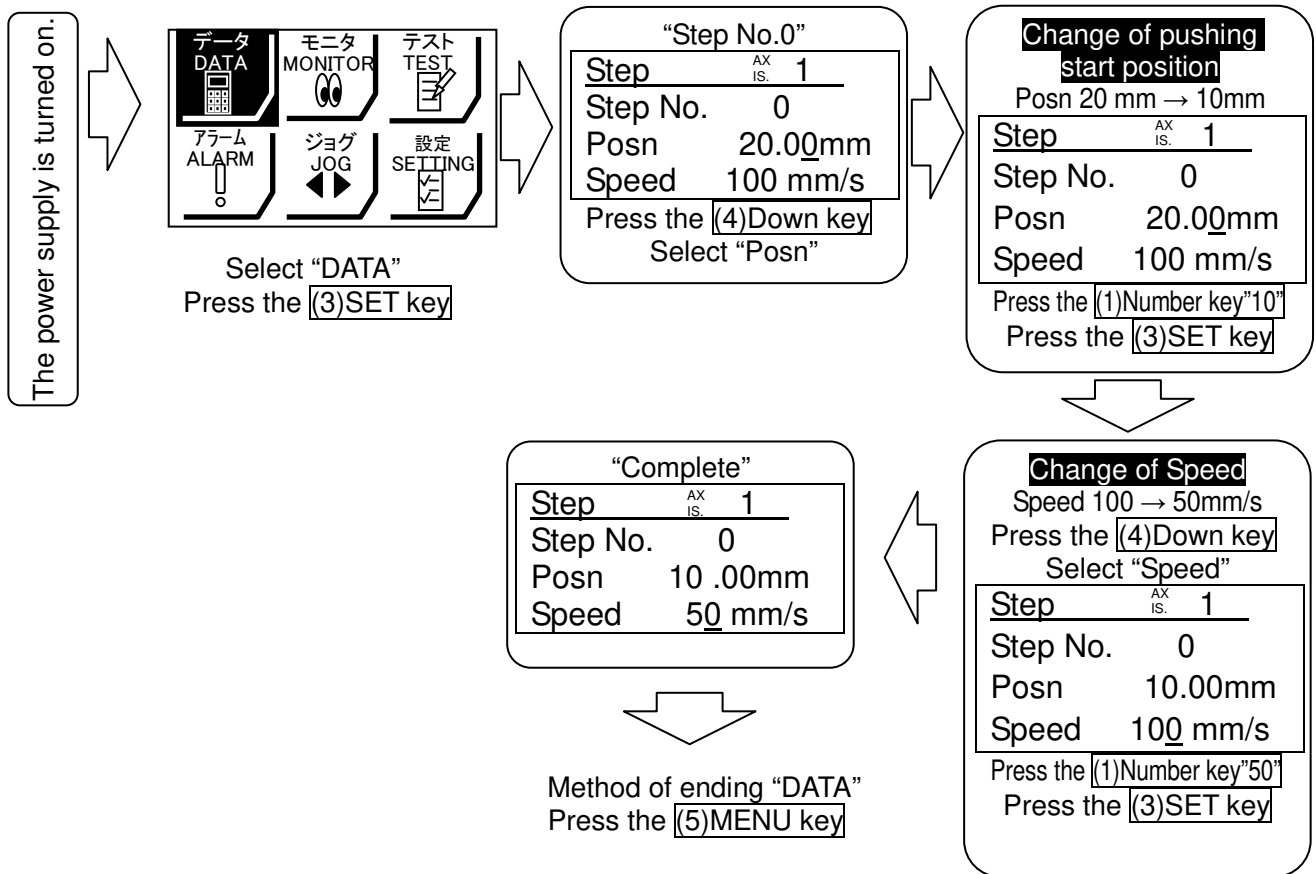

“Step No.1” / Positioning operation

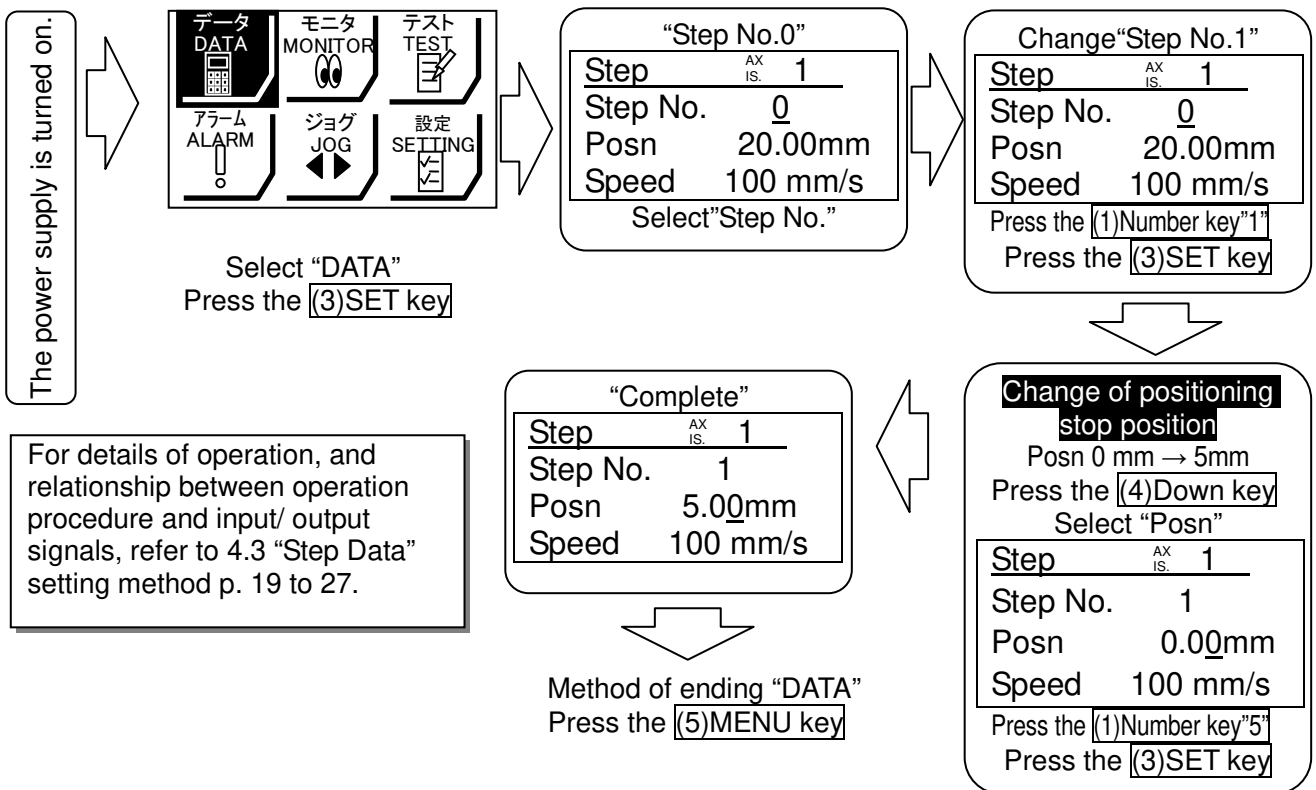

5. Teaching box detailed explanation

Please refer to the teaching box manual.

2. Electric Actuator / Miniature Rod type

2.1 Specification

Model			LEPY 6			LEPY 10		
Actuator specification	Stroke [mm]		25, 50, 75					
	Screw lead [mm]		4	8	5	10		
	Pushing force [N] Note1) Note6)		Basic	14 ~ 20	7 ~ 10	25 ~ 50	12.5 ~ 25	
			Compact	-	-	24 ~ 40	12 ~ 20	
	Work load [kg] Note2) Note3) Note6)	Horizontal	Basic	2	1	6	3	
			Compact	-	-	4	2	
		Vertical	Basic	0.5	0.25	1.5	1.0	
			Compact	-	-	1.5	1.0	
	Speed [mm/s] Note3) Note6)	Horizontal	Basic	10 to 150	20 to 300 ^{Note4)}	10 to 200	20 to 350 ^{Note4)}	
			Compact	-	-	10 to 200	20 to 350 ^{Note4)}	
		Vertical	Basic	10 to 150	20 to 300 ^{Note4)}	10 to 150	20 to 300 ^{Note4)}	
			Compact	-	-	10 to 150	20 to 300 ^{Note4)}	
	Pushing speed [mm/s] ^{Note5)}		10	20	10	20		
	Acceleration / Deceleration [mm/s ²]		3000					
	Backlash [mm]		0.2 or less					
	Positioning repeatability [mm]		+/- 0.05					
	Lost motion [mm] ^{Note7)}		0.2 or less					
	Impact resistance/vibration Resistance [m/s ²] ^{Note8)}		50 / 20					
Actuation type		Sliding screw						
Guide type		Sliding bush						
Max. operating frequency (c.p.m)		60						
Operating temperature range [°C]		5 to 40						
Operating humidity range [%RH]		90 or less(No condensation)						
Electric specification	Motor size		□20			□28		
	Motor type		Step motor (Servo 24VDC)					
	Encoder		Incremental A/B phase (800 pulse/rotation)					
	Rated voltage [VDC]		24 +/- 10%					
	Power consumption [W] Note9)	Basic	12			28		
		Compact	-			22		
	Standby power consumption when operating [W] ^{Note10)}	Basic	11			22		
		Compact	-			16		
Max. instantaneous power consumption [W] ^{Note11)}	Basic	22			55			
	Compact	-			45			

Model		LEPY 6			LEPY 10		
Stroke [mm]		25	50	75	25	50	75
Weight [kg]	Basic	0.24	0.29	0.34	0.47	0.55	0.65
	Compact	-	-	-	0.41	0.49	0.59

Note 1) Pushing force accuracy is LEPY6: ±30% (F.S.), LEPY10: ±25% (F.S.).

The pushing force and the duty ratio change according to the set value. Refer to the catalog.

Note 2) The maximum value of the work load for the positioning operation. An external guide is necessary to support the load.

The actual work load and transfer speed change according to the condition of the external guide.

Note 3) Speed changes according to the work load. Refer to the catalog.

Note 4) When the stroke is 25 mm, the maximum speed will be 250 mm/sec.

Note 5) Set to the pushing speed when pushing operation.

Note 6) The speed and force may change depending on the cable length, load and mounting conditions. Furthermore, if the cable length exceeds 5 m, then it will decrease by up to 10% for each 5 m. (At 15 m: Reduced by up to 20%)

Note 7) A reference value for correcting an error in reciprocal operation.

Note 8) Impact resistance: No malfunction occurred when the actuator was tested with a drop tester in both an axial direction and a perpendicular direction to the lead screw. (Test was performed with the actuator in the initial state.)

Vibration resistance: No malfunction occurred in a test ranging between 45 to 2000 Hz. Test was performed in both an axial direction and a perpendicular direction to the lead screw.

(Test was performed with the actuator in the initial state.)

Note 9) The power consumption (including the controller) is for when the actuator is operating.

Note 10) The standby power consumption when operating (including the controller) is for when the actuator is stopped in the set position during operation. Except during the pushing operation.

Note 11) The maximum instantaneous power consumption (including the controller) is for when the actuator is operating. This value can be used for the selection of the power supply.

2.2 How to Order

LEPY **10** **K** - **50** - **R** **1** **6N** **1**

① ② ③ ④ ⑤ ⑥ ⑦ ⑧ ⑨ ⑩

① Size

6
10

② Motor size

Nil	Basic
L	Compact *

* Size: 10 only

③ Lead screw type(mm)

Symbol	Screw lead	
	LEPS6	LEPS10
K	4	5
J	8	10

④ Stroke(mm)

記号	ストローク
25	25
50	50
75	75

⑤ Motor cable mounting direction

Nil	Top type
R	Entry on the right side
L	Entry on the left side
U	Bottom entry

⑥ Actuator cable*1

Nil	Without cable
S	Standard cables
R	Robotic type cables (Flexible type cables)

*1 The standard cable should be used on fixed parts.

For using on moving parts, select the robotic cable.

*2 Fix the motor cable protruding from the actuator to keep it unmovable. For details about fixing method, refer to Wiring/Cables in the Electric Actuators Precautions.

⑦ Actuator cable length(m)

Nil	Without cable	8	8 *
1	1.5	A	10 *
3	3	B	15 *
5	5	C	20 *

* produced upon receipt of order.

(Only "Robotic type cables" can be selected.)

⑧ Controller /Driver type *

Nil	Without controller	
6N	LECP6	NPN
6P	(Step date input type)	PNP
1N	LECP1	NPN
1P	(Program-less type)	PNP
MJ	LECPMJ (CC-link direct input type)	-
AN	LECPA	NPN
AP	(Pulse input type)	PNP
C9	JXC9 (EtherNet/IP direct input type)	-

* For details about controllers/driver and compatible motors, refer to the compatible controllers/driver below.

⑨ I/O cable length [m] / 6* 1* A* *

Nil	Without cable
1	1.5
3	3
5	5

Communication plug connector / MJ*

Nil	None
S	Straight type
T	T branch type

Number of axis, and type of power supply / C9 *

1	1 axis, DC24V
---	---------------

* When "Without controller/drivers" selected for controller/driver type, I/O cable, Communication plug connector, Number of axis, and type of power supply could not be selected.

⑩ Controller /Driver option

6* 1* A* MJ	
Nil	Screw mounting type
D	DIN rail mounting type *
C9	
7	Screw mounting type
8	DIN rail mounting type *

* DIN rail is not included, Order it separately.

⚠ Caution

The actuator body and controller are sold as a package.

If when only the actuator is purchased separately, confirm that the combination of the controller, which you have and the actuator is compatible. / See 6.3 ⚠ Caution(1) on p.36

<Be sure to check the following before use.>

- (1) Check that actuator label for model number.
This matches the controller.
- (2) Check Parallel I/O configuration matches (NPN or PNP).

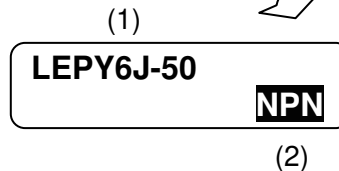

2.3 Construction

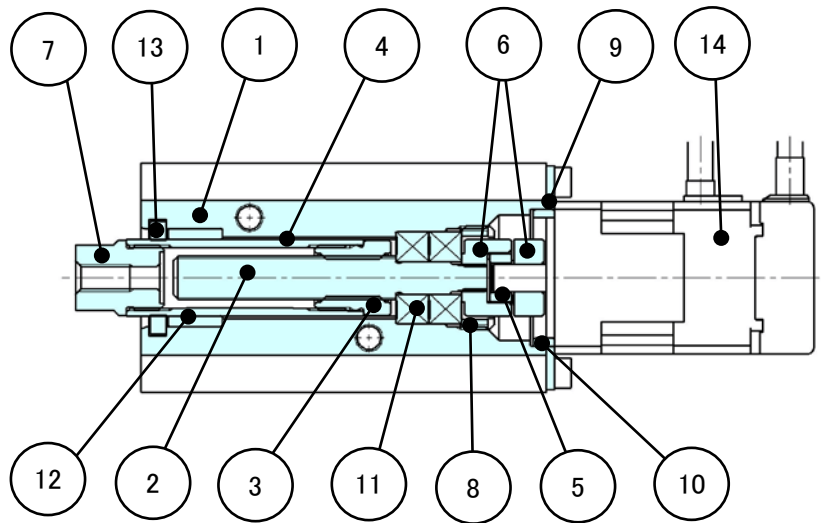

Parts list

No.	Part	Material	Remarks
1	Body	Aluminum alloy	Anodized
2	Screw shaft	Stainless steel	Heat treated Specially treated
3	Screw nut	Stainless steel	Heat treated Specially treated
4	Rod	Stainless steel	
5	Sleeve	NBR	
6	Hub	Aluminum alloy	
7	Socket	Free cutting carbon steels	Nickel plated
8	Bearing holder	Size6 : Aluminum alloy Size10 : Carbon steel	
9	Motor Plate	Aluminum alloy	Anodized
10	Guide ring	Aluminum alloy	Size10 only
11	Bearing	-	
12	Bushing	Oil impregnated sintered copper alloy	
13	Soft wiper	-	
14	Step motor (Servo / 24VDC)	-	

3. Electric Miniature Actuator / Slide table type

3.1 Specification

Model		LEPS 6		LEPS 10			
Actuator specification	Stroke [mm]	25, 50					
	Screw lead [mm]	4	8	5	10		
	Pushing force [N] Note1) Note6)	Basic	14 ~ 20	7 ~ 10	25 ~ 50	12.5 ~ 25	
		Compact	-	-	24 ~ 40	12 ~ 20	
	Work load [kg] Note2) Note3) Note6)	Horizontal	Basic	1	0.75	2	1.5
			Compact	-	-	2	1.5
		Vertical	Basic	0.5	0.25	1.5	1
			Compact	-	-	1.5	1
	Speed [mm/s] Note3) Note6)	Horizontal	Basic	10 to 150	20 to 300 ^{Note4)}	10 to 200	20 to 350 ^{Note4)}
			Compact	-	-	10 to 200	20 to 350 ^{Note4)}
		Vertical	Basic	10 to 150	20 to 300	10 to 150	20 to 300 ^{Note4)}
			Compact	-	-	10 to 150	20 to 300 ^{Note4)}
	Pushing speed [mm/s] ^{Note5)}		10	20	10	20	
	Acceleration / Deceleration [mm/s ²]	3000					
	Backlash [mm]	0.2 or less					
	Positioning repeatability [mm]	+/- 0.05					
	Lost motion [mm] ^{Note7)}	0.2 or less					
Impact resistance/vibration Resistance [m/s ²] ^{Note8)}	50 / 20						
Actuation type	Sliding screw						
Guide type	Linear guide						
Max. operating frequency (c.p.m)	60						
Operating temperature range [°C]	5 to 40						
Operating humidity range [%RH]	90 or less (No condensation)						
Electric specification	Motor size	□20		□28			
	Motor type	Step motor (Servo 24VDC)					
	Encoder	Incremental A/B phase (800 pulse/rotation)					
	Rated voltage [VDC]	24 +/- 10%					
	Power consumption [W] Note9)	Basic	12		28		
		Compact	-		22		
	Standby power consumption when operating [W] ^{Note10)}	Basic	11		22		
Compact		-		16			
Max. instantaneous power consumption [W] ^{Note11)}	Basic	22		55			
	Compact	-		45			

Model		LEPS 6		LEPS 10	
Stroke [mm]		25	50	25	50
Weight [kg]	Basic	0.29	0.35	0.56	0.65
	Compact	-	-	0.50	0.59

Note 1) Pushing force accuracy is LEPS6: ±30% (F.S.), LEPS10: ±25%(F.S.).

The pushing force and the duty ratio change according to the set value. Refer to the catalog.

Note 2) The maximum value of the work load for the positioning operation. Refer to the catalog.

Note 3) Speed changes according to the work load. Refer to the catalog.

Note 4) When the stroke is 25 mm, the maximum speed will be 250 mm/sec.

Note 5) Set to the pushing speed when pushing operation.

Note 6) The speed and force may change depending on the cable length, load and mounting conditions. Furthermore, if the cable length exceeds 5 m, then it will decrease by up to 10% for each 5 m. (At 15 m: Reduced by up to 20%)

Note 7) A reference value for correcting an error in reciprocal operation.

Note 8) Impact resistance: No malfunction occurred when the actuator was tested with a drop tester in both an axial direction and a perpendicular direction to the lead screw. (Test was performed with the actuator in the initial state.)

Vibration resistance: No malfunction occurred in a test ranging between 45 to 2000 Hz. Test was performed in both an axial direction and a perpendicular direction to the lead screw.
(Test was performed with the actuator in the initial state.)

Note 9) The power consumption (including the controller) is for when the actuator is operating.

Note 10) The standby power consumption when operating (including the controller) is for when the actuator is stopped in the set position during operation. Except during the pushing operation.

Note 11) The maximum instantaneous power consumption (including the controller) is for when the actuator is operating. This value can be used for the selection of the power supply.

3.2 How to Order

LEPS **10** **K** - **50** - **R16N1**

① ② ③ ④ ⑤ ⑥ ⑦ ⑧ ⑨ ⑩

① Size

6
10

② Motor size

Nil	Basic
L	Compact *

* Size: 10 only

③ Lead screw type(mm)

Symbol	Screw lead	
	LEPS6	LEPS10
K	4	5
J	8	10

④ Stroke(mm)

記号	ストローク
25	25
50	50
75	75

⑤ Motor cable mounting direction

Nil	Top type
R	Entry on the right side
L	Entry on the left side
U	Bottom entry

⑥ Actuator cable*1

Nil	Without cable
S	Standard cables
R	Robotic type cables (Flexible type cables)

*1 The standard cable should be used on fixed parts.

For using on moving parts, select the robotic cable.

*2 Fix the motor cable protruding from the actuator to keep it unmovable. For details about fixing method, refer to Wiring/Cables in the Electric Actuators Precautions.

⑦ Actuator cable length(m)

Nil	Without cable	g	8 *
1	1.5	A	10 *
3	3	B	15 *
5	5	C	20 *

* produced upon receipt of order.

(Only "Robotic type cables" can be selected.)

⑧ Controller /Driver type *

Nil	Without controller	
6N	LECP6	NPN
6P	(Step date input type)	PNP
1N	LECP1	NPN
1P	(Program-less type)	PNP
MJ	LECPMJ (CC-link direct input type)	-
AN	LECPA	NPN
AP	(Pulse input type)	PNP
C9	JXC9 (EtherNet/IP direct input type)	-

* For details about controllers/driver and compatible motors, refer to the compatible controllers/driver below.

⑨ I/O cable length [m] / 6* 1* A* *

Nil	Without cable
1	1.5
3	3
5	5

Communication plug connector / MJ*

Nil	None
S	Straight type
T	T branch type

Number of axis, and type of power supply / C9*

1	1 axis, DC24V
---	---------------

* When "Without controller/drivers" selected for controller/driver type,

I/O cable, Communication plug connector,

Number of axis, and type of power supply could not be selected.

⑩ Controller /Driver option

6* 1* A* MJ

Nil	Screw mounting type
D	DIN rail mounting type *

C9

7	Screw mounting type
8	DIN rail mounting type *

* DIN rail is not included, Order it separately.

⚠ Caution

The actuator body and controller are sold as a package.

If when only the actuator is purchased separately, confirm that the combination of the controller, which you have and the actuator is compatible. / See 6.3 ⚠ Caution(1) on p.36

<Be sure to check the following before use.>

- (1) Check that actuator label for model number.
This matches the controller.
- (2) Check Parallel I/O configuration matches (NPN or PNP).

LEPS6J-50

NPN

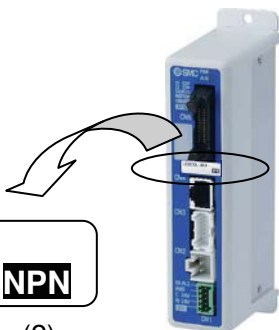

(1)

(2)

3.3 Construction

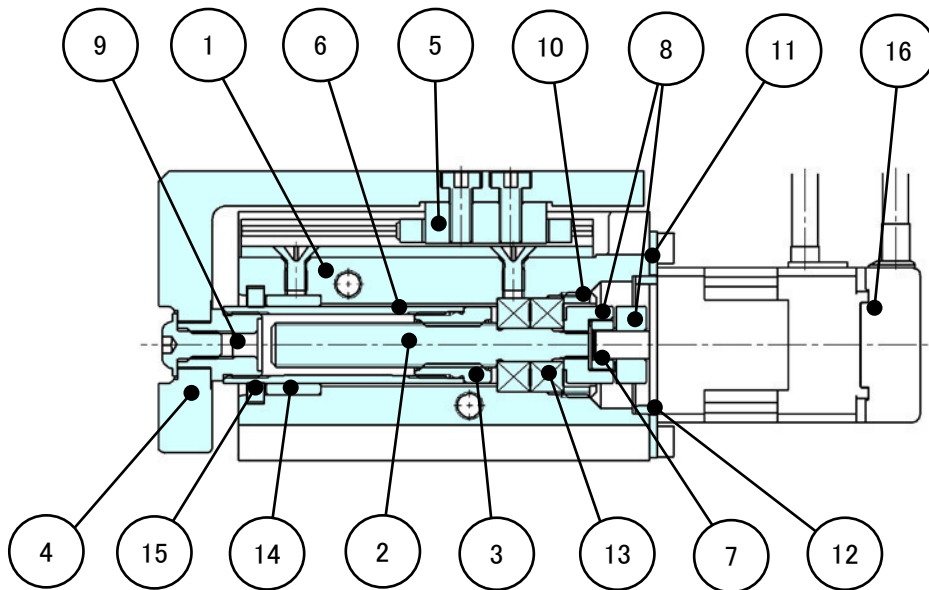

Parts list

No.	Part	Material	Remarks
1	Body	Aluminum alloy	Anodized
2	Screw shaft	Stainless steel	Heat treated Specially treated
3	Screw nut	Stainless steel	Heat treated Specially treated
4	Table	Aluminum alloy	Anodized
5	Linear guide	-	
6	Rod	Stainless steel	
7	Sleeve	NBR	
8	Hub	Aluminum alloy	
9	Socket	Free cutting carbon steels	Nickel plated
10	Bearing holder	Size6 : Aluminum alloy Size10 : Carbon steel	
11	Motor Plate	Aluminum alloy	Anodized
12	Guide ring	Aluminum alloy	Size10 only
13	Bearing	-	
14	Bushing	Oil impregnated sintered copper alloy	
15	Soft wiper	-	
16	Step motor (Servo / 24VDC)	-	

4. Product Outline

4.1 System construction

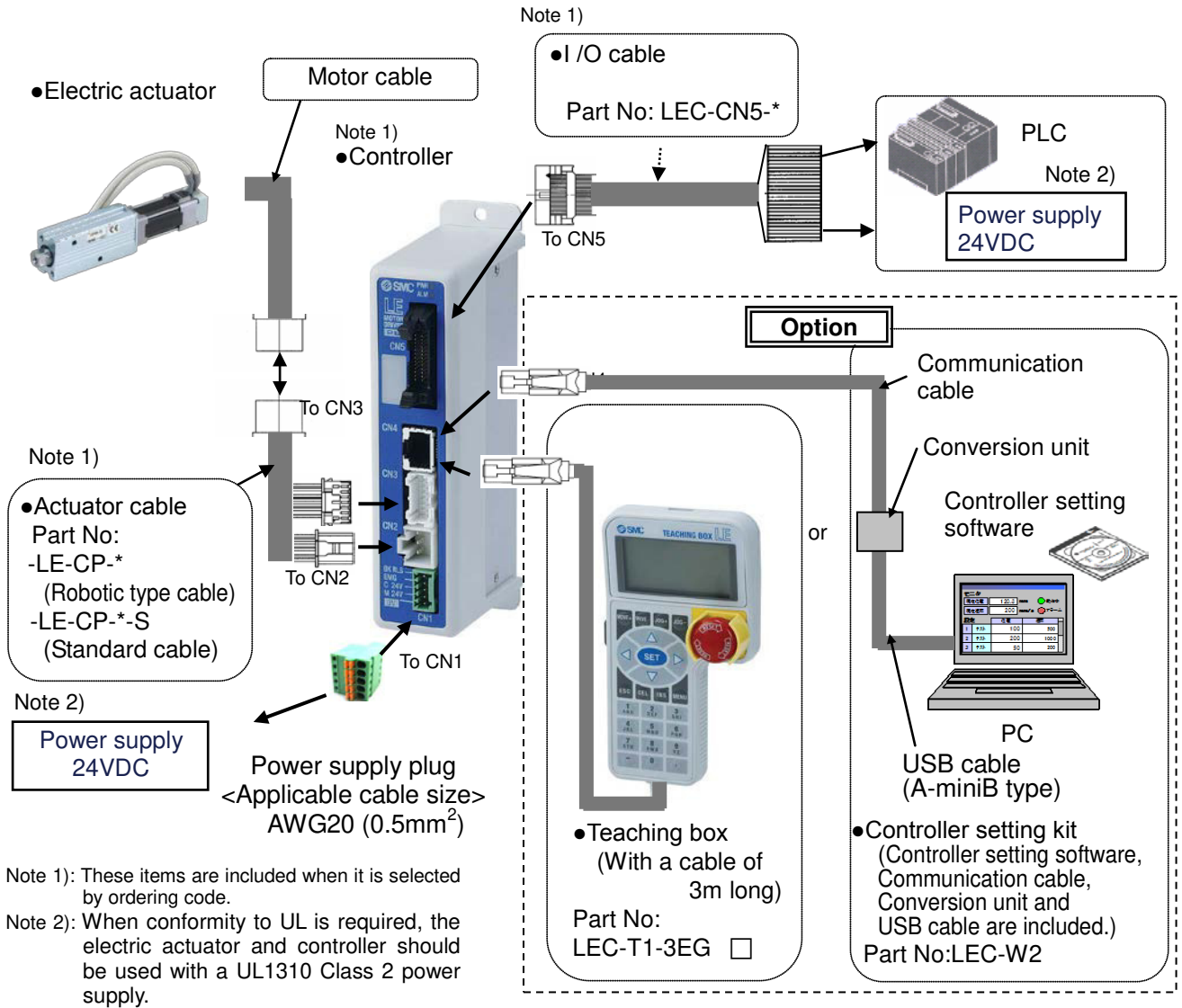

Warning

Refer to the operation manual of the LEC (controller) for detailed wiring.
/See 5 Wiring of cables on p.33.

Communication cable is to be connected to PC by USB cable through conversion unit.

Do not connect the teaching box directly to the PC.

Use only specified cables otherwise there maybe fire risk and damage.

The actuator body and controller are sold as a package.

If when only the actuator is purchased separately, confirm that the combination of the controller, which you have and the actuator is compatible.

/ See 6.3 Caution (1) on p. 36

<Be sure to check the following before use.>

(1) Check that actuator label for model number.
This matches the controller.

(2) Check Parallel I/O configuration matches (NPN or PNP).

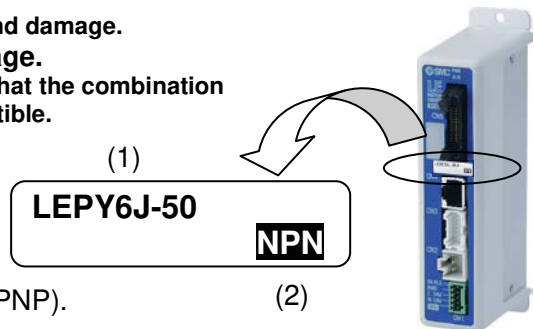

4.2 Setting Function

Refer to the operation manual of the controller (LEC series) for the detail of the setting function.

Easy Mode for simple setting

>Select “Easy mode” for instant operation

Controller setting software

- Setting and operation, such as the step data setting, test drive and JOG / fixed-distance moving, can be performed on the same page.

Speed setting of JOG / fixed distance

JOG moving

Start testing

Positioning data setting

Fixed distance moving

No.	Move M	Speed mm/s	Position mm	Pushing F %	TriggLY %	In pos mm
0	Absolute	50	24.00	0	0	0.50
1	Absolute	50	12.00	40	40	24.00
2						
3						
4						
5						
6						
7						
8						
9						

Teaching box

- Setting and operation by the simple screen without scrolling.
- Select function by the iconized menu at the first page.
- Step data setting and monitoring at the second page.

1st screen

2nd screen

Data	Axis 1
Step No.	0
Posn	123.45mm
speed	100mm/s

It can be registered by “SET” after entering the values.

Example of setting the step data

1st screen

2nd screen

Monitor	Axis 1
Step No.	1
Posn	12.34mm
speed	50mm/s

Operation status can be checked

Example of checking the operation status

Normal mode for the detailed setting

> Select “Normal mode” if the detailed setting are necessary.

- Step data can be set in detail.
- Parameters can be set.
- Signals and terminal condition can be monitored.
- JOG and fixed distance movement, return to origin position, test operation and testing of compulsory output can be done.

Controller setting soft ware

- Every function, step data, parameter, monitor and teaching are indicated in a different window.

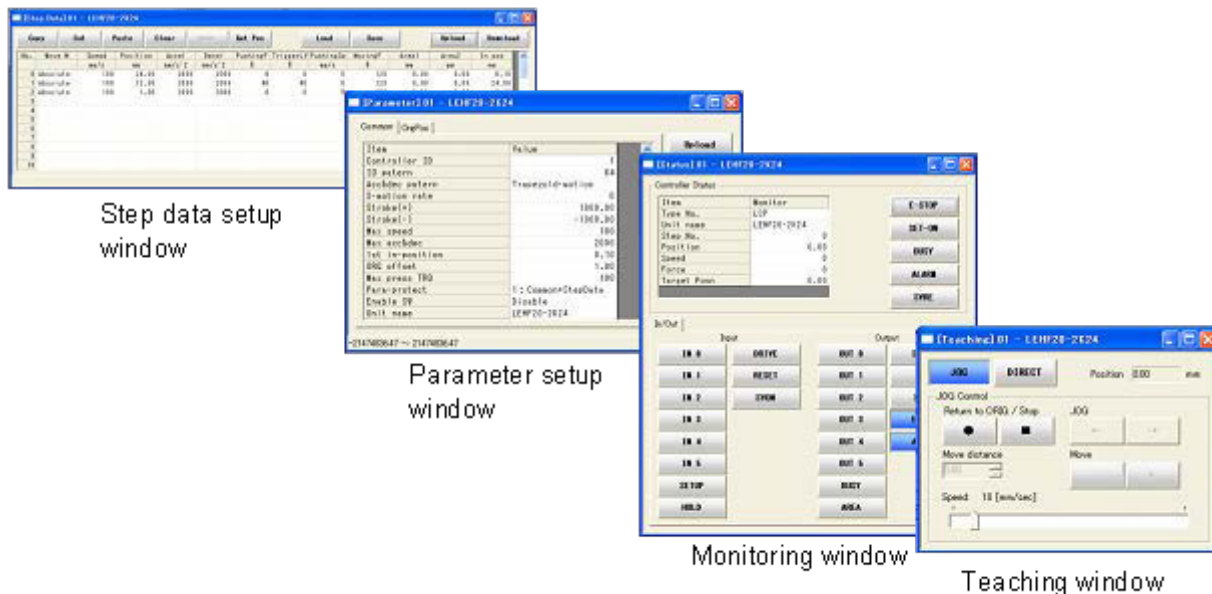

Teaching box

- The data in the controller can be saved / forwarded in this teaching box.
- Continuous test operation can be made after specifying five step data.

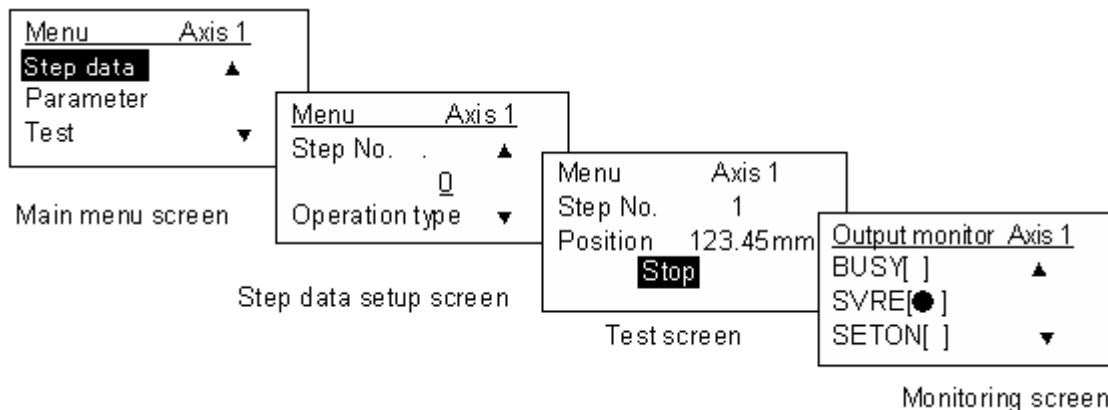

Controlled items

PC: Controller setting software TB: Teaching box
 ○: Available function ×: Not available function

Function		Content	Easy mode		Normal mode
			PC	TB	PC/TB
Step data (Except)	Movement method	Can be selected of absolute / relative position move	○	×	○
	Speed	Can be set in units of 1mm/s.	○	○	○
	Position	Can be set in units of 0.01mm.	○	○	○
	Acceleration Deceleration	Can be set in units of 1mm/s ² .	○	○	○
	Pushing force	Can be set in units of 1%. / In case of positioning operation: Set to 0%.	○	○	○
	Trigger LV	Trigger LV of target pushing force when pushing operation: Can be set in units of 1%.	○	×	○
	Pushing speed	Can be set in units of 1mm/s.	○	×	○
	Moving force	150% (Not changeable)	○	×	○
	Area output	Can be set in units of 0.01mm.	○	×	○
	In position	During positioning operation: Width to the target position. It should be set to 0.5 or more. During pushing operation: How much it moves during pushing.	○	×	○
Parameter (Excerpt)	Stroke(+)	+ side limit of position. (Can be set in units of 0.01mm)	×	×	○
	Stroke(-)	- side limit of position. (Can be set in units of 0.01mm).	×	×	○
	ORIG direction	Direction of the return to the original position can be set	×	×	○
	ORIG speed	Speed when returning to the original position can be set.	×	×	○
	ORIG ACC	Acceleration when returning to origin can be set.	×	×	○
Test	JOG	It can make continuous operation at the set speed while the switch is being pressed	○	○	○
	MOVE	It can make test operation at the set distance and speed from the current position when the switch is pressed.	○	×	○
	Return to ORIG	Test of return to origin can be done.	○	○	○
	Test drive	The operation of the specified step data can be tested.	○	○	○ (Continuous operation)
	Force output	ON/OFF of the output terminal can be tested.	×	×	○
Monitor	DRV mon	Current position, current speed, current force and the specified step data No. can be monitored.	○	○	○
	In/Out mon	Current ON/OFF status of the input and output terminal can be monitored.	×	×	○
ALM	Status	The alarm currently being generated can be confirmed, and be reset.	○	○	○
	ALM Log record	The alarm generated in the past can be confirmed.	×	×	○
File	Save - Load	The step data and parameter of the objective controller can be saved, forwarded and deleted.	×	×	○
Other	Language	Language can be changed to Japanese / English.	○ *3	○ *2	○ *2 *3

*1 Every parameter is set to the recommended condition before shipment from the factory. Only change the setting of the items which require adjustment.

*2 Teaching box: In the Normal mode the teaching box can be set to work in English or Japanese.

*3 Controller setting software: Can be installed by selecting English version or Japanese version.

4.3 Step data setting method

Refer to the operation manual of the controller (LEC series) for details.

This operation manual specifies the electric actuator, if an actuator other than the electric actuator is used, refer to the operation manual of each type of actuator and controller (LEC series) regarding the description of step data.

Caution

The actuator body and controller are sold as a package.

If when only the actuator is purchased separately, confirm that the combination of the controller, which you have and the actuator is compatible. / P.36 Notes 6.3  Caution(1)

<Be sure to check the following before use.>

(1) Check that actuator label for model number.

This matches the controller.

(2) Check Parallel I/O configuration matches (NPN or PNP).

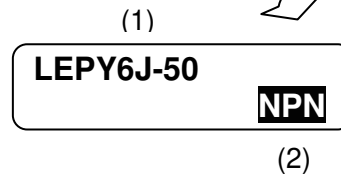

Positioning operation

In the positioning operation, the electric actuator transfers to and stops at the target position. The following image shows the set items and operation.

<Confirmation of reaching the target position during the positioning operation>

When the electric actuator reaches the range of the target position, the "target position reaching signal" **【INP】** (in position) is outputted.

When the rod of actuator enters the range of **【in position】**, the INP output signal turns on.

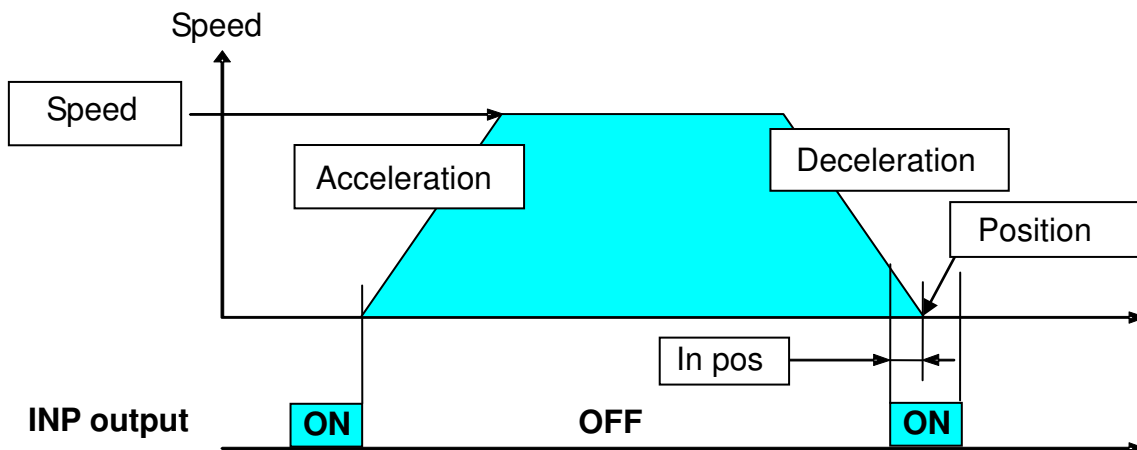

Caution

Please use it by "Pushing operation" when you make it hold.

The product may be damaged by the impact when using it in "Positioning operation".

/ See 7.3  Caution(2) on p.42

<Items and set values in positioning operation>

Step No. 1: Positioning operation

No.	Move M	Speed mm/s	Position mm	Accel mm/s ²	Decel mm/s ²	PushingF %	TriggerLV %	PushingSp mm/s	MovingF %	Area1 mm	Area2 mm	In_pos mm
0	Absolute	100	15.00	3000	3000	70	70	20	150	20.00	22.00	10.00
1	Absolute	100	0.00	3000	3000	0	0	20	150	0.00	2.00	0.50

[] Need to be set - [] Need to be adjusted as required.

[] Not used. Items don't need to be changed in positioning operation.

- a** < Movement MOD > When the absolute position is required, set Absolute
When the relative position is required, set Relative
→ Absolute: Distance from the origin position. / General setting method.
Relative: Feed from the current position. / This is used when simplified data.
- b** < Speed > Transfer speed to the target position.
- c** < Position > Target position.
- d** < Acceleration > The parameter which defines how rapidly the actuator reaches the speed set in **b**.
The higher the set value, the faster it reaches the speed set in **b**.
- e** < Deceleration > The parameter which defines how rapidly the actuator comes to stop.
The higher the set value, the quicker it stops.
- f** < Pushing force > Set **0**.
(If values other than 0 set the operation will be changed to the pushing operation.)
- g** < Trigger LV > For pushing operation only. Not applicable for this product.
- h** < Pushing speed > For pushing operation only. Not applicable for this product.
- i** < Moving force > Max. Force at the positioning operation.
The force is automatically adjusted corresponding to the load.
Initial value: Set to [150%] / See 7.3 **⚠ Caution(4)** on p.42
- j** < Area1, Area2 > This is the condition that turns on the AREA output signal.
The setting condition should be **Area 1 < Area 2**.
It is possible to set at relative operation.
The position will be Absolute (position from the origin).
Example) In case of Step no.1
[AREA] output signal is outputted between Area 1:0 and Area 2:2.
- k** < In position > This is the condition that turns on the INP (in position) output signal.
→ When the electric actuator reaches the range of the target position, the INP output signal is output.
When the electric actuator enters the range of [in position], the INP output signal turns on.
When it is necessary to output the target position reaching signal earlier, make the value larger.
Note) Set the value more than [0.50].
Example) In case of Step no.1
Position: 0 + In position: 0.5 = [INP] is outputted from the value of 0.5.

Pushing operation

The rod moves to the target position and holds a work piece with the set pushing force. The figure shows setting items and operation. The setting items and values are described below.

< Confirmation of reaching the target value during the pushing operation >

The "target position reaching signal" 【INP】 (in position) is generated when the target pushing force (Trigger LV) is achieved.

Also, if the actual pushing force exceeds the Trigger LV, the INP signal is turned on.

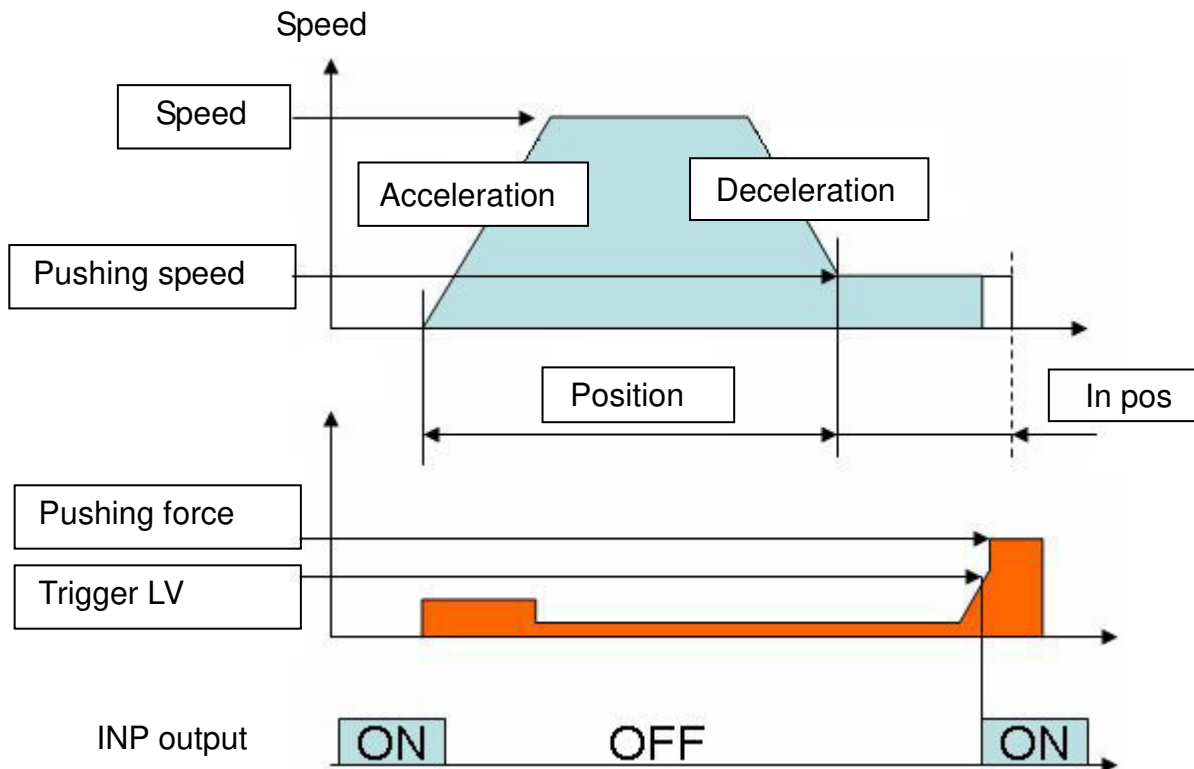

Caution

Please use it by "Pushing operation" when you make it hold.

The product may be damaged by the impact when using it in "Positioning operation".







/ See 7.3  Caution(2) on p.42

<Items and setting values of pushing operation>

Step no. 0: Pushing operation

	a	b	c	d	e	f	g	h	i	j	k	
No.	Move M	Speed	Position	Accel	Decel	PushingF	TriggerLV	PushingSp	MovingF	Area1	Area2	In pos
		mm/s	mm	mm/s ²	mm/s ²	%	%	mm/s	%	mm	mm	mm
0	Absolute	100	15.00	3000	3000	70	70	20	150	20.00	22.00	10.00
1	Absolute	100	0.00	3000	3000	0	0	20	150	0.00	2.00	0.50

[] Need to be set - [] Need to be adjusted as required.

- a** < Movement MOD > When the absolute position is required, set Absolute.
When the relative position is required, set Relative.
Absolute: Distance from the origin position. / General setting method.
Relative: Feed from the current position. / This is used when simplified data.
- b** < Speed > Transfer speed to the target position.
- c** < Position > Target position.
The pushing starting position is set forward by 2mm or more of the pushing object.
- d** < Acceleration > The parameter which defines how rapidly the actuator reaches the speed set in **b**.
The higher the set value, the faster it reaches the speed set in **b**.
→
- e** < Deceleration > The parameter which defines how rapidly the actuator comes to stops.
The higher the set value, the quicker it stops.
- f** < Pushing force > Pushing force ratio is defined.
/See 7.3  Caution(12) on p.43 and  Caution(14) on p.44
- g** < Trigger LV > The condition at which INP output signal is turned on.
Set it at the value equivalent to the pushing force or less.
/See 7.3  Caution(12) on p.43
The INP output signal is given when the target force (Trigger LV) is achieved.
The INP output signal is turned on when the generated force exceeds the value.
- h** < Pushing speed > The pushing speed
Set the speed in the following range. If the speed is too high, the actuator or work piece can be damaged by impact.
/See 7.3  Caution(2) on p.42 and  Caution(12) on p.43
- i** < Moving force > The upper force limit for the pushing operation starting position
The force is automatically adjusted corresponding to the load.
Initial value: Set to [150%] /See 7.2  Caution(4) on p.42
- j** < Area1, Area2 > This is the condition that turns on the AREA output signal.
The setting condition should be **Area 1 < Area 2**
It is possible to set at Relative operation.
The position will be Absolute (position from the origin).
- k** < In position > The transfer distance (relative value) when pressing
If the transferred distance exceeds the setting, it stops even if it is not pressing.
If the transfer distance is exceeded, the INP output signal will not be turned on.
(incomplete pushing)
Example) In case of Step no.0
Position: 15 + In Position: 10 = 25
(The position where the incomplete pressing is detected.)

Example of step data entry (1)

< Positioning operation - 【INP】output signal, 【AREA】output signal >

No.	Move M	Speed mm/s	Position mm	Accel mm/s ²	Decel mm/s ²	PushingF %	TriggerLV %	PushingSp mm/s	MovingF %	Area1 mm	Area2 mm	In pos mm
0	Absolute	100	20.00	3000	3000	0	0	0	100	16.00	18.00	0.50

-Step data no.0 : Positioning operation (It moves from Position:0[mm] to Position:20[mm])

Condition 1) The 【AREA】output signal is not used.

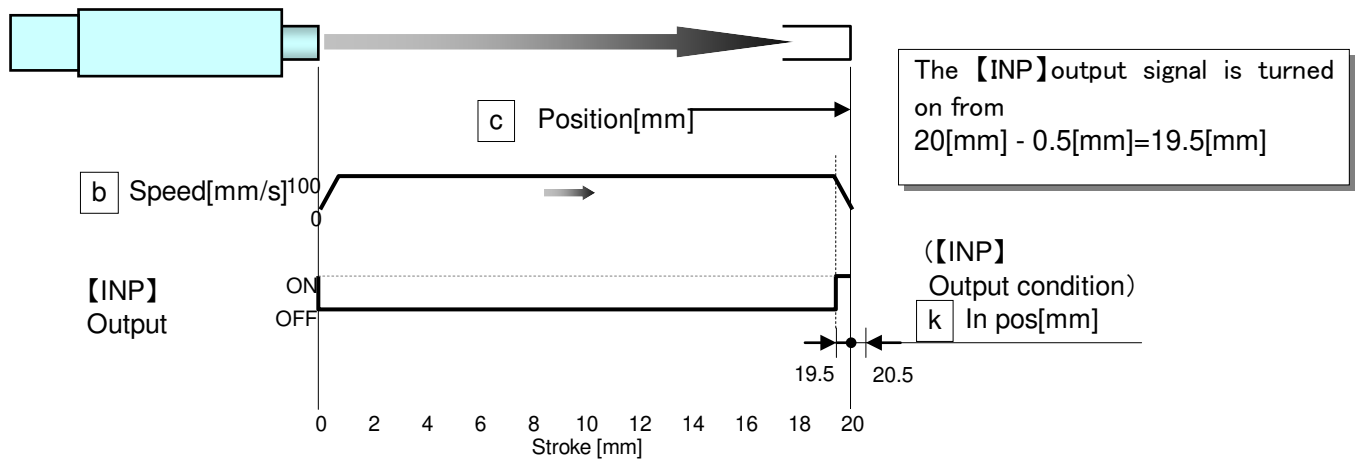

Condition 2) The 【AREA】output signal is used.

*The 【AREA】output signal is a signal output when the rod traverses through a certain range (The step data: **Area 2** from **Area 1**).

This feature is useful when an output to check the rod position at intermediate stroke is required.

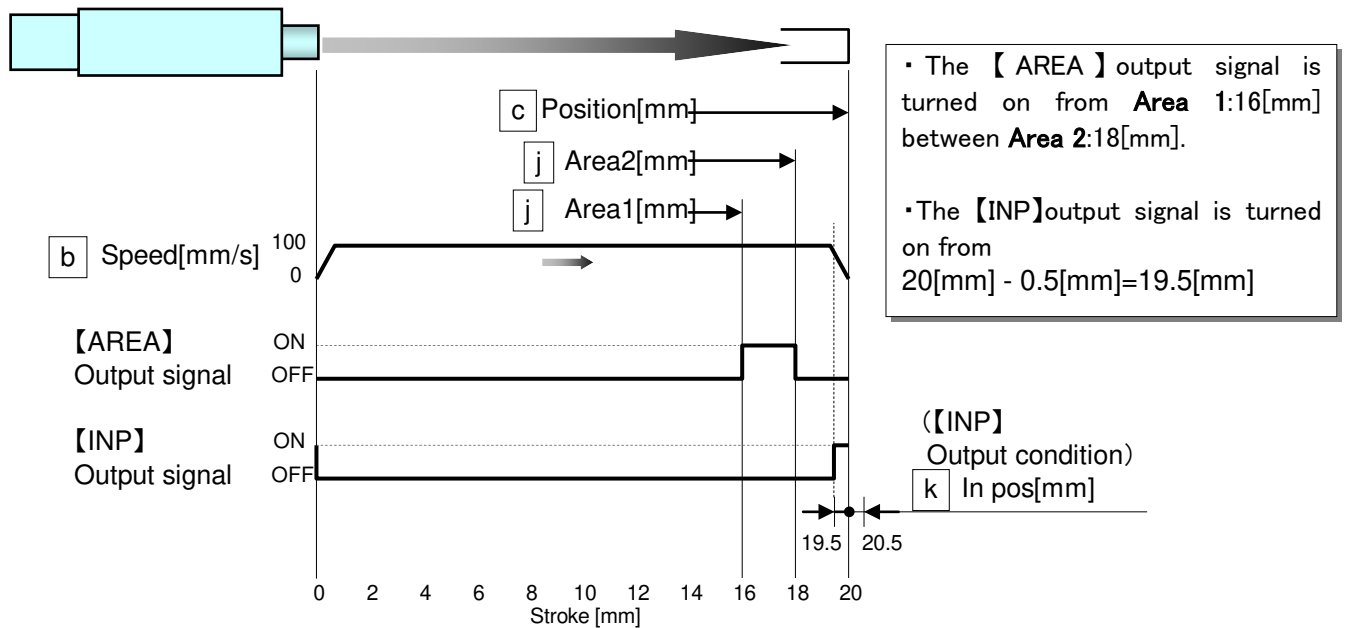

Example of step data entry (2)

< Pushing operation - 【INP】output signal, 【AREA】output signal >

No.	Move M	Speed mm/s	Position mm	Accel mm/s ²	Decel mm/s ²	PushingF %	TriggerLV %	PushingSp mm/s	MovingF %	Area1 mm	Area2 mm	In pos mm
0	ABS	100	16.00	3000	3000	85	85	20	150	14.00	20.00	5.00

-Step data no.0 : Positioning operation. (It moves to End limit after it moves from 0mm to 16mm.)

Condition 1) The 【AREA】output signal is not used.

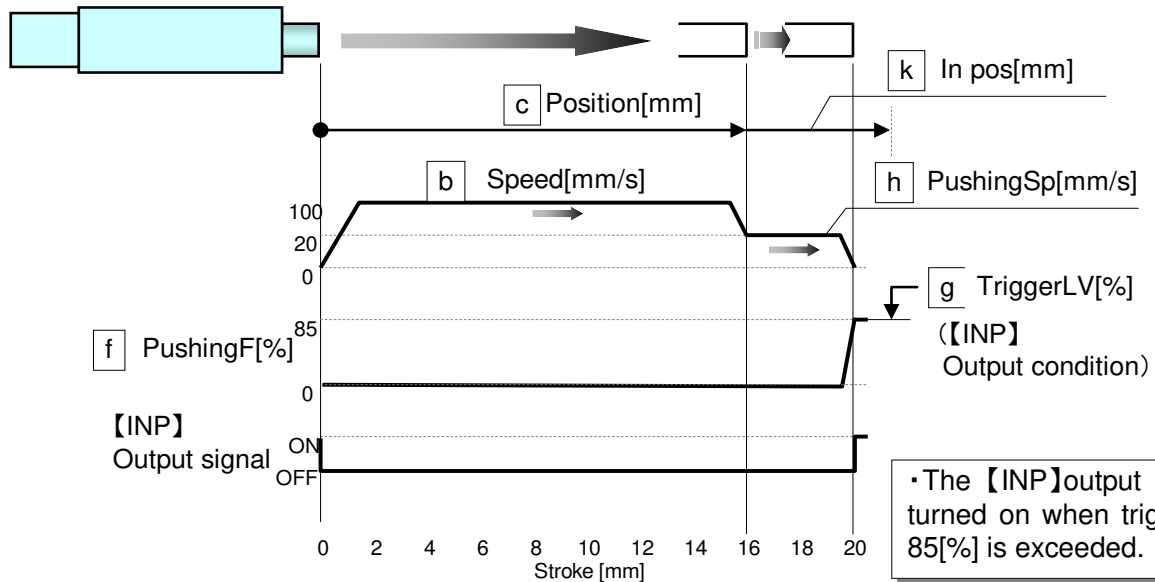

Condition 2) The 【AREA】output signal is used.

* The 【AREA】output signal is a signal output when the rod traverses through a certain range (The step data: **Area 2** from **Area 1**).

This feature is useful when an output to check the rod position at intermediate stroke is required.

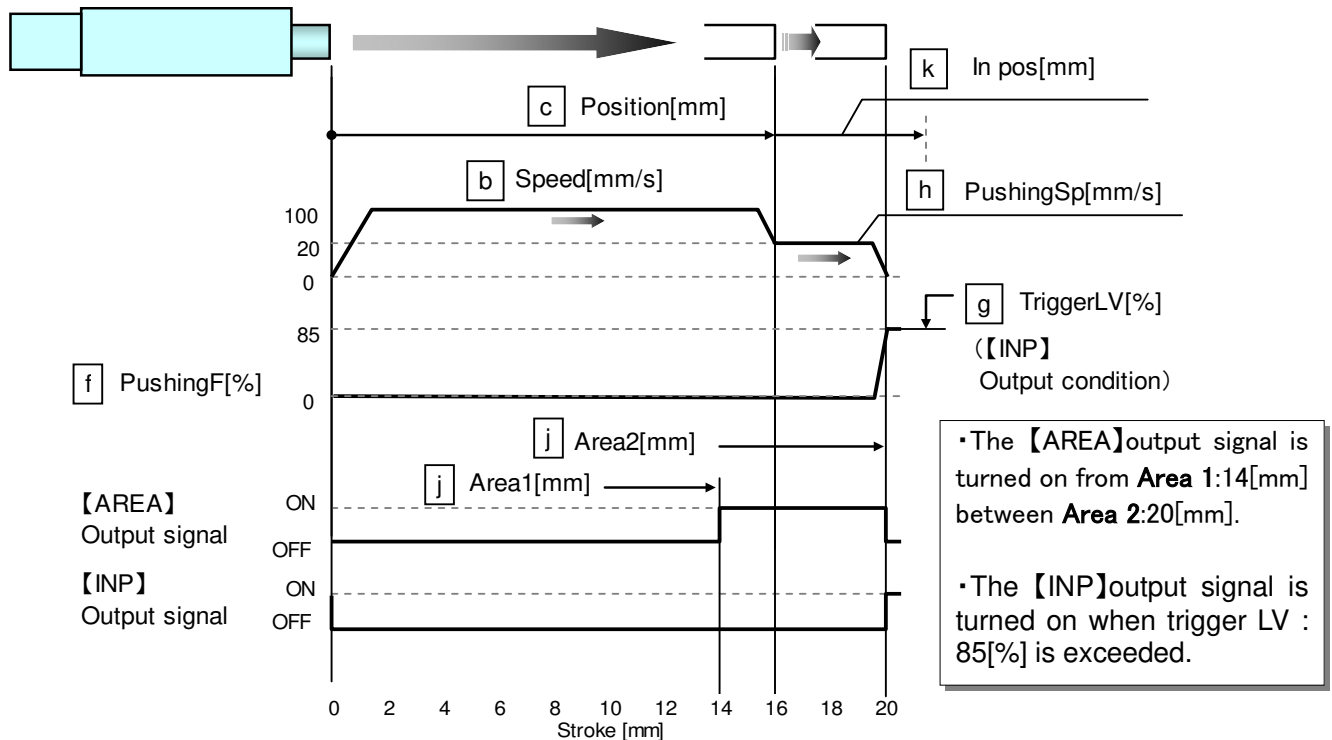

Example of step data entry (3)

< Positioning operation - Relative >

	a	b	c	d	e	f	g	h	i	j	k	
No.	Move M	Speed mm/s	Position mm	Accel mm/s ²	Decel mm/s ²	PushingF %	TriggerLV %	PushingSp mm/s	MovingF %	Area1 mm	Area2 mm	In pos mm
0	Relative	100	5.00	3000	3000	0	0	0	150	20.00	25.00	0.50
1	Relative	100	-5.00	3000	3000	0	0	0	150	5.00	10.00	0.50

*Absolute: Distance from the origin position.

*Relative: Feed from the current position.

Condition 1) 15mm position → **Step no.0** → **Step no.0** (Move M: Relative)

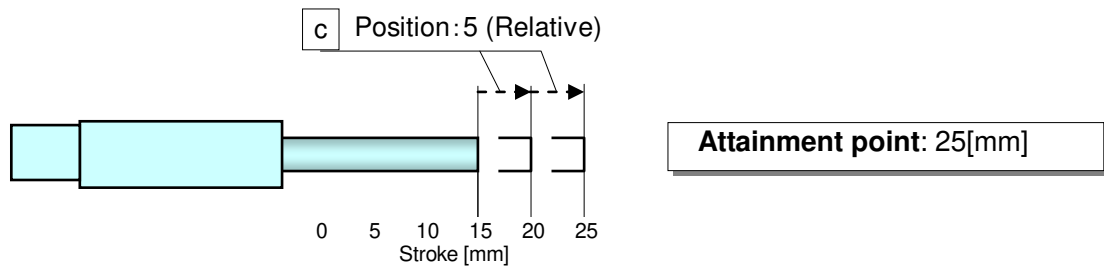

Condition 2) 15mm position → **Step no.1** → **Step no.1** (Move M: Relative)

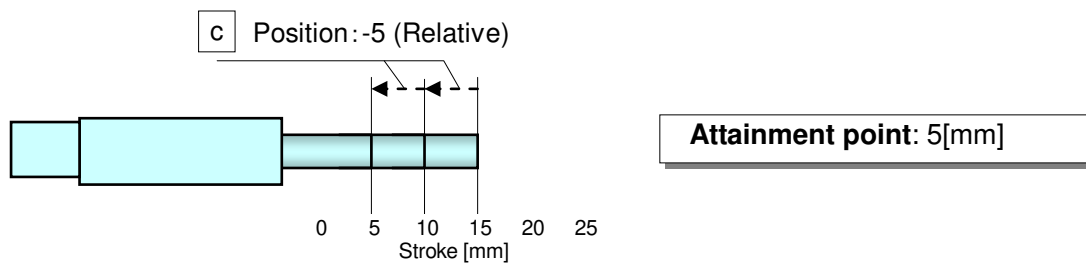

Example of step data entry (4)

< Pushing operation - In position >

No.	Move M	Speed mm/s	Position mm	Accel mm/s ²	Decel mm/s ²	PushingF %	TriggerLV %	PushingSp mm/s	MovingF %	Area1 mm	Area2 mm	In pos mm
0	Absolute	100	10.00	3000	3000	85	85	20	150	12.00	17.00	10.00

•Step data no.0 : Pushing operation ("Pushing operation" is done during 10mm after it moves from 0mm to 10mm.)

Condition 1) Length to work < In position

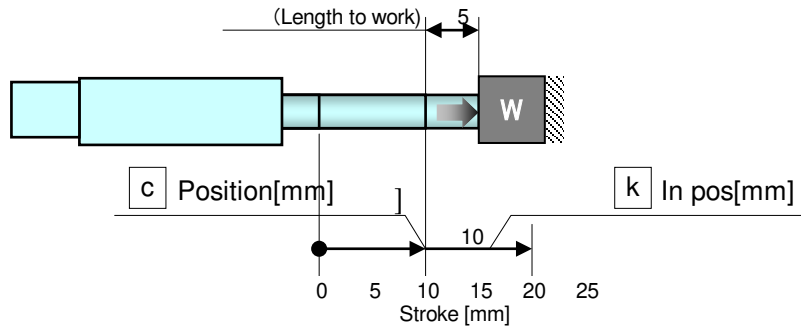

【INP】Output condition

- k In pos \geq Length to work
- Actual force \geq g TriggerLV



The 【INP】 output signal is turned on

Condition 2) Length to work > In position

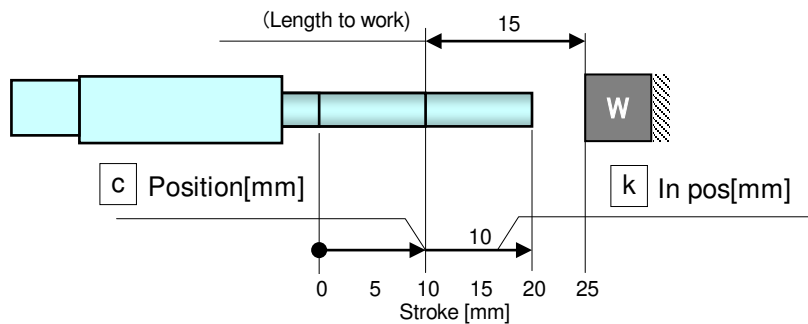

【INP】Output condition

- k In pos < Length to work
- Actual force < g TriggerLV

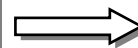

The 【INP】 output signal is not turned on
The 【BUSY】 output signal is turned off

Example of step data entry (4)

< Pushing operation – Driving starting position >

The pushing action is different and dependent upon the starting position and direction.
Confirm the position where the pushing operation starts.

No.	Move M	Speed mm/s	Position mm	Accel mm/s ²	Decel mm/s ²	PushingF %	TriggerLV %	PushingSp mm/s	MovingF %	Area1 mm	Area2 mm	In pos mm
0	Absolute	100	0.00	3000	3000	0	0	0	150	15.00	20.00	0.50
1	Absolute	100	25.00	3000	3000	0	0	0	150	15.00	20.00	0.50
2	Absolute	100	15.00	3000	3000	85	85	20	150	15.00	20.00	5.00

Condition 1) In case the pushing operation is **Step no.0** to **Step no.2**.

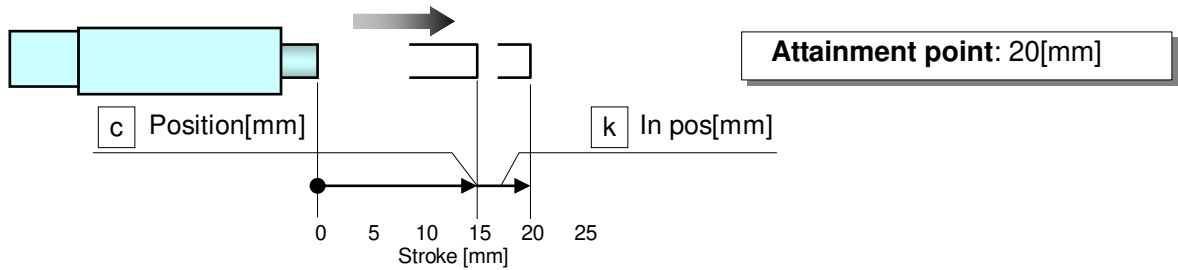

Condition 2) In case the pushing operation is **Step no.1** to **Step no.2**.

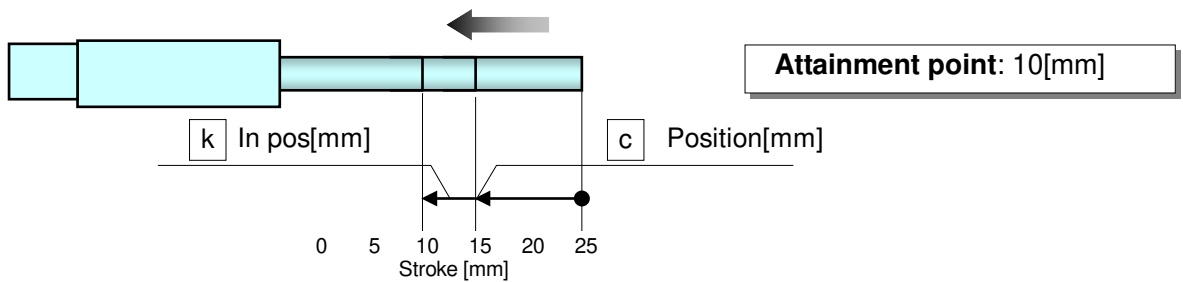

Operating procedure and input / output signals for each operation

The input / output signal and the operation description for operating this electric actuator are as follows.

1) Signals along with the operation procedures

In case the operation order is

1. Supply power to the motor → 2. Return to origin → 3. Step no. 1 → 4. Step no. 2 → 5. Cutting power to the motor

Procedure	Input signal	Output signal to the input signal	Operation description
1	SVON(Servo on)[●]	SVRE(Servo ready) [●]	Power is supplied to the motor, and detection of the magnetic pole position. =>Complete.
2	SETUP [●]	SETON [●] INP(IN position)[●]	Return to the origin. =>Complete.
3	IN0 [●] IN1 [] IN2 [] IN3 [] IN4 [] IN5 [] ↓ DRIVE [●] => [] note.3)5)	OUT0 [●] OUT1 [] OUT2 [] OUT3 [] OUT4 [] OUT5 [] } note.3)4) ↓ After reaching of target position, INP [●] After stopping motion, BUSY []	Step no. 1 is selected, and the operation starts. =>Completion.
4	IN0 [] IN1 [●] IN2 [] IN3 [] IN4 [] IN5 [] ↓ DRIVE [●] => [] note.3)5)	OUT0 [] OUT1 [●] OUT2 [] OUT3 [] OUT4 [] OUT5 [] } note.3)4) ↓ After reaching of target position, INP [●] After stopping motion, BUSY []	Select the step no. 2, and the operation starts. =>Complete.
5	SVON []	SVRE [] SETON [●] note.2) INP [●]	Power to the motor is cut.

Note 1) [●] means ON, [] means OFF.

Note 2) The origin has been recognized when the operation is repeated, so it can operate without the procedure item 2.

Note 3) The "OUT*" signals are reset during the rising edge of the Drive signal. The "OUT*" signal which follows the "IN*" signal are outputted at the falling edge of the "DRIVE" signal.

Note 4) When the alarm is generated, the alarm group is displayed.
Please confirm controller (LEC series) manual for a detailed content of the alarm.

Note 5) Leave an interval of 15ms (the recommendation is 30ms) or more between input signals and maintain the state of the signal for 15ms (the recommendation is 30ms) or more, because PLC processing delays and controller scanning delays can occur.

2) Signals when Stopped: In the event when “EMG” is used

/ See 6.1 Caution (9) on p.34

The operating sequence is **1. "Stop"** → **2. Release the "Stop"**

Procedure	Input signal	Output signal to the input signal	Operation description
1	EMG:Not energizing (TB / Stop switch:Locking)	*ESTOP [] SVRE [] SETON [•]	Power to the motor is cut by the "Stop" command regardless of whether it is operating or stopping.
2	EMG:Energizing (TB / Stop switch:Releasing)	* ESTOP [•] SVRE [•] SETON [•] Note 2)	The stop is released.

Note 1) [•] means ON, [] means OFF. *means negative logic

Note 2) SETON signal does not change after releasing the "STOP"

Note 3) If the stop is input from the EMG or RESET terminal or the stop-switch on the connected Teaching Box during pushing operation, the actuator stop.
("Busy" signal turns OFF) And if the actuator stop within the range of "Position" ± "In pos" defined in step data, output signal "INP" turns ON.

4.4 Parameter setting method

Initial setting for the basic parameters

Refer to the controller's (LEC series) operation manual for detail.

As the "basic parameter" is unique data of each actuator, if an actuator other than the "electric actuator / rod type" is used, refer to the operation manual of each actuator and the controller's (LEC series)

Description (Extract)	Initial input value	Input range
Controller ID	1	1 to 64 Note 1)
IO pattern	1 : 64	-
Acceleration / deceleration pattern	1: Trapezoid - motion	-
S-motion ratio	0	-
Stroke (+)	1000.00	-
Stroke (-)	-1000.00	-
Maximum speed	Max. speed of each product	Step data input limit: Max. speed of each product
Maximum acceleration / deceleration	3000	to 3000
Default In positioning	0.5	-
Origin offset	0.00	Note 2)
Maximum pushing force	LEP□ 6 (Basic) : 100	70 to 100
	LEP □ 10 (Basic) : 100	50 to 100
	LEP□ 10L (Compact) : 100	60 to 100
Parameter protect	1: Common + StepData	Changeable parameter 1: Common + StepData, 2: Common
Enable switch	2: Disable	Select 1:Enable or 2:Disable when using a teaching box
Model name	Part no. of each product	Only the English characters and numbers are changeable.
W-area output end 1	0.00	-
W-area output end 2	0.00	-
Origin correction data	0.00	-

Note1) Become effective after restarting the controller.

Note 2)The origin offset is used for the "return to origin". / See 2) Origin offset on p.31

<Return to origin>

Before the positioning and pushing operation, "return to origin" is necessary to establish the origin. The current position value of the actuator increases if the rod extend (move in the CW direction). (The rod moving direction to be increased cannot be changed.)

1) Flow of return to origin

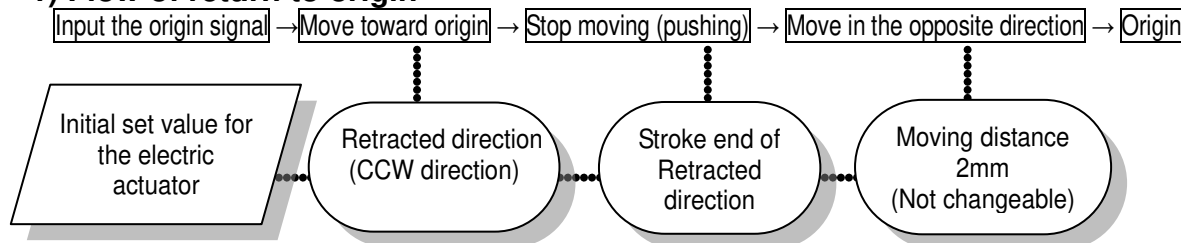

2) Origin offset

The origin offset means the value of the origin. ("Origin offset"=origin)

When the parameter "Origin offset" is changed, the value of "Stroke(+)", "Stroke(-)" of basic parameter should be checked again.

Initial input value: "Origin offset"=0

Move in the opposite direction (Moving distance 1mm / Not changeable) by the return to origin becomes "origin =0".

a) Origin direction: CCW

Example) Actuator stroke 25mm

"Origin offset"=0 (Initial input value)

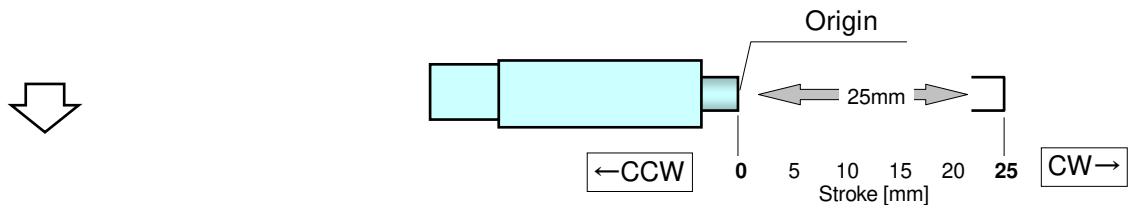

"Origin offset"=10

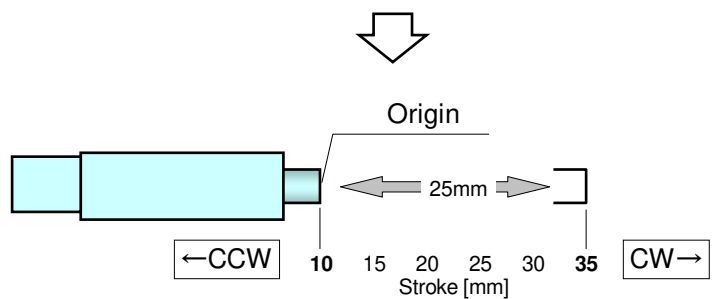

b) Origin direction: CW

Example) Actuator stroke 25mm

"Origin offset"=0 (Initial input value)

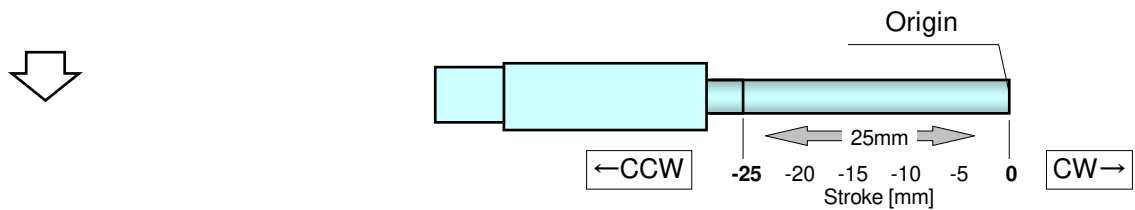

"Origin offset"=10

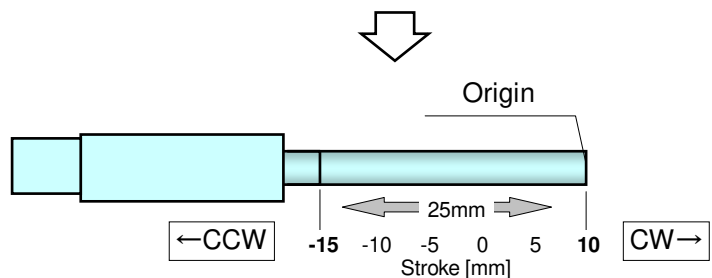

"Origin offset"=-10

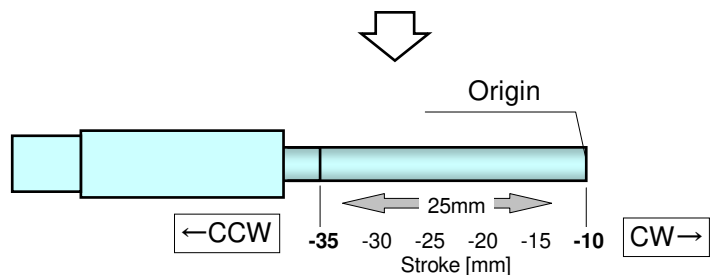

Initial setting for the ORIG parameters

Refer to the controller's (LEC series) operation manual for detail.

As the "ORIG parameter" is unique data of each actuator, if an actuator other than the "electric actuator / rod type" is used, refer to the operation manual of each actuator and the controller's (LEC series) operation manual for the ORIG parameter.

Description (Extract)	Initial input value	Input range
ORIG direction	Note1) CCW	1: CW , 2: CCW
ORIG mode	1:ORIG Press	-
ORIG limit	LEP□6 : 150 , LEP□10 : 150 , LEP□10L : 150	-
ORIG time	100	-
ORIG speed	LEP□□J : 20 , LEP□□K : 10	-
ORIG ACC /DEC	3000	-
Creep speed	20	-
ORIG sensor	0: Disable	-

Note1) Become effective after restarting the controller.

CCW direction: Retracted CW direction: Extended

Note 2) Return to origin cannot return while operating / See 6.1 ⚠caution(4) on p.35

⚠WARNING

Do not alter any parameter except the ones shown. Or else there is a possibility of damage.

2) Method of changing direction of origin

Use the following procedures when you change the direction of the origin.

Procedure 1- In the [Parameter] 01 dialogue box select the ORIG tab.

And the direction of the starting point return is changed from CCW to CW.

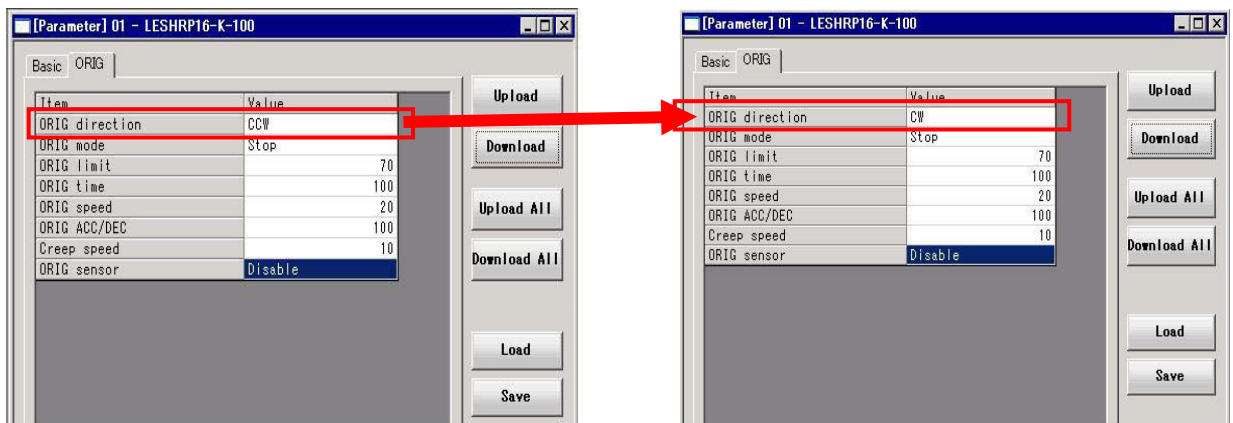

Procedure 2- In the [Parameter] 01 dialogue box press the "Download All" radio button.

Procedure 3- Power supply OFF (→ Power supply ON)

5. Wiring of cables / Common precautions

⚠ Warning

1. **Adjusting, mounting or wiring change should never be done before shutting off the power supply to the product.**
Electrical shock, malfunction and damaged can result.
2. **Never disassemble the cable. Use only specified cables.**
3. **Never connect or disconnect the cable or connector with power on.**

⚠ Caution

1. **Wire the connector securely. Do not apply any voltage to the terminals other than those specified in the product manual.**
2. **Wire the connector securely.**
Check for correct connector wiring and polarity.
3. **Take appropriate measures against noise.**
Noise in a signal line may cause malfunction. As a countermeasure, separate high voltage and low voltage cables, and shorten wiring lengths, etc.
4. **Do not route wires and cables together with power or high voltage cables.**
The product can malfunction due to interference of noise and surge voltage from power and high voltage cables to the signal line. Route the wires of the product separately from power or high voltage cables.
5. **Take care that actuator movement does not catch cables.**
6. **Operate with cables secured. Avoid bending cables at sharp angles where they enter the product.**
7. **Avoid twisting, folding, rotating or applying an external force to the cable.**
Risk of electric shock, wire break, contact failure and loss of control for the product can happen.
8. **Fix the cable protruding from the product in place before using.**
The motor and lock cables are not robotic type cables and can be damaged when moved. Therefore fix the cables and the connectors (part "A" in figure below) when set up

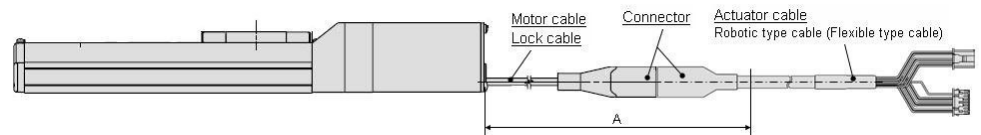

9. **Select "Robotic type cables" in case of inflecting actuator-cable repeatedly. And do not put cables into a flexible moving tube with a radius smaller than the specified value. (Min. 50mm).**
Risk of electric shock, wire break, contact failure and loss of control for the product can happen if "Standard cables" are used in case of inflecting the cables repeatedly

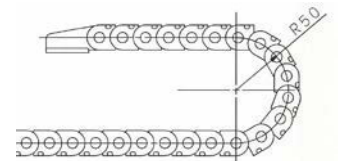

10. **Confirm proper wiring of the product.**
Poor insulation (interference with other circuits, poor insulation between terminals and etc.) can apply excessive voltage or current to the product causing damage.
11. **The Speed / pushing force may vary, depending on the cable length, load and mounting conditions etc..**
If the cable length exceeds 5m, the speed / pushing force will be reduced by a maximum of 10% per 5m. (If cable length is 15m: Maximum 20% reduction.)

[Transportation]

⚠ Caution

1. **Do not carry or swing the product by the motor or cable**

6. Electric actuators / Common precautions

6.1 Design and selection

Warning

- 1. Be sure to read the Operation Manual (this manual and the one for the controller: LEC series).**

Handling or usage/operation other than that specified in the Operation Manual may lead to breakage and operation failure of the product.
Any damage attributed to the use beyond the specifications is not guaranteed.
- 2. There is a possibility of dangerous sudden action by the product if sliding parts of machinery are twisted due to external forces etc.**

In such cases, human injury may occur, such as by catching hands or feet in the machinery, or damage to the machinery itself may occur. Design the machinery should be designed to avoid such dangers.
- 3. A protective cover is recommended to minimize the risk of personal injury.**

If a driven object and moving parts of the product are in close proximity, personal injury may occur. Design the system to avoid contact with the human body.
- 4. Securely tighten all stationary parts and connected parts so that they will not become loose.**

When the product operates with high frequency or is installed where there is a lot of vibration, ensure that all parts remain secure.
- 5. Consider a possible loss of power source.**

Take measures to prevent injury and equipment damage even in the case of a power source failure.
- 6. Consider behavior of emergency stop of whole system.**

Design the system so that human injury and/or damage to machinery and equipment will not be caused, when it is stopped by a safety device for abnormal conditions such as a power outage or a manual emergency stop of whole system.
- 7. Consider the action when operation is restarted after an emergency stop or abnormal stop of whole system.**

Design the system so that human injury or equipment damage will not occur upon restart of operation of whole system.
- 8. Never disassemble or modify (including additional machining) the product.**

An injury or failure can result.
It will cause the loss of the product performance.
- 9. Do not use the stop signal, "EMG" of the controller and stop switch on the teaching box as the emergency stop of system.**

The stop signal, "EMG" of controller and the stop switch on the teaching box are for decelerating and stopping the actuator.
Design the system with an emergency stop circuit which is applied relevant safety standard separately.
- 10. When using it for vertical application, it is necessary to build in a safety device.**

The rod may fall due to the weight of work. The safety device should not interfere with normal operation of the machine.

Caution

- 1. Operate within the limits of the maximum usable stroke.**

The product will be damaged if it is used with the stroke which is over the maximum stroke. Refer to the specifications of the product.
- 2. When the product repeatedly cycles with partial strokes, operate it at a full stroke at least once a day or every 1000 strokes.**

Otherwise, lubrication can run out.
- 3. Do not use the product in applications where excessive external force or impact force is applied to it.**

The product can be damaged. Each component that includes motor is made with accurate tolerance. So even slightly deformed or miss-alignment of component may lead operation failure of the product.

4. **Rerutting to origin cannot be done during the operation.**
It cannot be done during positioning operation, pushing operation and pushing.
5. **Refer to a common auto switch /matter (Best Pneumatics No 2) when an auto switch is built in and used.**
6. **When conformity to UL is required, the electric actuator and controller should be used with a UL1310 Class 2 power supply.**

6.2 Mounting

Warning

1. **Install and operate the product only after reading the Operation Manual carefully and understanding its contents. Keep the manual in a safe place future reference.**
2. **Observe the tightening torque for screws.**
Tighten the screws to the recommended torque for mounting the product.
3. **Do not make any alterations to this product.**
Alterations made to this product may lead to a loss of durability and damage to the product, which can lead to human injury and damage to other equipment and machinery.
4. **When using external guide, the guide axis should be parallel to the actuator axis.**
There will be damage/excessive wear on the lead screw if the external guide is not parallel.
5. **When an external guide is used, connect the moving parts of the product and the load in such a way that there is no interference at any point within the stroke.**
Do not scratch or dent the sliding parts of the product tube or piston rod etc., by striking or grasping them with other objects. Components are manufactured to precise tolerances, so that even a slight deformation may cause faulty operation.
6. **Prevent the seizure of rotating parts.**
Prevent the seizure of rotating parts (pins, etc.) by applying grease.
7. **Do not use the product until you verify that the equipment can operate properly.**
After mounting or repair, connect the power supply to the product and perform appropriate functional inspections to check it is mounted properly.
8. **At the overhang mounted impeller fixation**
There is a possibility that the power at the bending moment damages the actuator when moving it at high speed.
The support metal fittings that suppress the vibration of the main body of the actuator are installed.
Lower and use speed for the state that the actuator doesn't vibrate.
9. **When mounting the actuator or attaching to the work piece, do not apply strong impact or large moment.**
If an external force over the allowable moment is applied, it may cause looseness in the guide unit, an increase in sliding resistance or other problems.
10. **Maintenance space**
Allow sufficient space for maintenance and inspection.

6.3 Handling

Warning

1. Do not touch the motor while in operation.

The surface temperature of the motor can increase to approx. 80°C due to operating conditions. Energizing alone may also cause this temperature increase. As it may cause burns, do not touch the motor when in operation.

2. If abnormal heating, smoking or fire, etc., occurs in the product, immediately shut off the power supply.

3. Immediately stop operation if abnormal operation noise or vibration occurs.

If abnormal operation noise or vibration occurs, the product may have been mounted incorrectly. Unless operation of the product is stopped for inspection, the product can be seriously damaged.

4. Never touch the rotating part of the motor or moving part of the actuator while in operation.

5. When installing, adjusting, inspecting or performing maintenance on the product, controller and related equipment, be sure to shut off the power supply to them. Then, lock it so that no one other than the person working can turn the power on, or implement measures such as a safety plug.

6. In the case of the actuator that has a servo motor (24VDC), the "motor phase detection step" is done by inputting the servo on signal just after the controller power is turned on.

The "motor phase detection step" moves the table/rod for the distance of the one screw-lead as the maximum. (The motor rotates in the reverse direction if the table hits an obstacle such as the end stop damper.) Take the "motor phase detection step" into consideration for the installation and operation of this actuator.

Caution

1. Keep the controller and product combined as delivered for use.

The product is set in parameters for shipment. If it is combined with a different parameter, failure can result.

2. Check the product for the following points before operation.

- a) Damage to electric driving line and signal line.
- b) Looseness of the connector to each power line and signal line.
- c) Looseness of the actuator /cylinder and controller /driver mounting
- d) Abnormal operation
- e) Emergency stop of the total system

3. When more than one person is performing work, decide on the procedures, signals, measures and resolution for abnormal conditions before beginning the work. Also, designate a person to supervise work other than those performing work.

4. Actual speed of the product will be changed by the workload.

Before selecting a product, check the catalog for the instructions regarding selection and specifications.

5. Do not apply a load, impact or resistance in addition to a transferred load during return to origin.

In the case of the return to origin by pushing force, additional force will cause displacement of the origin position since it is based on detected motor torque.

6. Do not remove the nameplate.

7. Operation test should be done by low speed. Start operation by predefined speed after confirming there is no trouble.

[Earth]

Warning

1. Please give the earth to the actuator.

2. Please make it to the earth of exclusive use. The earth construction is D seed.
(Below earth resistance 100Ω)

3. Please shorten the distance until the actuator and earth.

[Unpackaging]

Caution

1. Check the received product is as ordered.

If the different product is installed from the one ordered, injury or damage can result.

6.4 Operating environment

Warning

1. Avoid use in the following environments.

- a. Locations where a large amount of dusts and cutting chips are airborne.
- b. Locations where the ambient temperature is outside the range of the temperature specification (refer to specifications).
- c. Locations where the ambient humidity is outside the range of the humidity specification (refer to specifications).
- d. Locations where corrosive gas, flammable gas, sea water, water and steam are present.
- e. Locations where strong magnetic or electric fields are generated.
- f. Locations where direct vibration or impact is applied to the product.
- g. Areas that are dusty, or are exposed to splashes of water and oil drops.
- h. Areas exposed to direct sunlight (ultraviolet ray).

2. Do not use in an environment where the product is directly exposed to liquid, such as cutting oils.

If cutting oils, coolant or oil mist contaminates the product, failure or increased sliding resistance can result.

3. Install a protective cover when the product is used in an environment directly exposed to foreign matters such as dust, cutting chips and spatter.

Play or increased sliding resistance can result.

4. Shade the sunlight in the place where the product is applied with direct sunshine.

5. Shield the valve from radiated heat generated by nearby heat sources.

When there is a heat source surrounding the product, the radiated heat from the heat source can increase the temperature of the product beyond the operating temperature range. Protect it with a cover, etc.

6. Grease oil can be decreased due to external environment and operating conditions, and it deteriorates lubrication performance to shorten the life of the product.

[Storage]

Warning

1. Do not store the product in a place in direct contact with rain or water drops or is exposed to harmful gas or liquid.

2. Store in an area that is shaded from direct sunlight and has a temperature and humidity within the specified range (-10°C to 60°C and 90%RH or less No condensation or freezing).

3. Do not apply vibration and impact to the product during storage.

6.5 Maintenance

Warning

1. Do not disassemble or repair the product.

Fire or electric shock can result.

Contact SMC, in case of disassembly for the maintenance.

2. Before modifying or checking the wiring, the voltage should be checked with a tester 5 minutes after the power supply is turned off.

Electrical shock can result.

Caution

1. Maintenance should be performed according to the procedure indicated in the Operating Manual.

Incorrect handling can cause an injury, damage or malfunction of equipment and machinery.

2. Removal of product

When equipment is serviced, first confirm that measures are in place to prevent dropping of work pieces and run-away of equipment, etc, and then cut the power supply to the system. When machinery is restarted, check that operation is normal with actuators in the proper positions.

[Lubrication]

Caution

1. The product has been lubricated for life at manufacturer, and does not require lubrication in service.

When lubrication is applied, special grease must be used.

6.6 Precautions for actuator with lock

Warning

1. Do not use the lock as a safety lock or a control that requires a locking force.

The lock used for the product with a lock is designed to prevent dropping of work piece.

2. For vertical mounting, use the product with a lock.

If the product is not equipped with a lock, the product will move and drop the work piece when the power is removed.

3. "Measures against drops" means preventing a work piece from dropping due to its weight when the product operation is stopped and the power supply is turned off.

4. Do not apply an impact load or strong vibration while the lock is activated.

If an external impact load or strong vibration is applied to the product, the lock will lose its holding force and damage to the sliding part of the lock or reduced lifetime can result. The same situations will happen when the lock slips due to a force higher than its holding force, as this will accelerate the wear to the lock.

5. Do not apply liquid or oil and grease to the lock or its surrounding.

When liquid or oil and grease are adhered to the sliding part of the lock, its holding force will reduce significantly. Or, lock sliding part performance and condition changes may be cause of lock release malfunction.

6. Take measures against drops and check that safety is assured before mounting, adjustment and inspection of the product.

If the lock is released with the product mounted vertically, a work piece can drop due to its weight.

7. When the actuator is operated manually (when SVRE output signal is off), supply 24DCV to the [BK RLS] terminal of the power supply connector.

If the product is operated without releasing the lock, wearing of the lock sliding surface will be accelerated, causing reduction in the holding force and the life of the locking mechanism.

8. Do not supply 24VDC power supply constantly to the [BK RLS(Lock release)] terminal.

Stop supplying 24VDC power supply to the [BK RLS(Lock release) terminal during normal operation. If power is supplied to the [BK RLS] terminal continuously, the lock will be released, and workpieces may be dropped at stop (EMG).

/Refer to the operation manual of LEC (controller) for details of wiring.

7. Electric actuators / Common precautions

7.1 Design and selection

Warning

- 1. Do not apply a load in excess of the operating limit.**
Select a suitable actuator by work load and allowable lateral load on the rod end. If the product is used outside of the operating limit, the eccentric load applied to the rod will be excessive and have adverse effects such as creating play on the sliding parts of the rod, degrading accuracy and shortening the life of the product.
- 2. Do not use the product in applications where excessive external force (including vibration) or impact force is applied to it.**
Do not apply impact and vibration outside of the specifications; it may lead to a malfunction.
- 3. If gravity acts on the workpiece due to vertical mounting, it may drop due to its own weight depending on the conditions when the product is not energized (SVON signal is OFF) or stopped (EMG is not energized).**
- 4. Power failure may result in a decrease in the pushing force; ensure that safety measures are in place to prevent injury to the operator or damage to the equipment.**
When the product is used for clamping, the clamping force could be decreased due to power failure, potentially creating a hazardous situation in which the workpiece is released.
- 5. This product cannot be used as a stopper.**
Excessive load acts on the actuator, which adversely affects the operation and the life of the product.

7.2 Mounting

Caution

- 1. Do not drop or hit the actuator to avoid scratching and denting the mounting surfaces.**
Even slight deformation can cause the deterioration of accuracy and operation failure.
- 2. When mounting workpieces or jigs to the rod end, hold the flats of the rod end with a wrench so that the rod does not rotate (Rod type only).**
When attaching a bolt or workpiece to the end of the rod, hold the flats of the rod end with a wrench (the rod should be fully retracted). Do not apply tightening torque to the rod non-rotating mechanism. The rod is manufactured to precise tolerances, so even a slight deformation may cause a malfunction and damage.

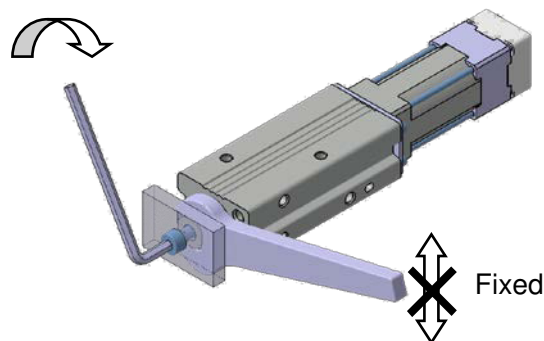

3. When mounting a bolt, workpiece or jig to the rod end, the bolt should be tightened with a torque within the specified range (Rod type only).

Tightening to a torque higher than the specified value may cause a malfunction due to deformation of the component, whilst under-tightening can cause displacement of the mounting position or in extreme conditions detaching of the workpiece. If the bolt is screwed in more than the maximum depth, the lead screw will be damaged, leading to operation failure.

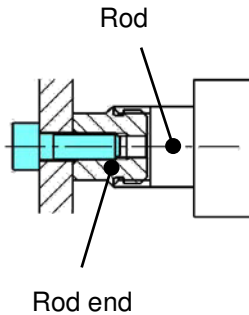

Model	Bolt	Max. tightening torque [Nm]	Max.screw-in depth [mm]	Rod end width across flats [mm]
LEPY6	M4X0.7	1.4	7	10
LEPY10	M5X0.8	3.0	9	12

4. The angular position of the rod end flats cannot be changed because the rod has a non-rotating mechanism inside (Rod type only).

The angular position of the rod end flats is not specified; it depends on the actuator type. The rod rotates slightly due to the clearance of the non-rotating mechanism: Install the bolt or workpiece with consideration to the rotation.

5. When attaching the workpiece to the table, hold the table and tighten the bolts with a torque within the specified range (Slide table type only).

The table is supported by a linear guide, do not apply impact or moment when mounting the work load. If the bolts are screwed to more than the maximum screw-in depth, it may lead to a malfunction due to damage of the linear guide or body.

Top mounting

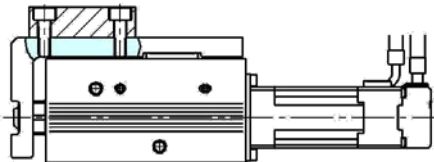

Model	Bolt	Max. tightening torque [Nm]	Max.screw-in depth [mm]
LEPS6	M4X0.7	1.4	6
LEPS10	M4X0.7	1.4	6

Front mounting

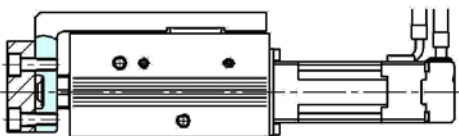

Model	Bolt	Max. tightening torque [Nm]	Max.thread depth [mm]
LEPS6	M4X0.7	1.4	7
LEPS10	M4X0.7	1.4	8

6. When mounting the product, tighten the mounting screws within the specified torque range.

Tightening the screws with a higher torque than recommended may cause a malfunction, whilst the tightening with a lower torque can cause the displacement of the mounting position or in extreme conditions the actuator could become detached from its mounting position.

Side mounting (Body mounting through-hole)

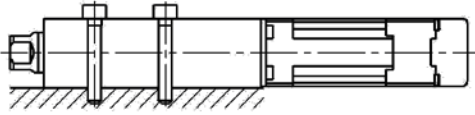

Model	Bolt	Max. tightening torque [Nm]
LEPY6	M3X0.5	0.9
LEPS6		
LEPY10	M4X0.7	1.4
LEPS10		

Side mounting (Body tapped)

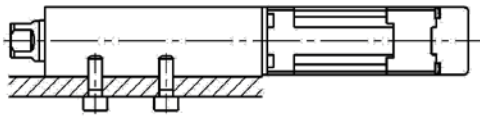

Model	Bolt	Max. tightening torque [Nm]	Max.screw-in depth [mm]
LEPY6	M4X0.7	1.4	7
LEPS6			
LEPY10	M5X0.8	3.0	9
LEPS10			

Bottom mounting (Body tapped)

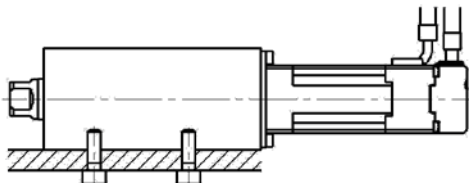

Model	Bolt	Max. tightening torque [Nm]	Max.screw-in depth [mm]
LEPY6	M4X0.7	1.4	5
LEPS6			
LEPY10	M5X0.8	3.0	9
LEPS10			

Rod side mounting (Rod type only)

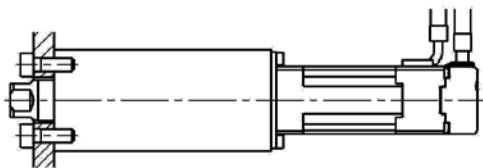

Model	Bolt	Max. tightening torque [Nm]	Max.screw-in depth [mm]
LEPY6	M4X0.7	1.4	7
LEPY10	M5X0.8	3.0	9

7. When it is necessary to operate the product by the manual override screw, check the position of the manual override and leave necessary space.

Do not apply excessive torque to the manual override screw. This may lead to damage and malfunction.

8. When an external guide is used, connect it in such a way that no impact or load is applied to it.

This may cause a malfunction due to an increase in sliding resistance, or use a freely moving connector (such as a floating joint).

7.3 Handling



Caution

1. **When the pushing operation is used, be sure to set to [Pushing operation].**
Also, do not hit the workpiece in positioning operation or in the range of positioning operation.
 It may damage and malfunction. If the operation is interrupted or stopped during the cycle: When the pushing operation command is output immediately after restarting the operation, the direction of movement depends on the position of restart.
2. **Use the product within the specified pushing speed range for the pushing operation.**
 It may lead to damage and malfunction.

Model	Lead	Pushing speed [mm/sec]
LEPY6 LEPS6	4	10
	8	20
LEPY10 LEPS10	5	10
	10	20

3. **For the pushing operation, ensure that the force is applied in the direction of the rod axis.**
4. **The moving force should be the initial value.**
 If the moving force is set below the initial value, it may cause an alarm.

Model	Motor size	Moving force [%]
LEPY6 LEPS6	Basic	150%
LEPY10 LEPS10	Basic	150%
	Compact	

5. **The actual speed of this actuator is affected by the load.**
 Check the model selection section of the catalog.
6. **Do not scratch or dent the sliding parts of the rod, by striking or attaching objects.**
 The rod is manufactured to precise tolerances, even a slight deformation may cause malfunction.
7. **Avoid using the electric actuator in such a way that rotational torque would be applied to the rod.**
 It may cause deformation of the non-rotating sliding part, leading to clearance in the internal guide or an increase in the sliding resistance. Refer to the table below for the approximate values of the allowable range of rotational torque.

Allowable rotational torque [N·m] or less	LEPY6□	LEPY10□
		0.04

8. **Do not operate by fixing the rod and moving the actuator body.**
 Excessive load will be applied to the rod, leading to damage to the actuator and reduced the life of the product.
9. **Return to origin**
 - 1) Do not apply a load, impact or resistance in addition to the transferred load during return to origin. Additional force will cause the displacement of the origin position since it is based on detected motor torque.

- 2) When the return to origin is set with <Basic parameter> [Origin offset], it is necessary to change the current position of the product. Recheck the value of step data.
- 3) It is recommended to set the directions of return to origin and pushing in the same direction in order to enhance the measurement accuracy during pushing operation.

10. There is no backlash effect in pushing operation.

The return to origin is done by the pushing operation.

The position can be displaced by the effect of the backlash during the positioning operation.

Take the backlash into consideration when setting the position.

< Backlash >

Model	Backlash [mm]
LEPY6	0.2 or less
LEPS6	0.2 or less
LEPY10	0.2 or less
LEPS10	0.2 or less

11. Do not hit at the stroke end except during return to origin.

This may damage the inner parts.

12. INP output signal

1) Positioning operation

When the product comes within the set range by step data [Inposition], the INP output signal will turn on. Initial value: Set to [0.50] or higher.

2) Pushing operation

When the effective pushing force exceeds the step data [Trigger LV], the INP output signal will turn on. When [Pushing force] setting and [Trigger LV] are set less than [Pushing force], use the product within the specified range of [Pushing force] and [Trigger LV].

- a) To ensure that the actuator pushes the workpiece with the set [Pushing force], it is recommended that the [Trigger LV] be set to the same value as the [Pushing force].
- b) If the [Trigger LV] is set lower than the [operation pushing force (current pushing force) for the pushing operation], the pushing force will exceed the trigger LV from the pushing start position and the INP output signal will turn on before pushing the workpiece. Increase the pushing force, or change the work load so that the current pushing force becomes smaller than the trigger LV.

< Pushing force and trigger LV range >

Model	Motor size	Set value of pushing force[%]
LEPY6 LEPS6	Basic	70 to 100%
LEPY10 LEPS10	Basic	50 to 100%
	Compact	60 to 100%

13. In pushing operation, set the product to a position of at least 0.5 mm away from a workpiece. (This position is referred to as a pushing start position.)

The following alarms may be generated and operation may become unstable.

a. “Posn failed” alarm is generated

The product cannot reach a pushing start position due to variation in the width of workpieces.

b. “Pushing ALM” alarm is generated

The product is pushed back from a pushing start position after starting to push.

c. “Deviation over flow” alarm is generated

Displacement exceeding the specified value is generated at the pushing start position.

14. For the pushing operation, use the product within the duty ratio range below.

The duty ratio is a ratio at the time that can keep being pushed.

Model	Motor size	Set value of pushing force [%]	Duty ratio (%)	Continuous Pushing time (minute)
LEPY6 LEPS6	Basic	70	100	-
		80	70	10
		100	50	5

Model	Motor size	Set value of pushing force [%]	Duty ratio (%)	Continuous Pushing time (minute)
LEPY10 LEPS10	Basic	60 or less	100	-
		70	30	3
		100	15	1

Model	Motor size	Set value of pushing force [%]	Duty ratio (%)	Continuous Pushing time (minute)
LEPY10 LEPS10	Compact	70 or less	100	-
		80	70	10
		100	50	5

12. When mounting the product, keep a 40 mm or longer diameter for bends in the motor cable.

7.4 Precaution on maintenance

 Caution

1. Ensure that the power supply is stopped and the workpiece is removed before starting maintenance work or replacement of the product.

8. Troubleshooting

Alarms below are abstract of representative examples.

For other alarms, see operation manual of controller.

No.	Phenomenon	Cause	Countermeasure
1	Fall to operate / Initial stage	1) The cable is not connected or has been disconnected	Confirm that the cable is connected correctly. /See 5. Wiring of cable on p. 33
	When power is supplied, alarm for "Phase Det ALM /code: 1-193" is generated. ↓ <Procedure of restart> "Turn the power supply off." ↓ "Turn the power supply on"	2) The load / resistance being applied to the actuator constantly exceeds the actuators specification.	Keep the load / resistance within specified range. /See 2.1 Specifications on p.9 /See 3.1 Specifications on p.12
		3) The combination of the controller and actuator is not correct.	The controller and actuator combination at the time of shipment should not be changed. /See 6.3 ⚠Caution (1) on p.36
		4) Excessive external force is being applied, (including vibration) or impact load.	Operate within the specified range. /See 2.1 Specifications on p.9 /See 3.1 Specifications on p.12
	After power supplied, when first input signal [SVON] is on and output signal [SVRE] takes long time.	Motor may take about 20sec to find the motor phase.	This is not a malfunction. Use it as normal.
	Alarm for "Step data ALM1 /code:1-048" is generated ↓ <Procedure of restart> Input the "RESET" signal.	Setting condition for step data is not correct. < Correct set condition > (1)Area 1 < Area 2 (2) Trigger LV ≤ Pushing force (3) Pushing speed ≤ Speed (4) Pushing force ≥ Min. pushing force	Review the content of step data. / Refer to the LEC controller operation manual.
	Alarm for "Servo off ALM /code: 1-098" is generated ↓ <Procedure of restart> Input the "RESET" signal.	Perform the "Return to origin", the positioning operation and JOG operation during the "SVON": OFF.	Provide the operation instruction after confirming that the input signal [SVON] is ON and then the output signal [SVRE] is ON.
	Alarm for "Drive ALM /code: 1-099" is generated. ↓ <Procedure of restart> Input the "RESET" signal.	Perform positioning, pushing operation before the "return to origin".	Provide the operation instruction after confirming that the input signal [SETUP] is ON and then the output signal [SETON] is ON.
"ORIG direction" cannot be change.	After the "ORIG direction" is changed, the controller power supply has not been turned OFF.	Become effective after restarting the controller. /See "Initial setting for the ORIG parameters" on p.32	

No.	Phenomenon	Cause	Countermeasure
2	<p>Operation not completed / Operation continue</p> <p>Alarm for "Posn failed /code: 1-149" is generated.</p> <p style="text-align: center;">↓</p> <p><Procedure of restart> Controller version /SV1.0 or later 1. Input the "reset signal." →"SVRE": Automatically ON</p> <p>Controller version /SV0.8* or before 1. Input the "reset signal." →"SVRE": Automatically ON 2. Input the "setup signal." → Restart operation after the completion of the"return to origin".</p> <div style="border: 1px solid black; padding: 5px; margin-top: 10px;"> <p><u>Label position for controller version</u></p>  <p>Position : Bottom SV1.0*</p> </div>	1) The lead screw had galling due to excessive external force (including vibration) or impact.	Operate within the specified range. /See 2.1 Specifications on p.9 /See 3.1 Specifications on p.12
		2) The Power supply does not have sufficient capacity.	Check the power consumption for each actuator and controller: If necessary replace the existing power supply with a power supply with sufficient capacity. /See 2.1 Specifications on p.9 /See 3.1 Specifications on p.12
		3) Load/resistance more than specified range is being applied to the actuator.	Use within specification range. /See 2.1 Specifications on p.9 /See 3.1 Specifications on p.12 /See Catalog Model Selection "Speed-Vertical work load graph"
		4) The pushing operation is performed at the "Positioning operation" position.	Review the content of the step data. /See 7.3⚠Caution (1) on p.42
		5) For the pushing operation: The position and the target start pushing position are not set correctly.	Check the step data. /See 7.3⚠Caution (13) on p.44
		6) The cable is not connected or has been disconnected.	Confirm that the cable is connected correctly. /See 5. Wiring of cable on p.33
		7) It was not the intended origin position because the actuator pinched the work-piece during the"return to origin".	Remove the work-piece and restart the return to the intended origin position.
		8) Wrong input [0] is input as the positioning force.	Check the step data. <Moving force> /See 4.3Step data setting on p.19
		9) The step data position is not changed correctly after the return to origin direction is changed.	Check the step data. <Position> /See 4.3 Step data setting on p.19 /See 4.4 Parameter setting on p.30
		10) Because the operation of the step data is set to [INC/relative], the table comes into contact with an external object and does not move due to continuous operation. (Stroke end etc.)	Check the step data. <Position> /See 4.3 Step data setting on p.19 Check if correct operation instruction is provided.

No.	Phenomenon	Cause	Countermeasure
2	Alarm for "Pushing ALM /code: 1-096" is generated. ↓ <Procedure of restart> Controller version /SV1.0 or later 1. Input the "reset signal." →"SVRE": Automatically ON Controller version /SV0.8* or before 1. Input the "reset signal." →"SVRE": Automatically ON 2. Input the "setup signal." → Restart operation after the completion of the "return to origin".	1) For the pushing operation, the position, target start-pushing position, is not set correctly.	Check the step data. /See 7.3 ⚠ Caution (13) on p.44
	Operation is not completed / Operation continue Alarm for "Over motor Vol /code: 1-145" is generated. ↓ <Procedure of restart> Controller version /SV1.0 or later 1. Input the "reset signal." →"SVRE": Automatically ON Controller version /SV0.8* or before 1. Input the "reset signal." →"SVRE": Automatically ON 2. Input the "setup signal." → Restart operation after the completion of the "return to origin".	2) It was not the intended origin position because the actuator pinched the work-piece during the "return to origin".	Remove the work-piece and restart the return to the intended origin position.
	Operation is not completed / Operation continue Alarm for "Over motor Vol /code: 1-145" is generated. ↓ <Procedure of restart> Controller version /SV1.0 or later 1. Input the "reset signal." →"SVRE": Automatically ON Controller version /SV0.8* or before 1. Input the "reset signal." →"SVRE": Automatically ON 2. Input the "setup signal." → Restart operation after the completion of the "return to origin".	1) If the power supply is an "inrush-current restraining type", the alarm may be generated due to voltage drop.	Replace the power supply with a non "inrush-current restraining type" power supply. / Refer to the LEC controller operation manual.
	Operation is not completed / Operation continue Alarm for "Over motor Vol /code: 1-145" is generated. ↓ <Procedure of restart> Controller version /SV1.0 or later 1. Input the "reset signal." →"SVRE": Automatically ON Controller version /SV0.8* or before 1. Input the "reset signal." →"SVRE": Automatically ON 2. Input the "setup signal." → Restart operation after the completion of the "return to origin".	2) The Power supply does not have sufficient capacity.	Check the power consumption for each actuator and controller: If necessary replace the existing power supply with a power supply with sufficient capacity. /See 2.1 Specifications on p.9 /See 3.1 Specifications on p.12

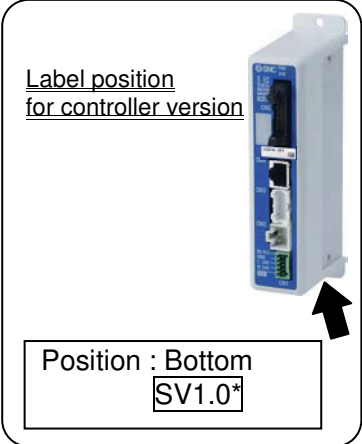

No.	Phenomenon	Cause	Countermeasure
2	Alarm for “ Err overflow /code: 1-196” is generated. ↓ <Procedure of restart> “Turn the power supply off.” ↓ “Turn the power supply on”	1) Added excessive external force (including vibration) or impact load.	Operate within the specified range. /See 2.1 Specifications on p.9 /See 3.1 Specifications on p.12
		2) The Power supply does not have sufficient capacity.	Check the power consumption for each actuator and controller: If necessary replace the existing power supply with a power supply with sufficient capacity. /See 2.1 Specifications on p.9 /See 3.1 Specifications on p.12
		3) Load/resistance more than specified range is being applied to the actuator.	Use within specification range. /See 2.1 Specifications on p.9 /See 3.1 Specifications on p.12 /See Catarog Model Selection “Speed-Vertical work load graph”
		4) The pushing operation is performed at the “Positioning operation position”	Review the content of the step data. /See 7.3⚠Caution (1) on p.42
		5) For the pushing operation: The position (the target start pushing position) is not set correctly.	Check the step data. /See 7.3⚠Caution (13) on p.44
		6) The cable is not connected or has been disconnected.	Confirm that the cable is connected correctly. /See 5. Wiring of cable on p.33
		7) It was not the intended origin position because the actuator pinched the work-piece during the “return to origin”.	Remove the work-piece and restart the return to the intended origin position.
		8) Wrong input [0] is input as the positioning force.	Check the step data. <Moving force> /See 4.3 Step data setting on p.19
		9) The step data position is not changed correctly after the return to origin direction is changed.	Check the step data. <Position> /See 4.3 Step data setting on p.19 /See 4.4 Parameter setting on p.30
		10) Because the operation of the step data is set to [INC/relative], the table comes into contact with an external object and does not move due to continuous operation. (Stroke end etc.)	Check the step data. <Position> /See 4.3 Step data setting on p.19 Check if correct operation instruction is provided.

No.	Phenomenon	Cause	Countermeasure
2	Operation not completed / During operation (Not always, but may happen occasionally) Alarm for "Step data ALM2 /code: 1-051" is generated. ↓ <Procedure of restart> Input the "reset" signal.	1) Command invalid (unregistered) step data.	Check if the step data is valid (registered).
		2) Different input signal to the expected step number is inputted to the controller, because of too short of an interval between the input signal of the "IN*" and the "Drive" or inputting the signals at the same time.	Add an interval of 15ms (the recommendation is 30ms) or more between the input signals. / See "Operating procedure input and output signals for each operation type" on P.28
		3) Different input signal to the expected step number is inputted to the controller, because the input signal time was too short.	Maintain the state of the input signal for 15ms (the recommendation is 30ms) or more . / See "Operating procedure input and output signals for each operation type" on P.28
		4) Different input signal to the expected step number is inputted to the controller, caused by PLC or other device.	Check that the step number is inputted correctly for the required motion.
	- Operation completed by unexpected motion. - No alarm / During operation (Not always, but may happen occasionally)	1) Different input signal to the expected step number is inputted to the controller, because of a too short an interval between the input signal of the "IN*" and the "Drive" or inputting the signals at the same time.	Add an interval of 15ms (the recommendation is 30ms) or more between the input signals. / See "Operating procedure input and output signals for each operation type" on P.28 Note) Recommend to check the "OUT" output signal for more secure operation.
		2) Different input signal to the expected step number is inputted to the controller, because the input signal time was too short.	Maintain the state of the input signal for 15ms (the recommendation is 30ms) or more . / See "Operating procedure input and output signals for each operation type" on P.28 Note) Recommend to check the "OUT" output signal for more secure operation.
		3) Different input signal to the expected step number is inputted to the controller, caused by PLC or other device.	Check that the step number is inputted correctly for the required motion. / See "Operating procedure input and output signals for each operation type" on P.28 Note) Recommend to check the "OUT" output signal for more secure operation.

No.	Phenomenon	Cause	Countermeasure
3	"Output signal" unstable the "INP output signal" turns "ON" before pushing the work piece.	1) "INP output signal" turns "ON" because the actual thrust force exceeds "TriggerLV".	Set the pushing force to be larger within the specified range. /See 7.3  Caution (12) on p.43
	"Output signal" is unstable when pushing the work piece. 1. INP output signal When pushing work piece: "ON" ↓ Momentary "OFF" ↓ "ON" 2. BUSY output signal When pushing work piece: "OFF" ↓ Momentary "ON" ↓ "OFF"	1) Situation of pushing the work-piece is unstable. Pushing the work piece in a position that allows the attachment to catch on the work piece. ↓ Work piece slipped. ↓ Re-holding the work piece.	Change the shape of the attachment to avoid being caught by the work-piece and to avoid slipping work-piece. Ex1) Attachment made by an elastic material. Ex2) Change the point of a rod where force is applied to the same axle. <If it is not possible to change the shape of attachment> The unstable pushing condition cannot be improved. <How to reduce the instability of the "Output signal"> 1. To reduce the influence when pushing the work piece. "Pushing force" = "TriggerLV" 2. Set the pushing force to be larger within the specified range. An unstable output signal may occur easily because of an external shock or vibration when the pushing force is set too low.
	"INP" output signal is unstable. "INP" output signal is unstable even after the positioning operation is completed.	1) The value of [In position] in step data is too small	Increase [In position] value as the following. ([0.5] or more)
	"INP" output signal is [OFF]. "INP" output signal is [OFF] even after the pushing operation is completed.	The value of "In pos" is input forward of work.	Input the value of "In pos" larger than length to work. /See Example of step data entry(4) on p.26
4	Positioning repeatability is out of specified range.	1) It shifts to the next operation by receiving the "INP" output signal.	Go to the next operation after receiving the "BUSY" output signal is outputted.
5	Damage	1) Abnormal external force	Interference of mechanism, eccentric load or excess load leads to cause deformation or damage of the actuator. Eliminate these factors.
6	The rod of the actuator with vertical mounting vibrates repeated up and down.	1) Actuator carries excess load.	Check if the workload is within the specification range. /See 2.1 Specifications on p.9 /See 3.1 Specifications on p.12

No.	Phenomenon	Cause	Countermeasure
7	Cannot be actuated manually or by manual override adjustment screw (does not operate). (At stop(EMG) or SVRE[OFF])	1) Contacts the stroke end of the actuator or the workpiece.	Check the stroke position and how workpieces are mounted.

Montagemöglichkeiten

Montage auf 2 Seiten möglich

Seitliche Montage (Durchgangsbohrung)

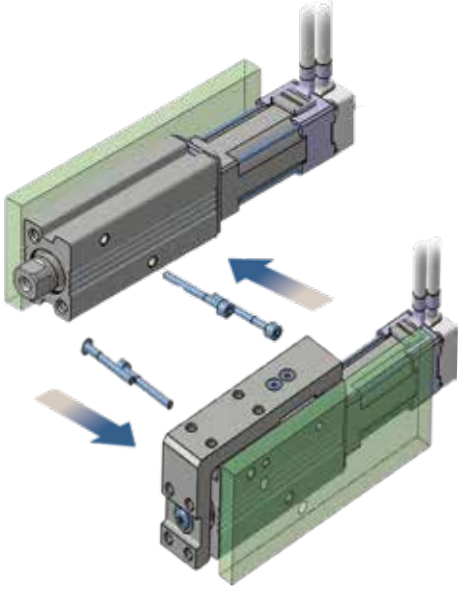

Montage von oben (Gewindebohrung)

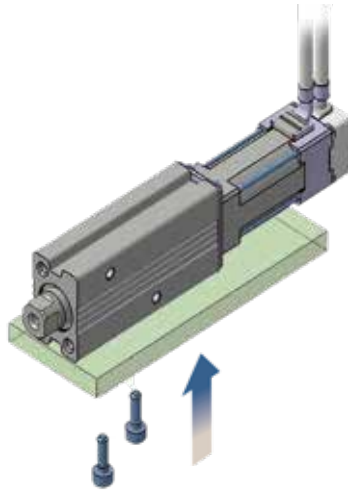

Axiale Montage nur Ausführung mit Kolbenstange (Gewindebohrung)

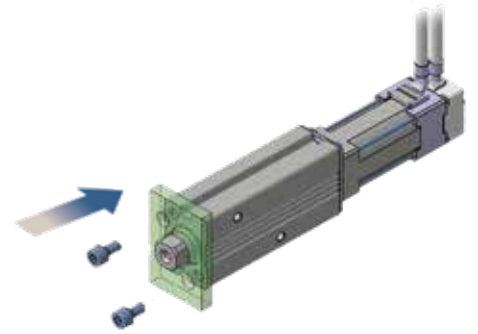

Bei der Ausführung mit Schlitten ist die Montage auf beiden Seiten möglich.

Anwendungsbeispiele

Pick-and-Place-Anwendungen

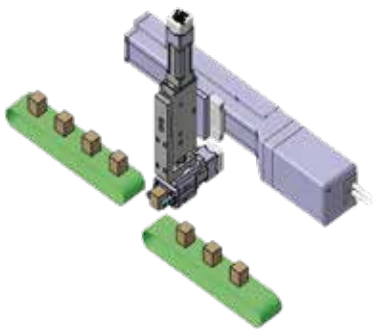

Versand

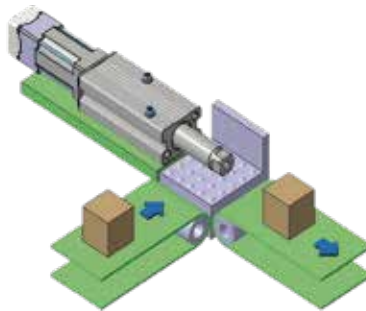

Ausrichtung

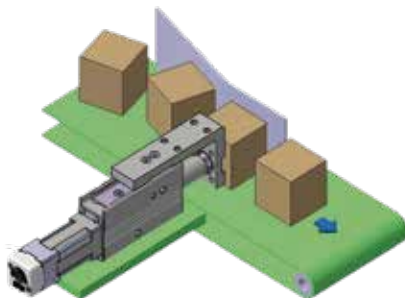

Einpressoperationen

