

Traffa

Konformitätserklärung seit April 2016
Elektrische Antriebe Miniaturausf. LEP

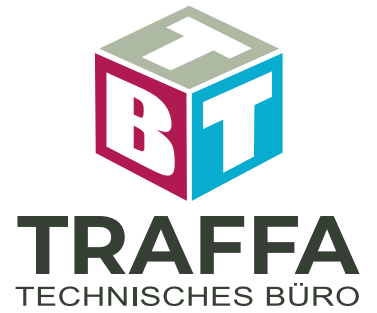

Innovative Antriebslösungen

Der optimale Antrieb individuell für Ihre Anforderung



EU DECLARATION OF CONFORMITY

SMC Corporation
4-14-1 Soto-Kanda, Chiyoda-ku, Tokyo 101-0021 Japan

declares under its sole responsibility, that the following equipment:

Electric Actuators

Series LEP#####-##-##### (Motor: Step [servo 24VDC] / Servo [24VDC])

Batch codes: PX onwards and bearing the G mark on the product or packaging

is in conformity with the relevant Union harmonisation legislation and has been demonstrated to fulfil the requirements with reference to the harmonised or applied standard(s) as listed below:

Directive	Requirements	Harmonised standards
EMC Directive 2014/30/EU	Essential requirements set out in Annex I	EN 61000-6-2: 2005 EN 61000-6-3: 2007
RoHS Directive 2011/65/EU	Restriction of substances as set out in Annex II	EN 50581: 2012

Importer/Distributor in EU and EFTA:

Country	Company	Telephone	Address
Austria	SMC Pneumatik GmbH (Austria)	(43) 2262-62280	Girakstrasse 8, AT-2100 Korneuburg
Belgium	SMC Pneumatics N.V./S.A.	(32) 3-355-1464	Nijverheidsstraat 20, B-2160 Wommelgem
Bulgaria	SMC Industrial Automation Bulgaria EOOD	(359) 2 9744492	Business Park Sofia, Building 8-6th Floor, BG-1715 Sofia
Croatia	SMC Industrijska Automatika d.o.o.	(385) 1 370 72 88	Zagrebačka Avenija 104, 10 000 Zagreb
Czech Republic	SMC Industrial Automation CZ s.r.o.	(420) 541-424-611	Hudcova 78a CZ-61200 Brno
Denmark	SMC Pneumatik A/S	(45) 70 25 29 00	Egeskovvej 1, DK-8700 Horsens
Estonia	SMC Pneumatics Estonia OÜ	(372) 651-0370	Laki 12, EE-10621 Tallinn
Finland	SMC Pneumatikka Finland Oy	(358) 207 513 513	PL72, Tiistinniityntie 4, SF-02031 Espoo
France	SMC France	(33) 1-6476-1000	1 Boulevard de Strasbourg, Parc Gustave Eiffel, Bussy Saint Georges, F-77607, Marne La Vallee, Cedex 3
Germany	SMC Deutschland GmbH	(49) 6103-402-0	Boschring 13-15, D-63329 Egelsbach
Greece	SMC Italia Hellas Branch	(30) 210-2717265	Anagenniseos 7-9 - P.C. 14342, Nea Philadelphia, Athens
Hungary	SMC Hungary Ipari Automatizálási Kft.	(36) 23-511-390	Torbágy u. 19, HU-2045 Törökbálint
Ireland	SMC Pneumatics (Ireland) Ltd.	(353) 1-403-9000	2002 Citywest Business Campus, Naas Road, Saggart, Co. Dublin
Italy	SMC Italia S.p.A.	(39) 02-9271-1	Via Garibaldi, 62, I-20061 Carugate, Milano
Latvia	SMC Pneumatics Latvia SIA	(371)781-77-00	Dzelzavas str. 120g, Riga, LV-1021
Lithuania	SMC Pneumatics Lietuva,UAB	(370)5-264-81-26	Oslo g.1, LT-04123 Vilnius
Netherlands	SMC Pneumatics B.V.	(31) 20-531-8888	De Ruyterkade 120, NL-1011 AB Amsterdam
Norway	SMC Pneumatics Norway AS	(47) 67-12-90-20	Vollsveien 13c, Granfoss Næringspark, N-1366 Lysaker
Poland	SMC Industrial Automation Polska Sp. zo.o	(48) 22 211 96 00	ul. Poloneza 89, PL-02-826 Warszawa
Portugal	SMC Sucursal Portugal, S.A.	(351) 945-184 100	Rua De Eng Ferrerira Dias 452 4100-246,Porto
Romania	SMC Romania S.r.l.	(40)21-3205111	Str. Frunzei, Nr.29, Sector 2 Bucharest
Slovakia	SMC Priemyselna Automatizacia, Spol s.r.o.	(421) 41-321321-1	Fantranská 1223, Teplicka nad vahom, 01301
Slovenia	SMC Industrijska Avtomatika d.o.o.	(386) 7388 5412	Mirnska cesta 7, SLO-8210 Trebnje
Spain	SMC España, S.A.	(34) 945-184-100	Zuazobidea 14, 01015 Vitoria
Sweden	SMC Pneumatics Sweden AB	(46) 8-603-12-00	Ekhagsvägen 29-31, SE-14171 Segeltorp
Switzerland	SMC Pneumatik AG	(41) 052-396-3131	Dorfstrasse 7, Postfach 117, CH-8484, Weisslingen
United Kingdom	SMC Pneumatics (U.K.) Ltd.	(44) 1908-563888	Vincent Avenue, Crownhill, Milton Keynes, Bucks MK8 0AN



LIST OF MODEL NUMBER

LEP##### -## -#####

1###
2###
6###
A###
C###
(None)

Note) In the case of special product, it is added the "-X#" at end of model number.
However, any product without the CE mark is excluded.

Tokyo, 22nd July 2017

DKP50047-F-061A June 2015

Toshiaki Sato

Toshiaki Sato
General Manager
Product Development Division - 2

Montagemöglichkeiten

Montage auf 2 Seiten möglich

Seitliche Montage (Durchgangsbohrung)

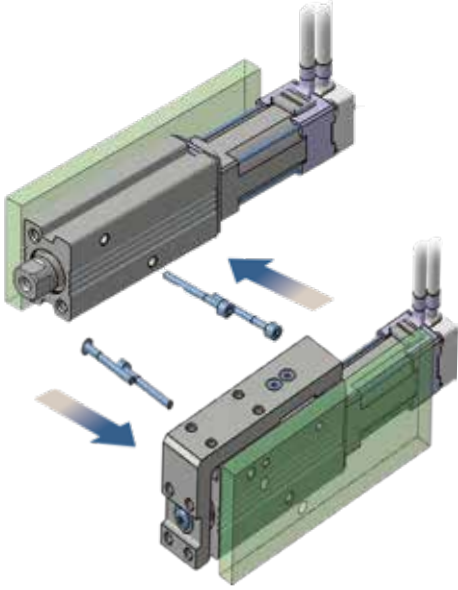

Montage von oben (Gewindebohrung)

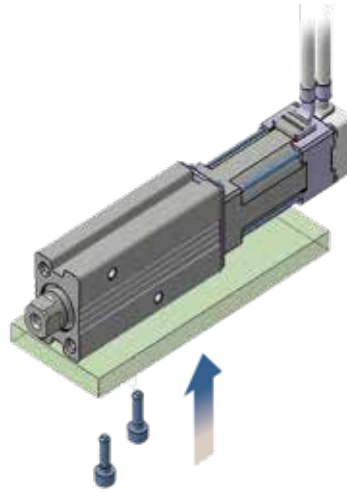

Axiale Montage nur Ausführung mit Kolbenstange (Gewindebohrung)

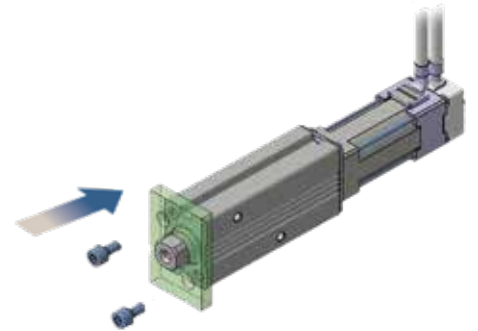

Bei der Ausführung mit Schlitten ist die Montage auf beiden Seiten möglich.

Anwendungsbeispiele

Pick-and-Place-Anwendungen

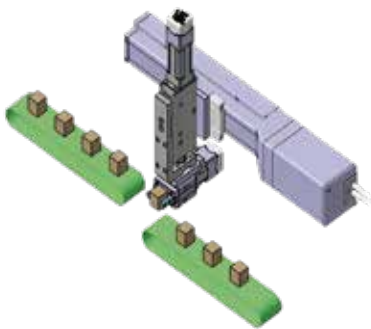

Versand

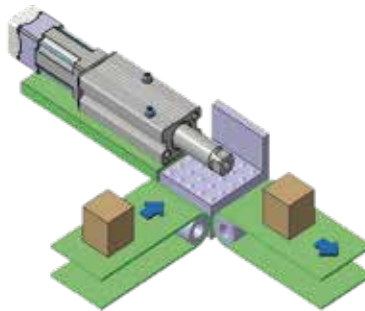

Ausrichtung

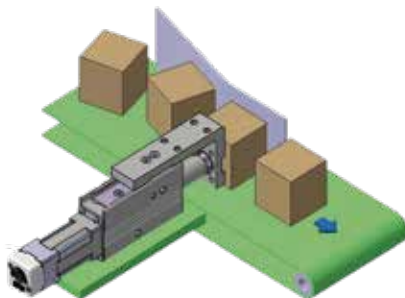

Einpressoperationen

